



NEWTON FALLS CITY COUNCIL
REGULAR MEETING AGENDA
 Wednesday, March 5, 2025; 6:00 PM
 COUNCIL CHAMBERS
 612 WEST BROAD STREET

CITY COUNCIL MEMBERS	
Ward 1	Patricia Benetis
Ward 2	Brian Axiotis
Ward 3	VACANT
Ward 4	Kevin Rufener
At- Large	Julie Stimpert
Mayor	David Hanson

CITY ADMINISTRATION	
Interim City Manager	Mike Novotny
Law Director	Jeff Limbian
Finance Director	Jamie Vernaccini
Clerk of Council	Michael Acomb

- I. Call to Order**
- II. Pledge of Allegiance / Silent Prayer**
- III. Roll Call**
- IV. Changes To Tonight's Agenda**
- V. Special Presentations by Staff Members or Invited Consultants**
- VI. Public Comments (Agenda Items Only)**
- VII. Motion to Recess into Executive Session**

MOTION

A Motion to recess into Executive Session to consider the employment and/or appointment of a public employee or official.

- VIII. Reports**
 - a. Mayor
 - b. Council Members
 - c. Law Director
 - d. Finance Director
 - e. City Manager

- IX. Approval of Previous Minutes**
 Regular Meeting Minutes February 5, 2025
 Regular Meeting Minutes February 19, 2025

- X. Public Hearings**
 ORDINANCE 2025-03 *Sponsors: Councilpersons Axiotis, Rufener*
 AN ORDINANCE REZONING THE PROPERTY AT 101 NORTH CENTER STREET
 FROM "R" RESIDENTIAL TO "C-1" COMMERCIAL, AFFIRMING THE PLANNING
 COMMISSION'S RECOMMENDATION TO REZONE THIS PROPERTY

ORDINANCE 2025-04 *Sponsors: Councilpersons Benetis, Rufener*
 AN ORDINANCE AUTHORIZING THE INTERIM CITY MANAGER TO ENTER INTO
 AN AGREEMENT TO PURCHASE AND INSTALL A REPLACEMENT INTERMEDIATE
 PUMP FROM HYDROFLO PUMPS AND NATIONAL PUMP & PROCESS INC. FOR THE
 NEWTON FALLS WATER PLANT

ORDINANCE 2025-05 *Sponsors: Councilpersons Axiotis, Stimpert*
AN ORDINANCE RECOGNIZING JACKSON STREET AREAS 44, 45, AND 46 AS
PARTS OF AN UNIMPROVED STREET, VACATING AREAS 44, 45, AND 46 OF
JACKSON STREET, AND TRANSFERRING THE VACATED SECTIONS TO THE
ADJOINING PROPERTY OWNERS

ORDINANCE 2025-06 *Sponsors: Councilpersons Axiotis, Rufener*
AN ORDINANCE AUTHORIZING THE INTERIM CITY MANAGER TO ENTER INTO
AN AGREEMENT TO AMEND THE COMPENSATION PROVISIONS OF THE
INVESTMENT MANAGEMENT AGREEMENT BETWEEN THE VILLAGE AND
MEEDER PUBLIC FUNDS, INC.

XI. Unfinished Business

ORDINANCE 2025-02 (amended) *Sponsors: Councilpersons Rufener, Stimpert*
AN ORDINANCE APPROVING THE RECODIFICATION, EDITING, AND
INCLUSION OF CERTAIN ORDINANCES AS PARTS OF THE VARIOUS CODES OF
THE CODIFIED ORDINANCES OF NEWTON FALLS, OHIO

ORDINANCE 2025-03 *Sponsors: Councilpersons Axiotis, Rufener*
AN ORDINANCE REZONING THE PROPERTY AT 101 NORTH CENTER STREET
FROM “R” RESIDENTIAL TO “C-1” COMMERCIAL, AFFIRMING THE PLANNING
COMMISSION’S RECOMMENDATION TO REZONE THIS PROPERTY

ORDINANCE 2025-04 *Sponsors: Councilpersons Benetis, Rufener*
AN ORDINANCE AUTHORIZING THE INTERIM CITY MANAGER TO ENTER INTO
AN AGREEMENT TO PURCHASE AND INSTALL A REPLACEMENT INTERMEDIATE
PUMP FROM HYDROFLO PUMPS AND NATIONAL PUMP & PROCESS INC. FOR THE
NEWTON FALLS WATER PLANT

ORDINANCE 2025-05 *Sponsors: Councilpersons Axiotis, Stimpert*
AN ORDINANCE RECOGNIZING JACKSON STREET AREAS 44, 45, AND 46 AS
PARTS OF AN UNIMPROVED STREET, VACATING AREAS 44, 45, AND 46 OF
JACKSON STREET, AND TRANSFERRING THE VACATED SECTIONS TO THE
ADJOINING PROPERTY OWNERS

ORDINANCE 2025-06 *Sponsors: Councilpersons Axiotis, Rufener*
AN ORDINANCE AUTHORIZING THE INTERIM CITY MANAGER TO ENTER INTO
AN AGREEMENT TO AMEND THE COMPENSATION PROVISIONS OF THE
INVESTMENT MANAGEMENT AGREEMENT BETWEEN THE VILLAGE AND
MEEDER PUBLIC FUNDS, INC.

XII. New Business

ORDINANCE 2025-07 *Sponsors: Councilpersons Stimpert, Rufener*
AN ORDINANCE RATIFYING AND/OR CONFIRMING THE ADMINISTRATIVE
OVERHEAD COST ALLOCATIONS TO THE ELECTRIC REVENUE FUND, THE
WATER REVENUE FUND, THE SEWER REVENUE FUND AND GENERAL FUND.

ORDINANCE 2025-08 *Sponsors: Councilpersons Stimpert, Rufener*
AN ORDINANCE AMENDING NEWTON FALLS HYDRANT BULK WATER
RATES EFFECTIVE MAY 1, 2025 FOR THE YEARS 2025 THROUGH 2026 AND
THAT THE HYDRANT WATER RATES ARE INSTITUTED WITH THE FIRE
HYDRANT USAGE METERING POLICY ATTACHED AS EXHIBIT A.

ORDINANCE 2025-09 *Sponsors: Councilpersons Stimpert, Rufener*
AN ORDINANCE AUTHORIZING THE INTERIM CITY MANAGER TO ENTER INTO
AN AGREEMENT WITH NATIONAL PUMP & PROCESS INC. TO REMOVE, REPAIR,
AND REINSTALL A HIGH SERVICE PUMP FOR THE NEWTON FALLS WATER
PLANT

ORDINANCE 2025-10 *Sponsors: Councilpersons Stimpert, Rufener*
AN ORDINANCE AUTHORIZING INTERIM CITY MANAGER TO ENTER INTO AN
AGREEMENT TO PURCHASE A 2025 FORD F-350 FROM SARCHIONE FORD
LINCOLN AND UPFITTING THE TRUCK WITH A SERVICE BODY FROM QUALITY
TRUCK BODY FOR USE BY THE WATER DISTRIBUTION DEPARTMENT

XIII. Public Comments

XIV. Closing Remarks

- a. Mayor
- b. Council Members
- c. Finance Director
- d. Law Director
- e. City Manager

XV. Adjournment



NEWTON FALLS CITY COUNCIL
REGULAR MEETING MINUTES
 Wednesday, February 5, 2025; 6:00 PM
 COUNCIL CHAMBERS
 612 WEST BROAD STREET

CITY COUNCIL MEMBERS	
Ward 1	Patricia Benetis
Ward 2	Brian Axiotis
Ward 3	VACANT
Ward 4	Kevin Rufener
At- Large	Julie Stimpert
Mayor	David Hanson

CITY ADMINISTRATION	
Interim City Manager	Mike Novotny
Law Director	Jeff Limbian
Finance Director	Jamie Vernaccini
Clerk of Council	Michael Acomb

I. Call to Order

Mayor Hanson called the meeting to order at 6:02 pm.

II. Pledge of Allegiance / Silent Prayer

III. Roll Call

Mayor Hanson asked Mr. Acomb to call the roll.

Council Present: Councilperson Axiotis, Councilperson Benetis, Councilperson Rufener, Mayor Hanson.

Council Absent: Councilperson Stimpert.

Staff Present: Interim City Manager Novotny, Clerk Acomb, Law Director Limbian.

Staff Absent: Finance Director Vernaccini.

Mr. Axiotis made a Motion to Excuse Ms. Stimpert for a family medical emergency. Seconded by Ms. Benetis.

No discussion.

Roll Call Vote: Mr. Axiotis-yes; Ms. Benetis-yes; Mr. Rufener-yes. The motion passed 3-0. Ms. Stimpert was excused.

IV. Changes To Tonight's Agenda

None.

V. Special Presentations by Staff Members or Invited Consultants

Presentation of Annual Reports

- Planning and Zoning Commission
 - Adam Zimmerman presented the annual report to Council, including meeting minutes for 8 meetings spending \$0. (Enclosed).
 - The council had no questions.
- Parks and Recreation Board
 - Not Present. No report presented. Report submitted and enclosed.

VI. Public Comments (Agenda Items Only)

None.

VII. Reports

- a. Mayor – No report.
- b. Council Members
 - i. Ward 1 – No report.

- ii. Ward 2 – He attended the Planning and Zoning Commission meeting which was adjourned to unexpected issues with the agenda items. It was rescheduled for February 11 at 6:00 pm.
- iii. Ward 4 – No report.
- c. Law Director – No report.
- d. Finance Director – She read from a prepared report (Enclosed).
- e. City Manager – He mentioned that pump issues at the water pump continues. He also received engineering information about the Church Street Substation. Information will be forthcoming.

VIII. Approval of Previous Minutes

Mayor Hanson called for a motion to approve the Regular Meeting Minutes January 22, 2025. Moved by Ms. Benetis. Seconded by Mr. Rufener.

No discussion.

Roll Call Vote: Mr. Axiotis-yes; Ms. Benetis-yes; Mr. Rufener-yes. The motion passed 3-0. The minutes were approved.

IX. Public Hearings

ORDINANCE 2025-01

Sponsors: Councilpersons Axiotis, Rufener

AN ORDINANCE AUTHORIZING THE INTERIM CITY MANAGER TO ENTER INTO AN AGREEMENT TO PURCHASE AND INSTALL A REPLACEMENT RAW WATER PUMP FOR THE WATER PLANT

None.

X. Unfinished Business

ORDINANCE 2025-01

Sponsors: Councilpersons Axiotis, Rufener

AN ORDINANCE AUTHORIZING THE INTERIM CITY MANAGER TO ENTER INTO AN AGREEMENT TO PURCHASE AND INSTALL A REPLACEMENT RAW WATER PUMP FOR THE WATER PLANT

Mayor Hanson read the ordinance by title only and asked for a motion to adopt the ordinance. Moved by Mr. Rufener. Second by Mr. Axiotis.

Mr. Rufener stated that this is the pump that Mr. Zeleny requested and has been included in the budget.

Roll Call Vote: Mr. Axiotis-yes; Ms. Benetis-yes; Mr. Rufener-yes. The motion passed 3-0. Final Reading.

XI. New Business

None.

XII. Public Comments

Nicholas Marchese. Concrete Couture.

His company performed work during the month of November. They are independent subcontractor working on concrete ramps as part of a Village asphalt project. They were not paid in full in 2024 for the project which was funded with grant money. He requested that Council hold the general contractor accountable so that his company can receive payment. He cannot afford to go to court as a small business. We wants to ensure that the wages of his workers are paid by the general contractor to his business. He clarified that his company was a sub-contractor of a sub-contractor. The general contractor claims that NF never paid them for rejection of the work by the Village. The outstanding balance is about \$7000. He stated that wage reports may have been falsified by someone. Mr. Limbian offered to lead an investigation.

John Noblock – Holland Paving. He is the sub-contractor that was not paid approximately \$90,000 by the general contractor. He contracted Concrete Couture as his sub-contractor. Some minor repairs were needed at the end of the project. The paving

was deemed unacceptable by the general contractor, but Holland never received a notice of unacceptability. He requested that Council investigate and intervene on their behalf. He admitted that he had a short timeline to submit a bid and likely did not do his due diligence with the general contractor prior to signing with them. But, requested help nonetheless because they performed the work satisfactorily and were never paid.

XIII. Closing Remarks

- a. Mayor – None.
- b. Council Members
 - i. Ward 1 – Thanks to Chief Fixler for his annual report. She made statements in support of the police department and the need to have one in Newton Falls. There was woman in need on the sidewalk and no emergency forces were called or responded. The Finance Director stated that Chief Fixler is a full-time employee and keeps normal daytime hours. She stated further that she has no information regarding citations and no revenue
 - ii. Ward 2 – The TIB meeting is on Thursday. The Planning and Zoning Commission will meet on January 11. There are vacancies on both and also for the Ward 3 seat on Council. He suggested that Mr. Marchese come to the meeting tonight. He stated belief that the Village paid their bills based on the financial records and advocated the Village no longer use the general contractor if the claims are true.
 - iii. Ward 4 – He thanked the visitors for the public comments and encouraged them to speak with the law director. The summer season is starting and Late Night in the Falls is beginning very soon. He encouraged the public to approach members of Council and to visit the businesses.
- c. Finance Director – She stated that the Village paid all invoices that were received from OHM to the primary contractor. There seem to be remaining unpaid funds; but invoices have not been received for those unpaid funds. She agreed that contractors who don't pay their subcontractors should not be permitted to do business with the Village.
- d. Law Director – None.
- e. City Manager – He received an email today; but did not know about the issue with the contractors until tonight. The Village has paid all invoices received. The bid process was done properly. He will assist with the investigation and expressed surprise that they were not paid; but the City has done their business properly, including the handling of OPWC grant money.

XIV. Motion to Recess into Executive Session (If Necessary)

Mayor Hanson called for a Motion to recess into Executive Session to consider the employment of a public employee or official.

the meeting. Moved by Mr. Axiotis. Second by Ms. Benetis.

No discussion.

Roll Call Vote: Mr. Axiotis-yes; Ms. Benetis-yes; Mr. Rufener-yes. The motion passed 3-0. Council entered executive session at 6:33 pm.

Mayor Hanson called for a Motion to exit Executive Session and to resume the regular meeting. Moved by Mr. Rufener. Second by Mr. Axiotis.

No discussion.

Roll Call Vote: Mr. Axiotis-yes; Ms. Benetis-yes; Mr. Rufener-yes. The motion passed 3-0. Council resumed regular session at 7:19 pm.

Chief Fixler was permitted to address Council. He reminded that in cases of true emergency, citizens should use 9-11 or 330-872-5757*1 to reach the County Dispatcher or 330-675-2730 to reach the Sheriff's Office. The Sheriff handles the calls for the Village and emergencies always receive a response. The Village is not currently contracted or equipped to respond to emergencies.

XV. Adjournment

Mayor Hanson called for a motion to adjourn the meeting. Moved by Mr. Rufener. Second by Ms. Benetis.

No discussion.

Roll Call Vote: Mr. Axiotis-yes; Ms. Benetis-yes; Mr. Rufener-yes. The motion passed 3-0. The meeting was adjourned at 7:21 pm.

APPROVED:

David Hanson, Mayor

ATTEST:

Michael Acomb, Clerk of Council

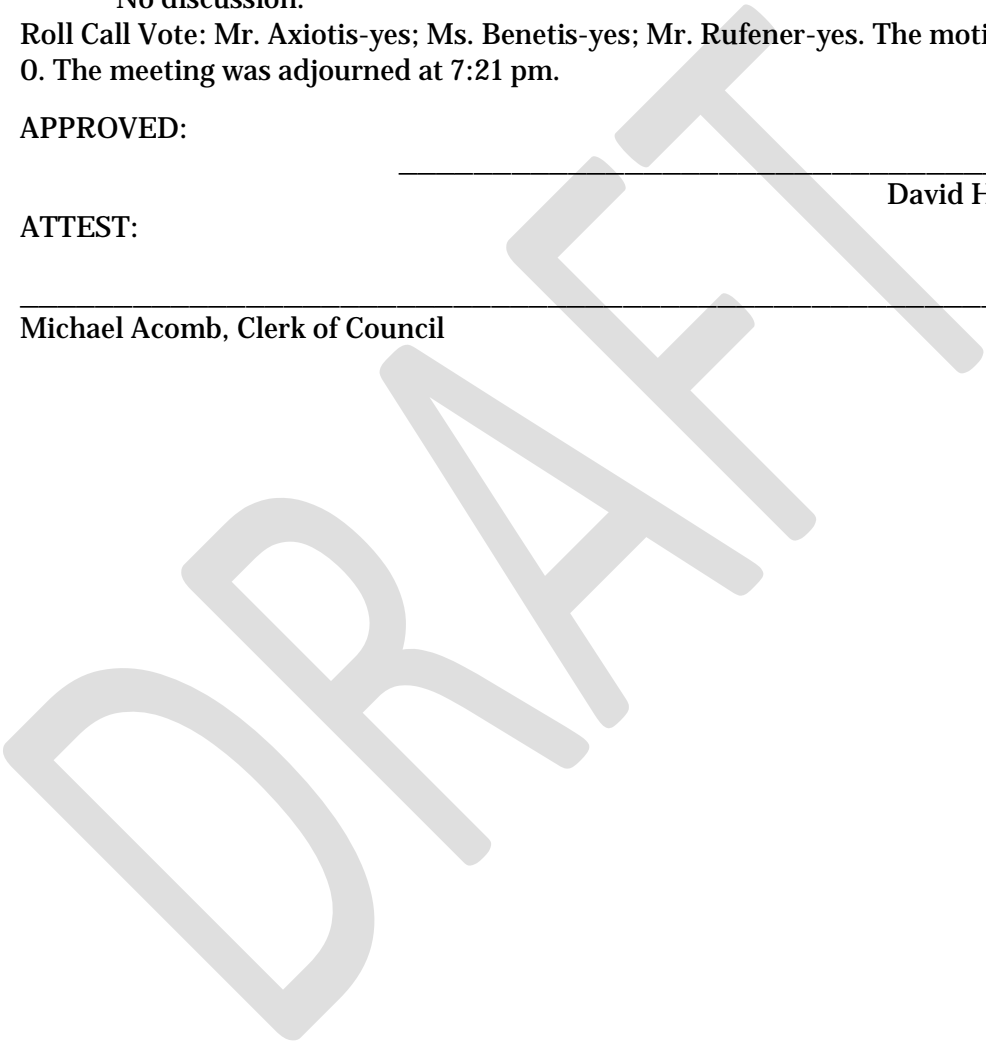

Newton Falls Planning and Zoning Commission

Year-end Report

2024

Commission Members:

- Brian Kropp – Chairman
 - Jeff Derry – Vice Chairman
 - Adam Zimmermann – Secretary
 - Condie Bright
 - Vacant Seat
-
- John Spelich – Zoning Administrator
 - Brian Axiotis – Council Representative

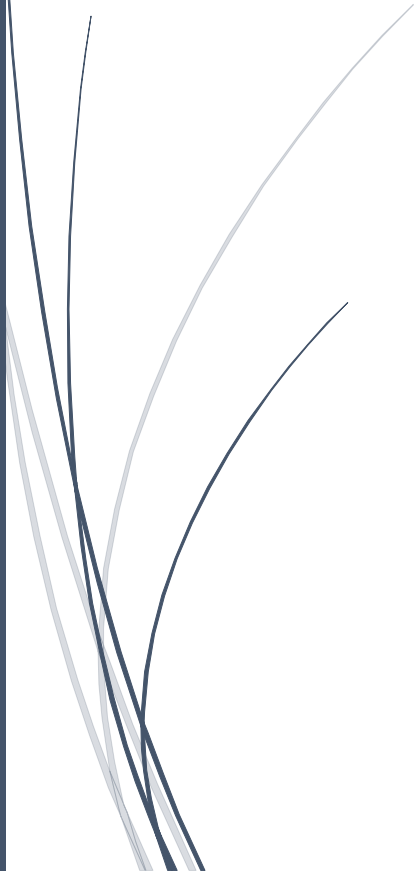

Newton Falls Planning and Zoning Commission

Year-end Report 2024

In this report you will find a summary of each of the meetings held by the Planning and Zoning Commission in 2024. The summary includes the attendance by each Commission member, any Motion that was voted on by the Commission, and any discussions held. If there are any questions on anything in this report, please contact me for clarification.

Meetings: 8

Money spent by Commission: \$0.00

Adam Zimmermann
Newton Falls Planning and Zoning Commission
Secretary
azimmermann197@gmail.com
(330) 307-6790

Newton Falls Planning and Zoning Commission

Year-end Report 2024

January 9th, 2024

1. Roll Call
 - a. Commission Members
 - i. Paul King Present
 - ii. Adam Zimmermann Present
 - iii. Jeff Derry Present
 - iv. Condie Bright Present
 - v. Denny Cottrill Present
 - b. Planning and Zoning Administrator
 - i. John Spelich Present
 - c. Council Representative
 - i. Brian Axiotis Present
2. Election of Officers
 - a. Motion to keep Paul King as Chairman and Adam Zimmermann as Secretary
 - i. Made by Jeff Derry
 - ii. Second by Condie Bright
 - b. Roll Call
 - i. Paul King Yes
 - ii. Adam Zimmermann Yes
 - iii. Jeff Derry Yes
 - iv. Condie Bright Yes
 - v. Jeff Derry Yes
 - c. Motion passed 5-0
3. Approved Motion to consolidate lots owned by Deborah Meyers (Windham and Jay Streets) to allow for the proper frontage necessary to build on the lots.
 - a. Motion made by Paul King
 - b. Seconded by Adam Zimmermann
 - i. Roll Call
 1. Paul King Yes
 2. Adam Zimmermann Yes
 3. Jeff Derry Yes
 4. Condie Bright Yes
 5. Denny Cottrill Yes
 - ii. Motion passes 5-0
4. Discussions
 - a. How can the city have cars and boats removed from public property if they are abandoned.
 - b. What can we do about bed taxes on rehab houses.
 - c. Has the fire department inspected the rehab houses?
 - d. Marijuana and Smoke Shop regulations

Newton Falls Planning and Zoning Commission

Year-end Report 2024

February 6th, 2024

Meeting called to order at 6:00 pm

Roll Call:

- Commission Members
 - Paul King Absent
 - Adam Zimmermann Present
 - Jeff Derry Present
 - Condie Bright Present
 - Denny Cottrill Present
- Zoning Administrator
 - John Spelich Present
- Council Representative
 - Brian Axiotis Present

Motion to excuse Paul King

- Motion made by Adam Zimmermann
- Second by Condie Bright
 - Roll Call
 - Adam Zimmermann Yes
 - Jeff Derry Yes
 - Condie Bright Yes
 - Denny Cottrill Yes
- Motion Passes 4-0

Discussions

- Rehab Houses
 - Will address questions with the Law Director at a later date.
- Smoke Shops
 - Will address questions with the Law Director at a later date.

Newton Falls Planning and Zoning Commission

Year-end Report 2024

March 5th, 2024

Roll Call:

- Commission Members
 - Paul King Present
 - Adam Zimmermann Present
 - Jeff Derry Present
 - Condie Bright Absent
 - Denny Cottrill Present
- Zoning Administrator
 - John Spelich Present
- Council Representative
 - Brian Axiotis Present

Discussions

- Rehab Houses
 - Open discussion with Law Director Jeff Limbian regarding what possibly could be done to limit rehab houses, restrict their locations, and the legalities involved in such actions.
- Smoke Shops
 - Open discussion with Law Director Jeff Limbian regarding what possibly could be done to limit smoke shops, restrict their locations, and the legalities involved in such actions. Discussion also included what other communities have done and what could be done in the future as far as possibly proposing legislation to Council.

Newton Falls Planning and Zoning Commission

Year-end Report 2024

April 2nd, 2024

Roll Call:

- Commission Members
 - Paul King Present
 - Adam Zimmermann Present
 - Jeff Derry Present
 - Condie Bright Absent
 - Denny Cottrill Absent
- Zoning Administrator
 - John Spelich Present
- Council Representative
 - Brian Axiotis Absent

- Motion for a variance for 5 4's Distillery to allow overnight RV camping on their commercial property for a one-time event.
 - Motion made by Adam Zimmermann
 - Second by Jeff Derry
 - Roll Call:
 - Paul King No
 - Adam Zimmermann No
 - Jeff Derry No
 - Motion failed 3-0

Public Comments/Presentation

- David McKinstry of the Newton Falls Area Commerce Association (NFACA) presented a plan to update the sign in "Kiwanis Corner" of 4 Corners Park with a Community Bulletin Board that would be installed and maintained by the NFACA. The plan was approved by the Kiwanis Club of Newton Falls. Dave McKinstry was going to pursue with John Spelich whether a zoning variance was necessary or not. If a variance was necessary, he was going to bring it back to the board for approval.

Newton Falls Planning and Zoning Commission

Year-end Report 2024

May 7th, 2024

Roll Call:

- Commission Members
 - Paul King Present
 - Adam Zimmermann Present
 - Jeff Derry Present
 - Condie Bright Absent
 - Denny Cottrill Absent
- Zoning Administrator
 - John Spelich Present
- Council Representative
 - Brian Axiotis Present

Discussions:

- Newton Falls Area Commerce Association (NFACA) sign in “Kiwanis Corner” of Four Corners Park. How is the area of sign calculated? The NFACA is being asked to apply for a variance due to the size of the total sign and sign being located within the “sight triangle” of the roads.
- Discussion on Ordinance 2024-07.
 - Passed first reading by City Council
 - Language is similar to legislation passed by Lordstown.
- Donnie Reid 5 4's Distillery
 - Wants information on the old Baryak property and what he can do with it.
 - Plans on joining Harvest Hosts which would provide free overnight RV camping on his property.
 - Also planning car shows and bike shows.
 - Also looking to add an outdoor seating area that can accommodate outdoor concerts.
 - Discussion on Commercial vs. Industrial zoning
 - Discussion on alcohol on old Baryak property
- David Carpenter – L&V Properties
 - Presented to the Commission that he wanted to subdivide 7 lots on Milton Blvd.
 - These lots would use city utilities.
 - Approval from the Commission was first step necessary before going to county to officially have the lot re-platted.
 - After discussion, a motion was made to approve the re-platting of the properties.
- Motion to approve the re-platting of the properties on Milton Blvd.
 - Motion made by Adam Zimmermann
 - Second by Paul King
 - Roll Call

Newton Falls Planning and Zoning Commission

Year-end Report 2024

- Paul King Yes
- Adam Zimmermann Yes
- Jeff Derry Yes
- Denny Cottrill Yes
- Motion Passed 4-0

Newton Falls Planning and Zoning Commission

Year-end Report 2024

July 2nd, 2024

Roll Call:

- Commission Members
 - Paul King Present
 - Adam Zimmermann Present
 - Jeff Derry Present
 - Condie Bright Present (Arrived at 6:04 pm)
 - Denny Cottrill Absent
- Zoning Administrator
 - John Spelich Present
- Council Representative
 - Brian Axiotis Present

*****Condie Bright arrived and participated in the rest of the meeting.*****

Old Business:

- NFACA/Kiwanis sign in 4 Corners Park
 - The City Manager was not sure that a variance was needed to progress with the sign installation. The old (current) sign is not located in the sight triangle of the corner. Another question arose if one variance or 3 variances might be necessary if new sign is significantly moved due to being 3 panels and not just one pane. The sign is ordered and scheduled to be delivered July 18 – 27.

New Business:

- A discussion regarding reverting Clonch properties from Residential back to Commercial that were changed to commercial on the last Zoning Map.
 - The discussion started by noting that the Comprehensive Plan was put together to evaluate plans for the future. Discussion on how the plan came into effect and what was done in the past. Roy Clonch was advised to make a variance request for every property that he would like reverted to Commercial. He was advised to go through the Zoning Inspector with his variance requests and then they would be presented to the Planning and Zoning Commission for review. The properties discussed were: 35 Vine St., 55 East Jay St., 49 Jay St., and 43 Jay St.

Discussions:

- Township Resident and Business Owner Tom Colosimo brought up DORA (Designated Outdoor Refreshment Area) and how it would benefit the downtown businesses. He would like to see this presented back to council. Discussion on how this would benefit the businesses in our downtown shopping district. It was mentioned that we had 4 businesses downtown that sell alcohol and could benefit from this. Discussion on how the City of Warren is currently limiting their DORA to special weekends with a police presence.

Newton Falls Planning and Zoning Commission

Year-end Report 2024

- Discussion on the price of food truck registration. The pricing of the registration was discussed with how this is limiting the amount of food trucks that come into our town. Also discussed how this might be affecting the businesses that are bringing in the food trucks that are paying for their registration for the food trucks. Discussion to continue at the next meeting.

Newton Falls Planning and Zoning Commission

Year-end Report 2024

September 3rd, 2024

Roll Call:

- Commission Members
 - Paul King Present
 - Adam Zimmermann Present
 - Jeff Derry Absent (At time of roll call; arrived 6:07 pm)
 - Condie Bright Present
- Zoning Administrator
 - John Spelich Present
- Council Representative
 - Brian Axiotis Present

*****Jeff Derry arrived and participated in the rest of the meeting.*****

Old Business:

- Food Truck Pricing
 - Discussion ensued on the current pricing of food truck permits and whether a motion should be made to have City Council make a motion to adjust the price of the permits.
 - Pros and cons of adjusting the permit price
 - Would a seasonal pass (summer months) be appropriate?
 - Would adjusting the price of the permit hurt or help businesses?
 - Would adjusting the price of the permit be beneficial to the city?
 - No action was taken at this time

Newton Falls Planning and Zoning Commission

Year-end Report 2024

October 1st, 2024

Roll Call:

- Commission Members
 - Paul King Present
 - Adam Zimmermann Present
 - Jeff Derry Present
 - Condie Bright Absent
- Zoning Administrator
 - John Spelich Present
- Council Representative
 - Brian Axiotis Present

New Business:

- Request to revert Jerry Daniel property (101 N. Center St.) from Residential to Commercial.
 - Jerry Daniel: 712 Beaver St., Girard, OH addressed the Commission.
 - Discussion was had on Jerry Daniel not knowing when property was changed from Commercial to Residential zoning. No one had the answer to that at the time of Commission meeting.
 - Jerry has the deed to the property, but it doesn't list how it was zoned.
 - Discussion ensued on what could be done that night to have the property rezoned. It was stated that the Commission did not have the authorization to rezone property on its own and that belonged with City Council.
 - It was recommended that Jerry Daniel put in a formal request in writing to the Zoning Administrator to start moving forward on this issue
 - Roy Clonch also addressed the commission at this time on what it would take to have his properties rezoned from Residential back to Commercial.
 - He stated that there was no notification given at the time of the rezoning on the status change to his property.
 - It was also stated to him that the Commission did not have the authority to rezone property and that belonged with City Council.
 - It was also recommended that he put a formal request in writing to the Zoning Administrator to start moving forward on this issue.
 - No formal action was taken by the Commission at this time.

- David McKinstry (NFACA) to present Maintenance Agreement between Newton Falls Area Commerce Association (NFACA) and the Kiwanis Club of Newton Falls for sign in Four Corners Park.
 - David McKinstry was not present to present the Maintenance Agreement to the Commission.

Newton Falls Planning and Zoning Commission

Year-end Report 2024

- An email from the Law Director was presented to the Commission stating that he had no issues with the agreement.
- The Maintenance Agreement was determined not to be a zoning issue that needed to be addressed by the Commission.
- No action was taken on the Maintenance Agreement.

- Motion to accept the combining of lots 255, 256, & 257 in Rose Park Allotment into one parcel.
 - Discussion was had on what happened once the Commission approved the motion. It was explained that it then went to the county for final approval.
 - Paul King stated that he had no issues with combining the lots.
 - Adam Zimmermann also stated that he saw no issues with this.
 - Motion made by Paul King
 - Second by Jeff Derry
 - Roll Call
 - Paul King Yes
 - Adam Zimmermann Yes
 - Jeff Derry Yes
 - Motion Passes 3-0

Parks and Recreation Committee Annual Report 2024

Committee members: Laura Neiheisel, chair; Heidi Zimmermann, secretary; John Donato
Council Representative: Brenda Persino

The focus of the committee in 2024 was on upkeep of the city's playgrounds.

Accomplishments in this area included

1. Installation of one ADA swing at the pavilion play area.
2. New mulch at every city playground.
3. Fresh paint and artwork at the skate park.

All P&R projects continue to be funded out of the city's budget allocation with the approval of council and/or the city manager. All financial information can be found on the city website.

This committee believes that the ongoing needs of the playgrounds and parks far surpass the budget provided, and we suggest that council and CM consider consulting with a grant writer who has the ability and knowledge to pursue and procure any matching funds available.

P&R would like to thank the school administration, students, and citizen volunteers for all their hard work on removing the graffiti and updating the skate park.

We also wish to thank the CM and Council for their cooperation and especially Council Rep Brenda Persino for her dedication, enthusiasm and many hours of behind the scenes work for the committee.



Finance Directors Report

To: Members of Council
David Hanson, Mayor
Mike Novotny, City Manager
Jeff Limbian, Law Director

From: Jamie Vernaccini, Director of Finance

Date: February 5, 2025

Subject: Finance Department

I would like to personally thank the Electric and the Water Departments. These departments pushed through extra work installing the remaining new utility meters on a tight schedule. The Finance Department can now begin the conversion of the accounting software from EGOV to VIP as these meters are now communicating with the EGOV system.

January Month End:

The Finance Office successfully closed out the month of January without any significant reconciling issues. The EGOV system now reflects the appropriations adopted by Council in the Fall

TIB:

The TIB Quarterly meeting is next week. The TIB is still missing one community member if anyone is interested in filling this position please contact the Finance Director or Brian Axiotis for more information.



NEWTON FALLS CITY COUNCIL
REGULAR MEETING AGENDA
 Wednesday, February 19, 2025; 6:00 PM
 COUNCIL CHAMBERS
 612 WEST BROAD STREET

CITY COUNCIL MEMBERS	
Ward 1	Patricia Benetis
Ward 2	Brian Axiotis
Ward 3	VACANT
Ward 4	Kevin Rufener
At- Large	Julie Stimpert
Mayor	David Hanson

CITY ADMINISTRATION	
Interim City Manager	Mike Novotny
Law Director	Jeff Limbian
Finance Director	Jamie Vernaccini
Clerk of Council	Michael Acomb

- I. Call to Order**
 Mayor Hanson called the meeting to order at 6:06 pm.
- II. Pledge of Allegiance / Silent Prayer**
- III. Roll Call**
 Mayor Hanson asked Mr. Acomb to call the roll.
 Council Present: Councilperson Axiotis, Councilperson Benetis, Councilperson Stimpert, Mayor Hanson.
 Council Absent: Councilperson Rufener.
 Staff Present: Interim City Manager Novotny, Clerk Acomb, Law Director Limbian.
 Staff Absent: Finance Director Vernaccini.
- IV. Changes To Tonight's Agenda**
 Mr. Axiotis made a Motion to Excuse Mr. Rufener for personal illness. Seconded by Ms. Stimpert.
 No discussion.
 Roll Call Vote: Mr. Axiotis-yes; Ms. Benetis-yes; Ms. Stimpert-yes. The motion passed 3-0. Mr. Rufener was excused.
- V. Special Presentations by Staff Members or Invited Consultants**
 None.
- VI. Public Comments (Agenda Items Only)**
 None.
- VII. Reports**
 - a. Mayor - No report.
 - b. Council Members
 - i. Ward 2 – He attended the Planning and Zoning Commission Meeting this past week in which much discussion of zoning changes occurred. Some of that discussion appears on tonight's agenda and there will be more to come. There are now two vacancies on the Planning and Zoning Commission, one vacancy on the Parks and Recreation Board and one vacancy for a resident on the Treasury Investment Board. He urged residents to fill these vacancies as it is impossible to accomplish anything without a quorum.
 - c. Law Director – No report.
 - d. Finance Director – She read from prepared report (Enclosed).

- e. City Manager – He read from prepared report (Enclosed). He also presented a quote and recommended that Ordinance 2025-04 be amended tonight to include this quote as an exhibit and to revise the dollar amount in the ordinance. The new quote, just received, is for the demolition and removal of the old intermediate pump.

VIII. Approval of Previous Minutes

Mayor Hanson called for a motion to approve the Regular Meeting Minutes February 5, 2025. Ms. Stimpert announced that she was absent from this meeting and intended to abstain. Mr. Axiotis made a motion to table this motion until the next regular meeting. Seconded by Ms. Benetis.

No discussion.

Roll Call Vote: Mr. Axiotis-yes; Ms. Benetis-yes; Ms. Stimpert-yes. The motion passed 3-0.

IX. Public Hearings

None.

X. Unfinished Business

None.

XI. New Business

RESOLUTION 01-2025

Sponsors: Councilpersons Benetis, Rufener

A RESOLUTION REVISING THE METHODOLOGY USED TO DETERMINE ADMINISTRATIVE OVERHEAD COST ALLOCATIONS IN ORDER TO ASSIGN THE SHARED COST OF AN ITEM OR SERVICE TO THE GENERAL FUND, THE WATER REVENUE FUND, THE SEWER REVENUE FUND AND THE ELECTRIC REVENUE FUND OF VILLAGE OF NEWTON FALLS TO ENSURE THAT COSTS ARE SHARED EQUITABLY ACROSS THESE FUNDING SOURCES.

Mayor Hanson read the resolution by title only and asked for a motion to adopt the resolution. Moved by Mr. Axiotis. Second by Ms. Benetis.

Mr. Axiotis asked the finance director to explain. She explained that allocations are approved by the Council and this methodology provides for the administrative costs of the City to be divided equitably among the various departments. The current methodology includes previous year's appropriations as a factor in making the determinations. Due to the Scott Street Project, the methodology skews the amount of expenditure that is attributed to the sewer fund. This new methodology will remove appropriations from the calculations but still maintains equity and fairness to all departments.

Roll Call Vote: Mr. Axiotis-yes; Ms. Benetis-yes; Ms. Stimpert-yes. The motion passed 3-0.

ORDINANCE 2025-02

Sponsors: Councilpersons Rufener, Stimpert

AN EMERGENCY ORDINANCE APPROVING THE RECODIFICATION, EDITING, AND INCLUSION OF CERTAIN ORDINANCES AS PARTS OF THE VARIOUS CODES OF THE CODIFIED ORDINANCES OF NEWTON FALLS, OHIO

Mayor Hanson read the ordinance by title only and asked for a motion to adopt the ordinance. Moved by Ms. Stimpert. Second by Ms. Benetis.

No discussion.

Roll Call Vote: Mr. Axiotis-yes; Ms. Benetis-yes; Ms. Stimpert-yes. The motion passed 3-0. First Reading.

Mayor Hanson read the ordinance by title only and asked for a motion to adopt the ordinance. Moved by Ms. Stimpert. Second by Ms. Benetis.

No discussion.

Roll Call Vote: Mr. Axiotis-yes; Ms. Benetis-yes; Ms. Stimpert-yes. The motion passed 3-0. Final Reading.

NOTE: Ordinance 2025-02 was read as an emergency ordinance. As an emergency, the Charter requires 4 affirmative votes of Council when there is a vacancy on the Council. The Ward 3 seat is Vacant. Also,

with only the presence of 3 members of Council tonight, the ordinance was unable to receive the required 4 affirmative votes. Therefore, despite having received two readings tonight, it must start the adoption process from the beginning. It will appear on the regular meeting agenda of March 5, 2025 in Unfinished Business. It will receive a public hearing and final reading on March 19. Mr. Limbian was consulted and has recommended this course of action.

ORDINANCE 2025-03

Sponsors: Councilpersons Axiotis, Rufener

AN ORDINANCE REZONING THE PROPERTY AT 101 NORTH CENTER STREET FROM “R” RESIDENTIAL TO “C-1” COMMERCIAL, AFFIRMING THE PLANNING COMMISSION’S RECOMMENDATION TO REZONE THIS PROPERTY

Mayor Hanson read the ordinance by title only and asked for a motion to adopt the ordinance. Moved by Mr. Axiotis. Second by Ms. Stimpert.

Mr. Axiotis stated the Planning and Zoning Commission has been reviewing this issue for some time. A surveyor’s office has been at this property for many years and needs to be zoned appropriately. At one point the property was rezoned residential and that has been challenged as the owner is trying to sell the property. The Commission is recommending that all fees be waived unanswered questions regarding the proper procedures when it was rezoned to residential.

Roll Call Vote: Mr. Axiotis-yes; Ms. Benetis-yes; Ms. Stimpert-yes. The motion passed 3-0. First Reading.

ORDINANCE 2025-04

Sponsors: Councilpersons Benetis, Rufener

AN ORDINANCE AUTHORIZING THE INTERIM CITY MANAGER TO ENTER INTO AN AGREEMENT TO PURCHASE AND INSTALL A REPLACEMENT INTERMEDIATE PUMP FROM HYDROFLO PUMPS AND NATIONAL PUMP & PROCESS INC. FOR THE NEWTON FALLS WATER PLANT

Mayor Hanson read the ordinance by title only and asked for a motion to adopt the ordinance. Moved by Mr. Axiotis. Seconded by Ms. Benetis.

Mr. Axiotis corrected an error in the Interim City Manager’s report. He then made a motion to amend the ordinance to change the value of the purchases from \$24,662 to \$45,759 and to include the provided quotes as Exhibit B.

Roll Call Vote: Mr. Axiotis-yes; Ms. Benetis-yes; Ms. Stimpert-yes. The motion passed 3-0. The ordinance was amended.

Ms. Stimpert made a motion to adopt the ordinance as amended. Seconded by Ms. Benetis.

No discussion.

Roll Call Vote: Mr. Axiotis-yes; Ms. Benetis-yes; Ms. Stimpert-yes. The motion passed 3-0. The ordinance was adopted as amended. First Reading.

ORDINANCE 2025-05

Sponsors: Councilpersons Axiotis, Stimpert

AN ORDINANCE RECOGNIZING JACKSON STREET AREAS 44, 45, AND 46 AS PARTS OF AN UNIMPROVED STREET, VACATING AREAS 44, 45, AND 46 OF JACKSON STREET, AND TRANSFERRING THE VACATED SECTIONS TO THE ADJOINING PROPERTY OWNERS

Mayor Hanson read the ordinance by title only and asked for a motion to adopt the ordinance. Moved by Mr. Axiotis. Seconded by Ms. Benetis.

Mr. Axiotis stated Jackson Street is a paper street and the Village has no intention to use it as a road. He explained that the adjacent property owners expressed interest in taking on a portion of the property and this allows them to take ownership of their respective adjacent parcels.

Roll Call Vote: Mr. Axiotis-yes; Ms. Benetis-yes; Ms. Stimpert-yes. The motion passed 3-0. First Reading.

ORDINANCE 2025-06

Sponsors: Councilpersons Axiotis, Rufener

AN ORDINANCE AUTHORIZING THE INTERIM CITY MANAGER TO ENTER INTO AN AGREEMENT TO AMEND THE COMPENSATION PROVISIONS OF THE INVESTMENT MANAGEMENT AGREEMENT BETWEEN THE VILLAGE AND MEEDER PUBLIC FUNDS, INC. Mayor Hanson read the ordinance by title only and asked for a motion to adopt the ordinance. Moved by Mr. Axiotis. Seconded by Ms. Benetis.

Mr. Axiotis stated that this was discussed at the Treasury Investment Board meeting. Meeder changed their fee structure from \$5000 to \$7500 annually. The Village wishes to continue the partnership with Meeder.

Roll Call Vote: Mr. Axiotis-yes; Ms. Benetis-yes; Ms. Stimpert-yes. The motion passed 3-0. First Reading.

XII. Public Comments

None.

XIII. Closing Remarks

- a. Mayor – No remarks.
- b. Council Members
 - i. Ward 2 – He reiterated the vacancies on each of the committees.
 - ii. At-Large – She stated that the vacancies on each of the committees need to be filled or the committees will not be able to operate.
- c. Finance Director – No remarks.
- d. Law Director – No remarks.
- e. City Manager – No remarks.

XIV. Motion to Recess into Executive Session (If Necessary)

Mayor Hanson called for a Motion to recess into Executive Session to consider the employment of a public employee or official. Moved by Mr. Axiotis. Second by Ms. Stimpert.

No discussion.

Roll Call Vote: Mr. Axiotis-yes; Ms. Benetis-yes; Ms. Stimpert-yes. The motion passed 3-0. Council entered executive session at 6:31 pm.

Mayor Hanson called for a Motion to exit Executive Session and to resume the regular meeting. Moved by Mr. ---. Second by Mr. ---.

No discussion.

Roll Call Vote: Mr. Axiotis-yes; Ms. Benetis-yes; Ms. Stimpert-yes. The motion passed 3-0. Council resumed regular session at --- pm.

XV. Adjournment

Mayor Hanson called for a motion to adjourn the meeting. Moved by Mr. ---. Second by Ms. ---.

No discussion.

Roll Call Vote: Mr. Axiotis-yes; Ms. Benetis-yes; Ms. Stimpert-yes. The motion passed 3-0. The meeting was adjourned at --- pm.

APPROVED:

David Hanson, Mayor

ATTEST:

Michael Acomb, Clerk of Council

DRAFT

VILLAGE OF NEWTON FALLS, OHIO
ORDINANCE NO.: 2025-02 (amended)
SPONSORS: Councilpersons Rufener, Stimpert

**AN ORDINANCE APPROVING THE RECODIFICATION, EDITING, AND
INCLUSION OF CERTAIN ORDINANCES AS PARTS OF THE VARIOUS CODES OF
THE CODIFIED ORDINANCES OF NEWTON FALLS, OHIO**

WHEREAS, various ordinances of a general and permanent nature have been passed which should be included in the Codified Ordinances of Newton Falls, Ohio; and

WHEREAS, Council desires to amend the Village Codified Ordinances accordingly.

NOW, THEREFORE, the Council of the Village of Newton Falls, State of Ohio, hereby ordains:

SECTION 1: That the editing, arrangement and numbering of those ordinances and resolutions enacted by Council from December 1, 2023 to December 1, 2024, are hereby approved and adopted as printed in the 2024 Replacement Pages to the Codified Ordinances so as to achieve uniformity of style and classification. A copy of such replacement pages are attached to this ordinance and incorporated as a part hereof.

SECTION 2: That the following sections of the Traffic, General Offenses, and Building Codes, as amended, are hereby approved and adopted as amended or enacted so as to conform to enactments of the Ohio General Assembly:

Traffic Code

- 301.35 School Bus. (Amended)
- 303.01 Compliance with Lawful Order of Police Officer; Fleeing. (Amended)
- 303.083 Impounding Vehicles on Public Property. (Amended)
- 303.10 Leaving Junk Vehicles on Private Property with Permission of Owner. (Amended)
- 303.991 Committing an Offense While Distracted Penalty. (Amended)
- 331.38 Stopping for School Bus; Discharging Children. (Amended)
- 331.46 Restrictions on the Operation of School Buses. (Added)
- 333.03 Maximum Speed Limits; Assured Clear Distance Ahead. (Amended)
- 333.07 Street Racing, Stunt Driving and Street Takeovers Prohibited. (Amended)
- 333.11 Electronic Wireless Communication Device Use Prohibited While Driving. (Amended)
- 337.16 Number of Lights; Limitations on Flashing, Oscillating or Rotating Lights. (Amended)
- 337.26 Child Restraint System Usage. (Amended)
- 337.32 Lights and Sign on Transportation for Preschool Children. (Added)
- 341.04 Commercial Drivers Prohibitions. (Amended)
- 341.05 Criminal Offenses. (Amended)
- 351.04 Parking Near Curb; Handicapped Locations on Public and Private Lots and Garages. (Amended)

General Offenses Code

- 501.01 General Provisions and Penalty Definitions. (Amended)
- 505.19 Rights of Blind, Deaf or Hearing Impaired, or Mobility Impaired Person, or Trainer with Assistance Dog. (Added)
- 509.06 Inducing Panic. (Amended)
- 509.10 Impeding Public Passage of an Emergency Service Responder. (Added)
- 513.01 Drug Abuse Control Definitions. (Amended)
- 513.02 Gift of Marihuana. (Amended)
- 513.16 Adult Use Cannabis Control; Limitations on Conduct by Individuals. (Added)
- 529.07 Open Container Prohibited. (Amended)
- 533.03 Unlawful Sexual Conduct with a Minor. (Amended)
- 533.04 Sexual Imposition. (Amended)
- 533.08 Procuring; Engagement in Sexual Activity for Hire. (Amended)
- 537.02 Vehicular Homicide and Manslaughter. (Amended)
- 537.021 Vehicular Assault in a Construction Zone. (Amended)
- 537.03 Assault. (Amended)
- 537.12 Misuse of 9-1-1 System. (Amended)
- 537.16 Illegal Distribution of Cigarettes, Other Tobacco Products, or Alternative Nicotine Products; Transaction Scans. (Amended)
- 549.10 Possessing Replica Firearm in School. (Amended)
- 549.12 Concealed Handgun Licenses; Possession of Revoked or Suspended License; Additional Restrictions; Posting Signs Prohibiting Possession.

SECTION 3: That all formal action of this Council concerning and relating to the adoption of this Ordinance was taken in an open meeting of this Council, and all deliberations of this Council or any of its committees that resulted in such formal action were taken in meetings open to the public and/or in compliance with all legal requirements, including Section 121.22 of the Ohio Revised Code.

PASSED IN COUNCIL THIS _____ DAY OF MARCH, 2025.

David Hanson, Mayor

Attest:

Michael Acomb, Clerk of Council

Approved as to Legal Form.

Jeff Limbian, Law Director

VILLAGE OF NEWTON FALLS, OHIO

ORDINANCE NO.: 2025-02

SPONSORS: Councilpersons Benetis, Stimpert

**AN EMERGENCY ORDINANCE APPROVING THE RECODIFICATION,
EDITING, AND INCLUSION OF CERTAIN ORDINANCES AS PARTS OF THE
VARIOUS CODES OF THE CODIFIED ORDINANCES OF NEWTON FALLS, OHIO**

Link to the Exhibit for Ordinance 2025-02 – [Click here to download](#)

VILLAGE OF NEWTON FALLS, OHIO
ORDINANCE NO.: 2025-03
SPONSOR: Councilpersons Axiotis, Rufener

AN ORDINANCE REZONING THE PROPERTY AT 101 NORTH CENTER STREET FROM “R” RESIDENTIAL TO “C-1” COMMERCIAL, AFFIRMING THE PLANNING COMMISSION’S RECOMMENDATION TO REZONE THIS PROPERTY

WHEREAS, on January 7, 2025, the Village Planning Commission voted to recommend the rezoning of the property at 101 North Center Street based on the owner’s application to rezone the property from “R” Residential to “C” Commercial.

NOW, THEREFORE, the Council of the Village of Newton Falls, State of Ohio, hereby ordains:

SECTION 1. That Council hereby rezones the property at 101 North Center Street from “R” to “C-1” based on the Planning Commission’s recommendation to grant the change based on the application to rezone the property, finding that the amendment is warranted due to changes of an economic, physical, or social nature within the area involved which were not anticipated by the comprehensive plan and which have substantially altered the basic characteristics of the area.

SECTION 2. That Council hereby and herein approves the recommendation of the Planning and Zoning Commission to waive the rezoning fee of \$200 typically payable by the property owner.

SECTION 3. That all formal actions of this Council concerning and relating to the adoption of this Ordinance were taken in an open meeting of this Council, and all deliberations of this Council or any of its committees that resulted in such formal action were taken in meetings open to the public and/or in compliance with all legal requirements, including Section 121.22 of the Ohio Revised Code.

SECTION 4. That this Ordinance shall be effective as of the earliest date permitted by law.

PASSED IN COUNCIL THIS _____ DAY OF _____, 2025

David Hanson, Mayor

Attest:

Michael Acomb, Clerk of Council

Approved as to Legal Form.

Jeff Limbian, Law Director

VILLAGE OF NEWTON FALLS, OHIO
ORDINANCE NO.: 2025-04 (amended)
SPONSOR: Councilpersons Axiotis, Rufener

AN ORDINANCE AUTHORIZING THE INTERIM CITY MANAGER TO ENTER INTO AN AGREEMENT TO PURCHASE AND INSTALL A REPLACEMENT INTERMEDIATE PUMP FROM HYDROFLO PUMPS AND NATIONAL PUMP & PROCESS INC. FOR THE NEWTON FALLS WATER PLANT

WHEREAS, the existing intermediate pump at the Water Plant has failed and no longer operates properly; and

WHEREAS, the Water Department Superintendent and Interim City Manager investigated and received options for the purchase and installation services of a replacement pump, as well as the removal and disposal services for the existing pump; and

WHEREAS, pursuant to Ohio Revised Code Section 9.17, formal advertisement and bidding are not required as the purchase is less than \$75,000; and

WHEREAS, Village Council desires to accept the quotation (Exhibit A) from Hydroflo Pumps and National Pump & Process Inc. located at 180 Treat Road, Aurora, OH 44202., for the purchase and installation services of a replacement pump, as well as the removal and disposal services for the existing pump, as it was determined by the Interim City Manager to be the most cost-effective corrective measure and the lowest and best price for the project; and

WHEREAS, adequate funds for such a request are available for use in 2025.

NOW, THEREFORE, the Council of the Village of Newton Falls, State of Ohio, hereby ordains:

SECTION 1. That Council hereby and herein authorizes the Interim City Manager to enter into an agreement with Hydroflo Pumps and National Pump & Process Inc. located at 180 Treat Road, Aurora, OH 44202, to purchase a replacement intermediate pump and to contract with said company for installation services and removal/disposal services of the existing pump for \$45,759.00 as set forth in the attached quotations (Exhibits A and B).

SECTION 2. That all formal action of this Council concerning and relating to the adoption of this Ordinance was taken in an open meeting of this Council, and all deliberations of this Council or any of its committees that resulted in such formal action were taken in meetings open to the public and/or in compliance with all legal requirements, including Section 121.22 of the Ohio Revised Code.

SECTION 3. That this Ordinance shall be effective as of the earliest date permitted by law.

ORDINANCE NO.: 2025-04
PAGE 2

PASSED IN COUNCIL THIS _____ DAY OF _____, 2025.

David Hanson, Mayor

Attest:

Michael Acomb, Clerk of Council

Approved as to Legal Form.

Jeff Limbian, Law Director



QUOTATION

Date: February 10, 2025

ZERO LEAD PUMPS®

Quote #: 2502006

Project: Newton Falls WTP

Job #: Intermediate Pump

Page #: 1 of 10

Attention: *CODY ZELENY*

E-Mail: *Waterplant@ci.newtonfalls.oh.us*

Phone: *330-719-2175*

Fax:

Company: *Newton Falls WTP*

Address: *175 W. River Rd*

City, State: *Newton Falls OH*

From: *MATT GLOVA*

E-Mail: *National Pump & Process*

Phone: *matt@nationalpump.com*

Fax: *216-316-3097*

Address: *180 Treat Rd*

City, State: *Aurora, OH 44202*

Qty	Part #	Description	Unit Price	Total
		* DESIGN: 1102 USGPM @ 40.1' TDH, 1770 RPM, * 75% Efficient, 14.9 BHP, 172.27 Inch TPL (+/- 1.5")		
1	9ZC2C-58401-w_B0	9ZC - 2 Stage W/L VERTICAL TURBINE PUMP ASSEMBLY *** Fully Assembled Vertical Turbine *** DRIVER ASSEMBLY SECTION <ul style="list-style-type: none"> • US 20HP, 1800RPM, 3PH/60Hz/230-460V, Premium Efficient, 256TPH Frame VHS-WP1 w/ NRR and 1.1875" Drive Coupling – Motor Type: AUS – Motor CD = 23.38" DISCHARGE HEAD ASSEMBLY SECTION <ul style="list-style-type: none"> • 1.1875" x 29.38" x 416SS Head Shaft Assembly w/ 12TPI-LH Bronze Adjusting Nut and Key • F-Style Fabricated Steel Head with 8" 150# RF Discharge Flange for 12" BD with 19" W x 19" L x 1.25" Thick Integral Base – Shaft Guard: Special Fabrication – 1.1875" Cast Iron Packing Box Assembly w/ B10 C932 Bronze Bearing, John Crane #1345 Packing, Bronze Lantern Ring and SS Packing Gland • Base Plate: Standard Steel HF8 24.0" W x 24.0" L x 1.0" Thick COLUMN ASSEMBLY SECTION <ul style="list-style-type: none"> • 3 Piece Column Assembly: ~ 140.75" of 8" x .322" Wall x 4' 11-1/4" Steel Water Lubricated Column with Threaded Couplings • 2 Pc(s): 8" x 2" x .75" Spiders w/ Rubber Inserts • 3 Piece Lineshaft Assembly: 1.1875" -WL 12 TPI x 60" x 416SS w/ 416SS Couplings – Top Shaft: 1.1875" -WL 12 TPI x 416SS w/ 416SS Coupling – Lineshaft: 1.1875" -WL 12 TPI x 416SS w/ 416SS Couplings BOWL ASSEMBLY SECTION <ul style="list-style-type: none"> • 9ZC - 2 Stage Product Lubricated Bowl Assembly w/ 18-8 SS Fasteners including: <ul style="list-style-type: none"> – 8" Butt Thread, Ductile Iron Discharge Case with B10 C932 Bronze Bearing – Ductile Iron Bowls – B10 C932 Bronze Bowl Bearings – 201SS Impellers with 316SS Collets – 416SS Bowl Shaft: 8.00" Water Lube Projection x 1.1875" DIA - WL 12 TPI – 8" NPT, Ductile Iron Suction Case with B10 C932 Bronze Bearing * Special Bowl Notes: <ul style="list-style-type: none"> – NO STRAINER PER CUSTOMER REQUEST. • Crating and Painting • Min. Submergence from Bottom of Suction for Vortex Suppression = 33" (In.). **This does not include NPSHr requirements. NPSHr at Duty Point = 13.6' (Ft.) • Estimated Total Assembly Weight As Above: 2323 Lbs. • Standard time to have ready to ship is ~ 12 to 14 weeks A.R.O. based on current inventory and factory loads. 	\$ 24,662.00	\$ 24,662.00

Shipment time is an approximation based on current inventory and factory production schedules. Quotation is valid for 30 days from Quote date.

Company: Newton Falls WTP
 Date: 2/10/2025



Pump:

Size: 9ZC (2 stage)
 Type: Vertical
 Synch Speed: 1800 rpm
 Curve: 010311
 Specific Speeds:
 Dimensions:
 Vertical Turbine:

Speed: 1770 rpm
 Dia: 7.46 in
 Impeller: 9ZC SS ENCL.
 Ns: ---
 Nss: ---
 Suction: 8 in
 Discharge: 8 in
 Bowl Size: 9.5 in
 Max Lateral: 0.5 in
 Thrust K Factor: 13.6 lbf/ft

Search Criteria:

Flow: 1100 US gpm Head: 40 ft

Fluid:

Water
 Density: 62.32 lb/ft³
 Viscosity: 0.9946 cP
 NPSHa: ---

Temperature: 68 °F
 Vapor Pressure: 0.3391 psi a
 Atm Pressure: 14.7 psi a

Motor:

Standard: NEMA
 Enclosure: WP1
 Sizing Criteria: Max Power on Design Curve

Size: 20 hp
 Speed: 1800 rpm
 Frame: 256T

Pump Limits:

Temperature: 140 °F
 Pressure: 300 psi g
 Sphere Size: 1.44 in

Power: 270 hp
 Eye Area: 26.7 in²

---- Duty Point ----	
Flow:	1102 US gpm
Head:	40.1 ft
Eff:	75%
Power:	14.9 hp
NPSHr:	13.6 ft
---- Design Curve ----	
Shutoff Head:	79.1 ft
Shutoff dP:	34.2 psi
Min Flow:	231 US gpm
BEP:	75.3% @ 1155 US gpm
NOL Power:	19.6 hp @ 400 US gpm
-- Max Curve --	
Max Power:	33.5 hp @ 400 US gpm

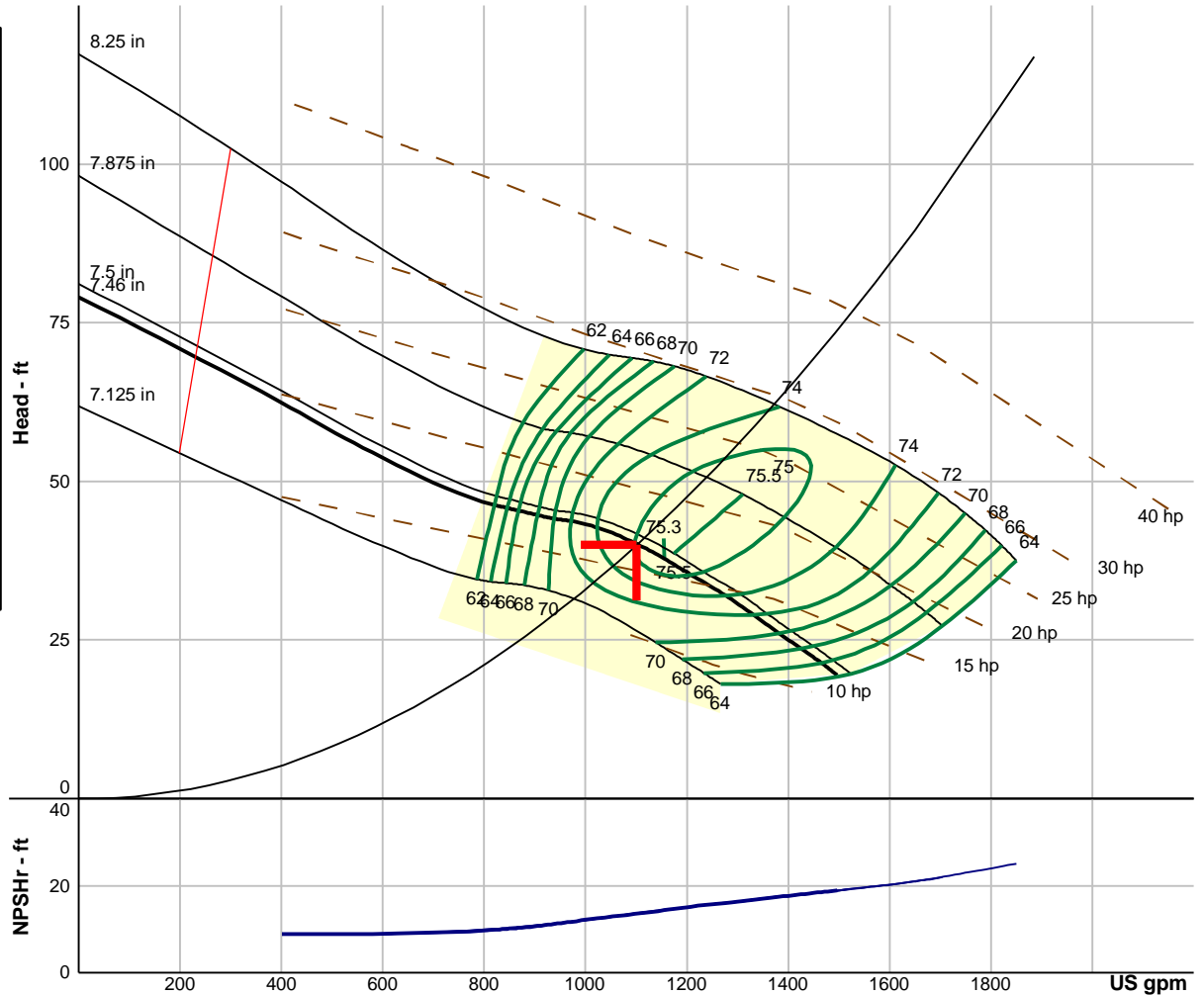

Performance Evaluation:

Flow US gpm	Speed rpm	Head ft	Efficiency %	Power hp	NPSHr ft
1320	1770	29.6	72.4	13.6	16.7
1100	1770	40.2	75	14.9	13.6
880	1770	45.2	66.7	15	10.5
660	1770	51.8	50.4	17.1	9.31
440	1770	60.7	34.9	19.2	9

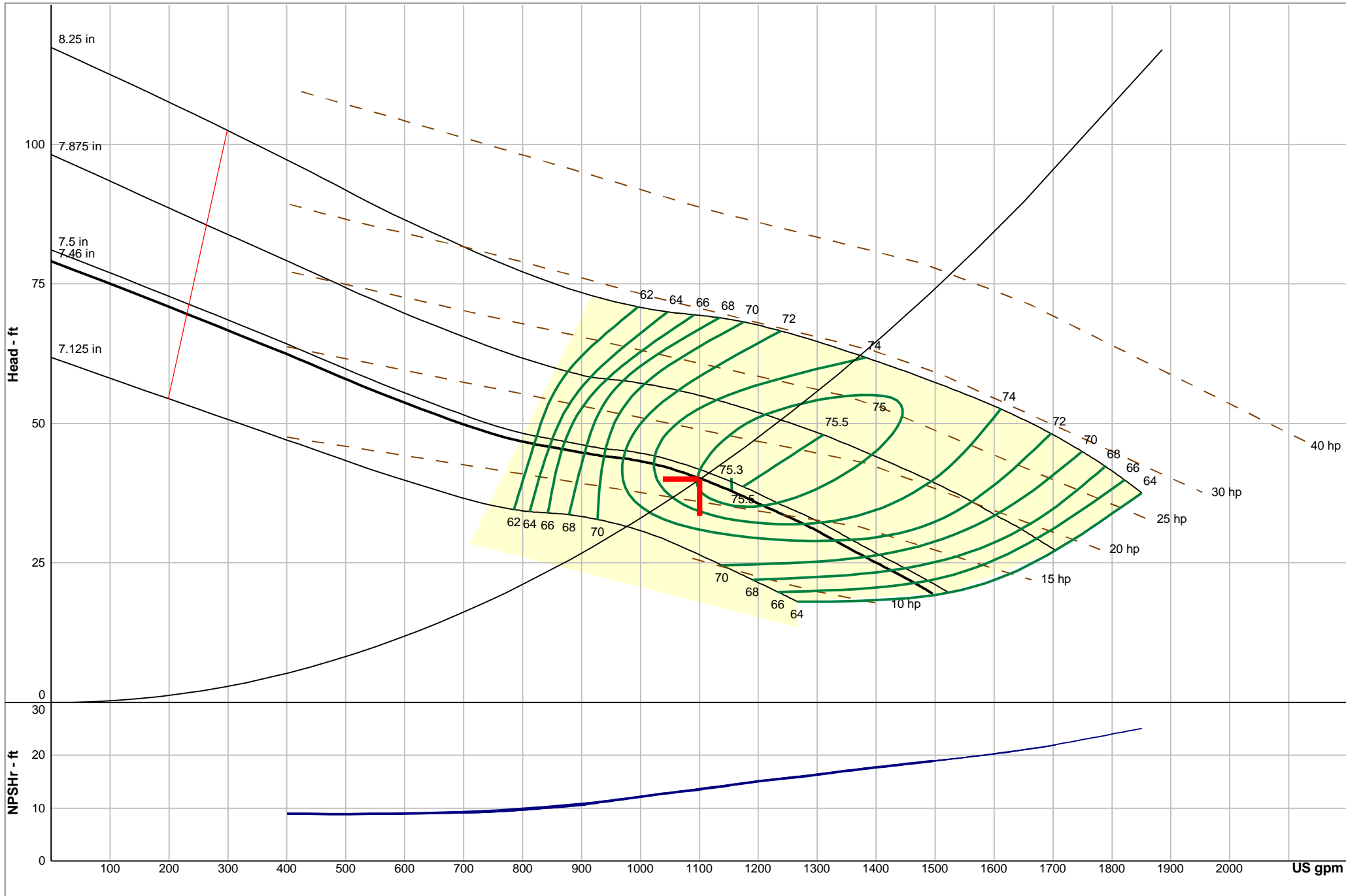

Company: National Pump & Process, Inc.
 Name:
 2/10/2025

Hydroflo Pumps USA, Inc.
 Catalog: Hydroflo VS Pumps.60, Vers 18.3
 Vertical - 1800 rpm
 Design Point: 1100 US gpm, 40 ft

Size: 9ZC (2 stage)
 Speed: 1770 rpm
 Dia: 7.46 in
 Curve: 010311
 Impeller: 9ZC SS ENCL.



**TPL and Total Column Lengths +/- 1.5"
All Dimensions In Inches

PROJECT SPECIFICATIONS

Date: 2/10/2025
 Job:
 Config #: C-58401-w
 GPM: 1100
 Head FT: 40
 Pump Model: 9ZC - 2 Stage
 Imp. Type: 9ZC SS ENCL.
 Pump Materials: Ductile Iron / 201SS
 Bowl Bearings: B10 C932 Bronze
 Bowl Shaft: 1.5000" 416SS
 Strainer Type: N/A Not Wanted
 Column: 8" x .322" wall
 Lineshaft: 1.1875" 416SS
 Lineshaft Brgs: Rubber
 Discharge Head: Fabricated Steel Head
 Discharge Flange: 8" 150# RF Discharge Flange
 Seal Type: John Crane #1345 Packing
 Head Shaft: 1.1875" 416SS
 Foundation Plate: Steel

Minimum Submergence

Minimum Submergence from bottom of suction for vortex suppression: 33". *This does NOT include NPSHr needs.

4.0

29.38

1.25

DRIVER INFORMATION

Mfr: US
 Enclosure: VHS-WP1
 HP: 20
 RPM: 1800
 Phase/Volt: 3/230/460
 Frame: 256TPH
 Efficiency: Premium Efficient
 NRR or SRC: NRR

Column Note

The column dimensions, on this side, do not include the bearing spiders.

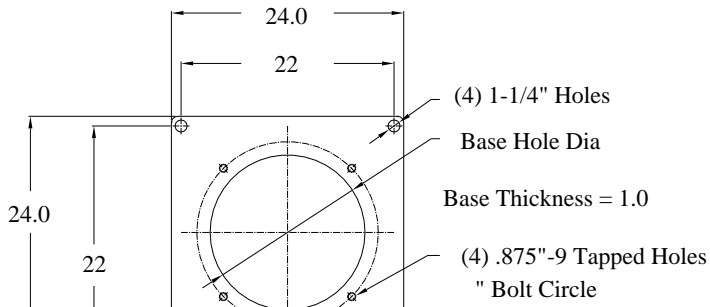
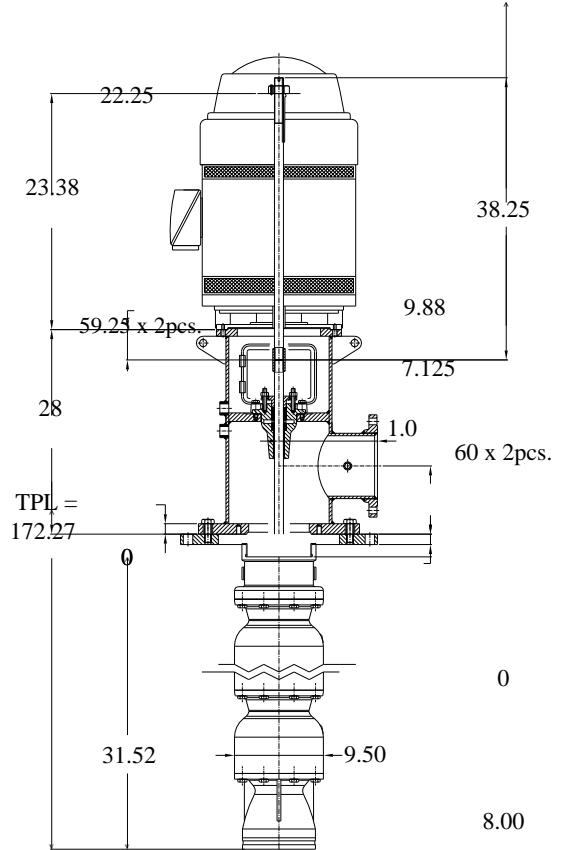

FOUNDATION PLATE

Estimated Shipping Weight: 2323 Lbs.

NOT FOR CONSTRUCTION

NOTICE

This drawing is the confidential property of Hydroflo Pumps USA, Inc., a Taco Group Company and is furnished for your information only and must not be made public or copied and must be returned on demand. Manufacture of parts per this drawing is expressly forbidden except by written authorization from Hydroflo Pumps USA, Inc., a Taco Group Company. All rights of design and invention are reserved and patents pending.



HYDROFLO PUMPS USA, INC.
 7118 LOBLOLLY PINE BLVD.
 FAIRVIEW, TN 37062
 PHONE: 615.799.9662
 FAX: 615.799.5654

National Pump & Process, Inc.
9ZC - 2 Stage Product Lubricated Vertical Turbine Pump System

REV	DATE	REVISION	CH

REFERENCE	HYDROFLO PUMPS INC. WORK ORDER NO.	CUSTOMER P.O. NO.	General Arrangement Design Specifications		
PUMP S.N.	NO. REQD: Qty	DR BY: Config DATE: 2/10/2025	DWG. NO.	SHT.	REV.
MATERIAL: NOTED		CK BY: DATE:			

THIS DRAWING MUST BE SIGNED AND RETURNED WITH THE ORDER

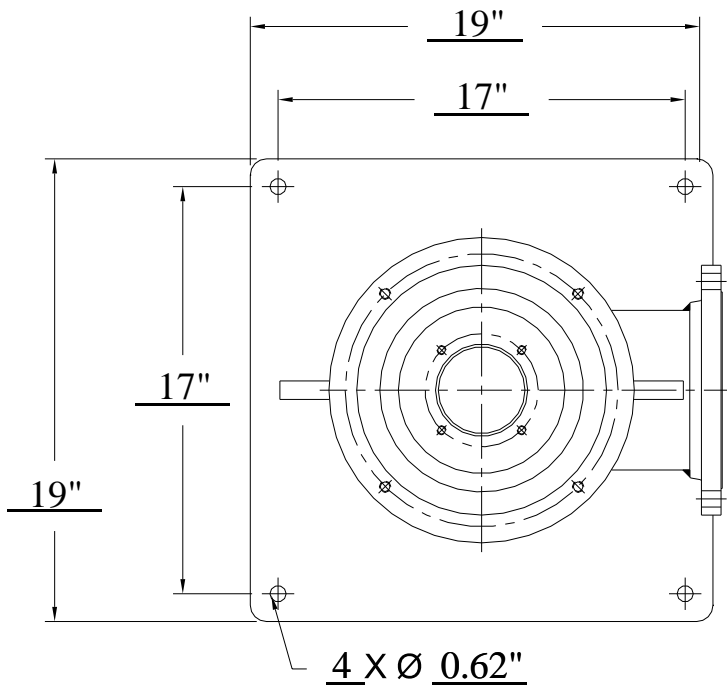

SQUARE BASE

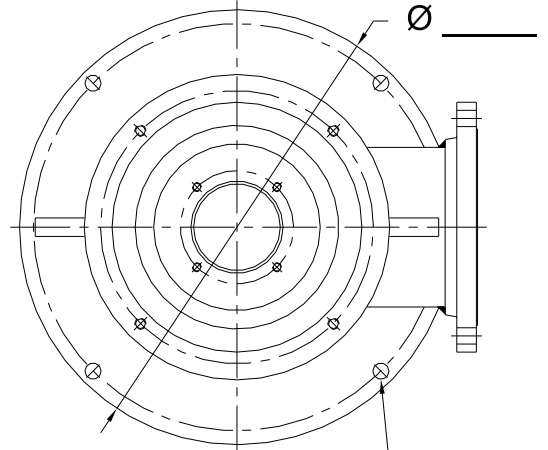

___ X Ø ___ HOLES THRU
EQ. SPACED ON Ø ___ B.C.

~~**ROUND BASE**~~

8 " HF F-TYPE FAB. HEAD

SPECIAL NOTES:

APPROVED BY:

DATE: / /

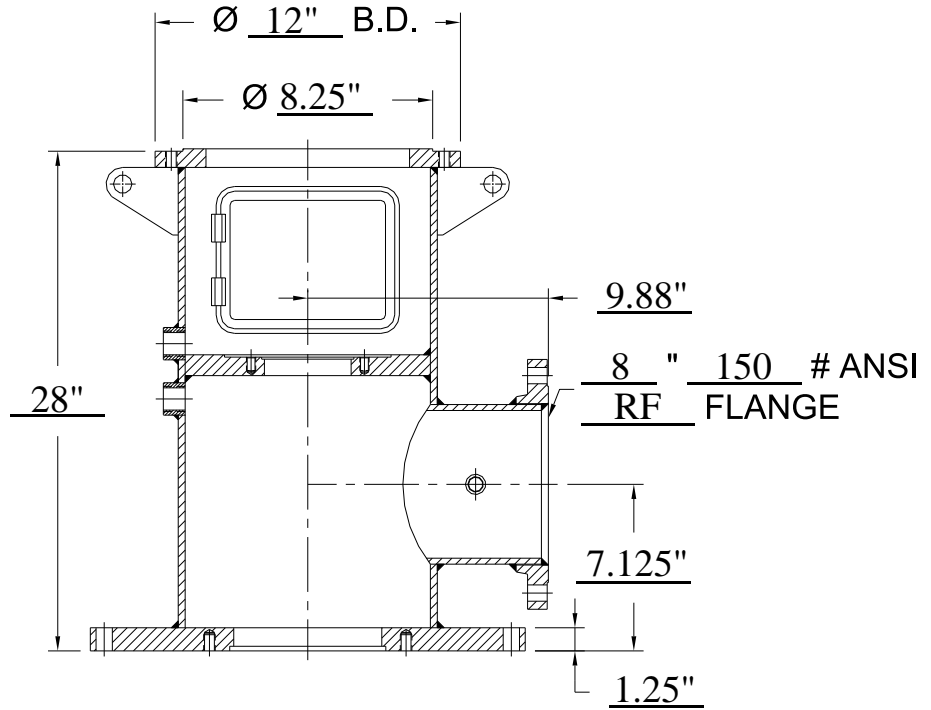

SIDE VIEW

NOTICE

THIS DRAWING IS THE CONFIDENTIAL PROPERTY OF HYDROFLO PUMPS USA INC. AND IS FURNISHED FOR YOUR INFORMATION ONLY AND MUST NOT BE MADE PUBLIC OR COPIED AND MUST BE RETURNED ON DEMAND. MANUFACTURE OF PARTS PER THIS DRAWING IS EXPRESSLY FORBIDDEN EXCEPT BY WRITTEN AUTHORIZATION FROM HYDROFLO PUMPS USA INC. ALL RIGHTS OF DESIGN AND INVENTION ARE RESERVED AND PATENTS PENDING.



7118 LOBLOLLY PINE BLVD.
FAIRVIEW, TN 37062
PHONE: 615-799-9662
FAX: 615-799-5654

National Pump & Process, Inc.
9ZC - 2 Stage Water Lube Pump
F-Style Fabricated Head Worksheet

REV	DATE	REVISION	CH

CONFIGURATION No.: C-58401-w		HF F-Type Fabricated Head Measurements Worksheet		
CUSTOMER P.O.:		Form NO.	SHT.	Rev
DR BY:	DATE:	HFFFDH01R0	1 of 1	0
CK BY: --	DATE: --/--/--			

Dimensions In Inches Unless Otherwise Noted HYDROFLO PUMPS INC.

Material: Work Sheet Date: 09/02/2015

ItemNo.	Qty.	Description	Material Grade
1	1	Bowl Shaft	416 Stainless Steel
5	1	Bearing - Oil Tube Adapter (Half Bearing)	BRZ C932
9	2	Pipe Plug - Discharge	A-197 Black Iron
10	1	Bearing - Discharge Case	C93200 Bronze
12	1	Discharge Case	A-536 GR. 65-45-12
14	12	Bolt - Discharge Case	18-8 Stainless Steel
16	2	Bowl	A-536 GR. 65-45-12
18	2	Bearing - Bowl	C93200 Bronze
19	2	Impeller Collet	316 Stainless Steel
20	2	Impeller	201 Stainless Steel
23	12	Bolt - Bowl	18-8 Stainless Steel
24	12	Bolt - Suction	18-8 Stainless Steel
25	1	Suction - Threaded	A-536 GR. 65-45-12
27	1	Sand Collar	201 Stainless Steel
28	1	Bearing - Suction	C93200 Bronze
29	1	Pipe Plug - Suction	A-197 Black Iron

ZOOM FOR DETAIL

NOT TO SCALE

PROJECT SPECIFICATIONS

Date: 2/10/2025
 Job:
 Config #: C-58401-w
 GPM: 1100
 Head FT: 40
 Pump Model: 9ZC - 2 Stage
 Imp. Type: 9ZC SS ENCL.
 Pump Materials: Ductile Iron / 201SS
 Bowl Shaft Dia: 1.5000

DRIVER INFORMATION

Mfr: US
 Enclosure: VHS-WP1
 HP: 20
 RPM: 1800
 Phase/Volt: 3/230/460
 Frame: 256TPH
 Efficiency: Premium Efficient
 NRR or SRC: NRR

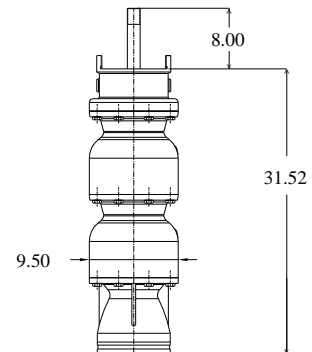
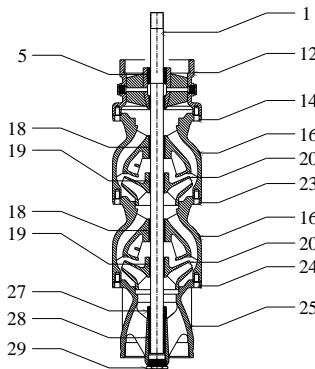

Estimated Bowl Assy
 Weight: 190 Lbs.

NOT FOR CONSTRUCTION

NOTICE

This drawing is the confidential property of Hydroflo Pumps USA, Inc., a Taco Group Company and is furnished for your Information only and must not be made public or copied and must be returned on demand. Manufacture of parts per this drawing is expressly forbidden except by written authorization from Hydroflo Pumps USA, Inc., a Taco Group Company. All rights of design and invention are reserved and patents pending.



HYDROFLO PUMPS USA, INC.
 7118 LOBLOLLY PINE BLVD.
 FAIRVIEW, TN 37062
 PHONE: 615.799.9662
 FAX: 615.799.5654

National Pump & Process, Inc.
9ZC - 2 Stage Water Lube
Vertical Turbine Pump System

REV	DATE	REVISION	CH

REFERENCE	HYDROFLO PUMPS INC. WORK ORDER NO.	CUSTOMER P.O. NO.	General Arrangement Design Specifications		
PUMP S.N.	NO. REQD: Qty	DR BY: Config DATE: 2/10/2025	DWG. NO.	SHT.	REV.
MATERIAL: NOTED		CK BY: DATE:			

ItemNo.	Qty.	Description	Material Grade
1	1	Bowl Shaft	416 Stainless Steel
5	1	Bearing - Oil Tube Adapter (Half Bearing)	BRZ C932
9	2	Pipe Plug - Discharge	A-197 Black Iron
10	1	Bearing - Discharge Case	C93200 Bronze
12	1	Discharge Case	A-536 GR. 65-45-12
14	12	Bolt - Discharge Case	18-8 Stainless Steel
16	2	Bowl	A-536 GR. 65-45-12
18	2	Bearing - Bowl	C93200 Bronze
19	2	Impeller Collet	316 Stainless Steel
20	2	Impeller	201 Stainless Steel
23	12	Bolt - Bowl	18-8 Stainless Steel
24	12	Bolt - Suction	18-8 Stainless Steel
25	1	Suction - Threaded	A-536 GR. 65-45-12
27	1	Sand Collar	201 Stainless Steel
28	1	Bearing - Suction	C93200 Bronze
29	1	Pipe Plug - Suction	A-197 Black Iron

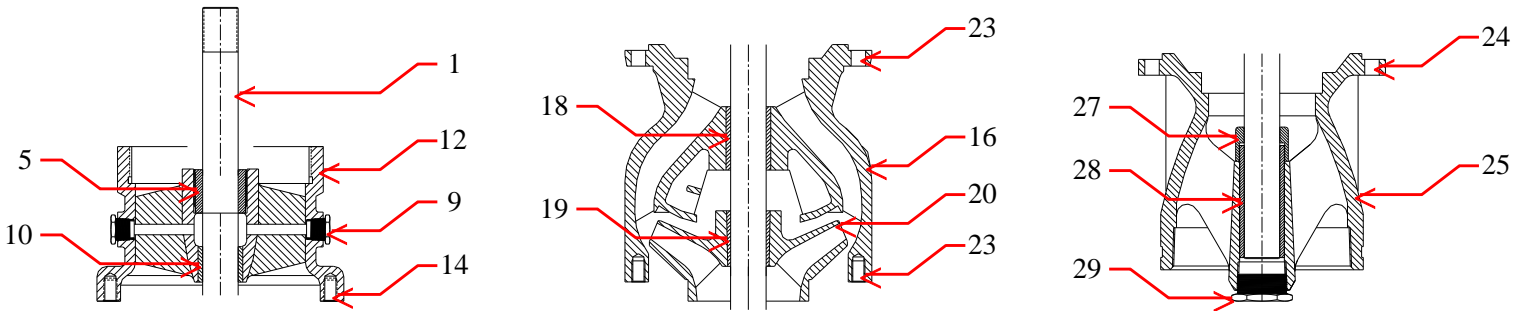

Pump Model: 9ZC - 2 Stage

NOT FOR CONSTRUCTION

Config #: C-58401-w

NOTICE

This drawing is the confidential property of Hydroflo Pumps USA, Inc., a Taco Group Company and is furnished for your information only and must not be made public or copied and must be returned on demand. Manufacture of parts per this drawing is expressly forbidden except by written authorization from Hydroflo Pumps USA, Inc., a Taco Group Company. All rights of design and invention are reserved and patents pending.



HYDROFLO PUMPS USA, INC.
 7118 LOBLOLLY PINE BLVD.
 FAIRVIEW, TN 37062
 PHONE: 615.799.9662
 FAX: 615.799.5654

National Pump & Process, Inc.
9ZC - 2 Stage Water Lube
Vertical Turbine Pump System

REV	DATE	REVISION	CH

REFERENCE		HYDROFLO PUMPS INC. WORK ORDER NO.		CUSTOMER P.O. NO.		General Arrangement Design Specifications	
PUMP S.N.		NO. REQD: Qty		DR BY: Config DATE: 2/10/2025		DWG. NO.	
MATERIAL: NOTED				CK BY: DATE:		SHT.	
						REV.	

NIDEC MOTOR CORPORATION

8050 WEST FLORISSANT AVE.
ST. LOUIS, MO 63136



DATE: 2/10/2025

P.O. NO.: FZ74
Order/Line NO.: 25886 MN 100

TO:

Model Number: FZ74
Catalog Number: HO20P2BLF
VHS Weather Protected
CONF,MOTOR,VHS WPI

REVISIONS:
(NONE)

**ALL DOCUMENTS HEREIN ARE CONSIDERED CERTIFIED BY NIDEC MOTOR CORPORATION.
THANK YOU FOR YOUR ORDER AND THE OPPORTUNITY TO SERVE YOU.**

Features:

Horsepower 00020.00~00000.00 ~ KW: 14.92
Enclosure WPI
Poles 04~00 ~ RPM: 1800~0
Frame Size 256~TPH
Phase/Frequency/Voltage.. 3~060~230/460
Winding Type Random Wound
Service Factor 1.15
Insulation Class Class "F" ~ Insulife 1000
Altitude In Feet (Max) .. 3300 Ft.(1000 M) ~ +40 C
Efficiency Class Premium Efficiency
Application Vertical Centrifugal Pump
Customer Part Number
12" Base ~ Coupling Size: 1" Bore, 1/4" Key
Non-Reverse Ratchet ~ Steady Bushing Not Requested
Pricebook Thrust Value (lbs).. 3300
Customer Down Thrust (lbs) ... 3200
Customer Shutoff Thrust (lbs).
Up Thrust (lbs): ~
Temperature Rise (Sine Wave): "B" Rise @ 1.0 SF (Resist)
Starting Method PWS (Dual Volt-Low Volt Only)
Duty Cycle Continuous Duty
Efficiency Value 93.0 % ~ Typical
Load Inertia: NEMA ~ Standard Inertia: 99.00 LB-FT2
Number Of Starts Per Hour: NEMA
Motor Type Code AUS
Rotor Inertia (LB-FT²) 2.27 LB-FT²
Qty. of Bearings PE (Shaft) 1
Qty. of Bearings SE (OPP) 1
Bearing Number PE (Shaft) 7310 BEP
Bearing Number SE (OPP) 6210-2Z-J/C3

Nidec trademarks followed by the ® symbol are registered with the U.S. Patent and Trademark Office.

NIDEC MOTOR CORPORATION

8050 WEST FLORISSANT AVE.
ST. LOUIS, MO 63136



DATE: 2/10/2025

P.O. NO.: FZ74
Order/Line NO.: 25886 MN 100

TO:

Model Number: FZ74
Catalog Number: HO20P2BLF
VHS Weather Protected
CONF,MOTOR,VHS WPI

REVISIONS:
(NONE)

**ALL DOCUMENTS HEREIN ARE CONSIDERED CERTIFIED BY NIDEC MOTOR CORPORATION.
THANK YOU FOR YOUR ORDER AND THE OPPORTUNITY TO SERVE YOU.**

Accessories:

Counter CW Rotation FODE
115 Volt Space Heaters
Special Balance
Stamp Following On Main N/P:
100% HT
Standard Leadtime: NA
F.O.B.:

USE THE DATA PROVIDED BELOW TO SELECT THE APPROPRIATE DIMENSION PRINT

Horsepower	20
Pole(s)	04
Voltage(s)	460-230
Frame Size	256TPH
Outlet Box AF	2.59
Outlet Box AA	1.50

Nidec trademarks followed by the ® symbol are registered with the U.S. Patent and Trademark Office.

EFFECTIVE:
27-AUG-24

SUPERSEDES:
07-JUL-16

DIMENSION PRINT

OVERSIZED OUTLET BOX

FRAME: 250TP, TPA, TPH
BASIC TYPE: AU

PRINT:
09-2289-03

SHEET:
1 OF 1

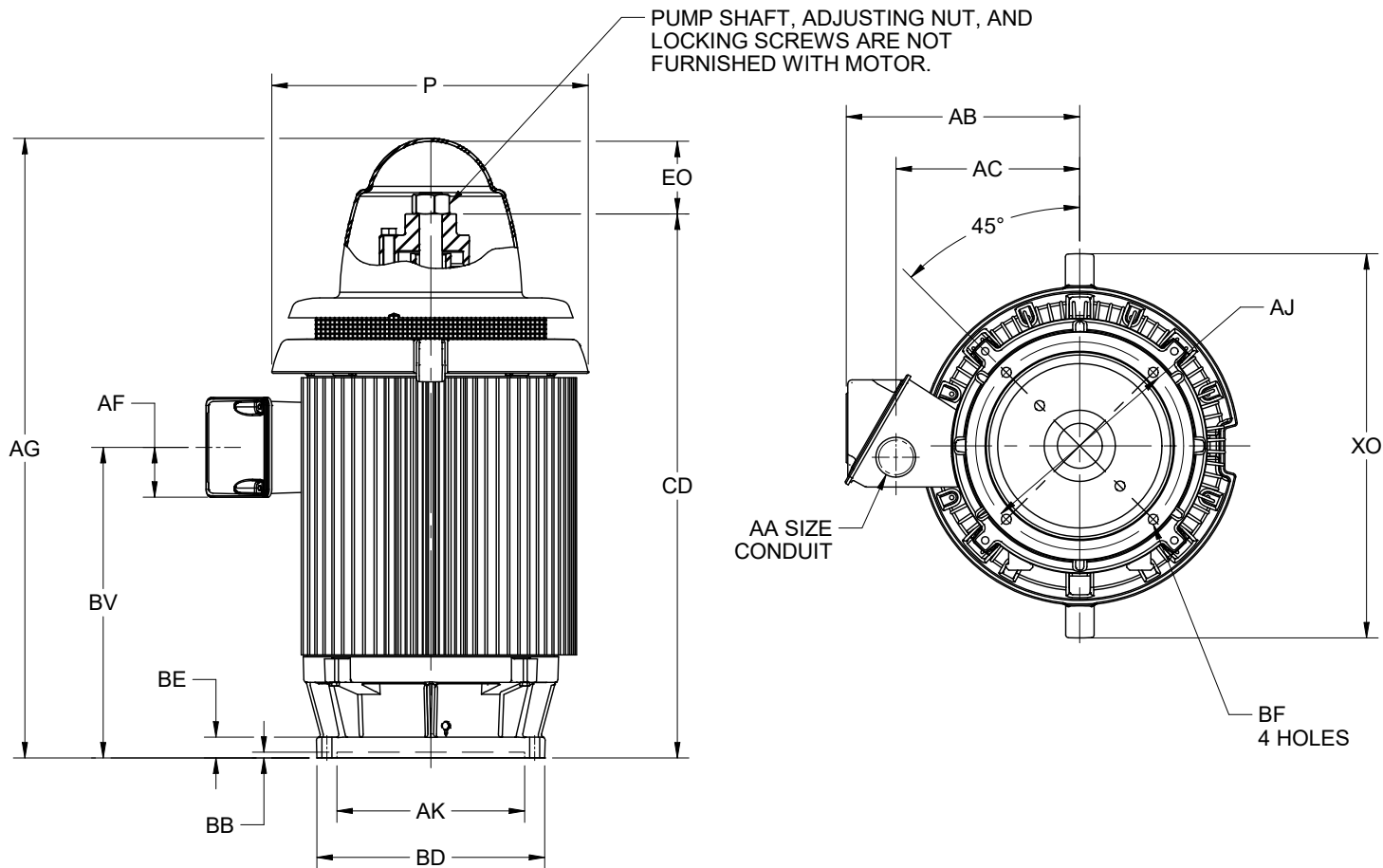

ALL DIMENSIONS ARE IN INCHES AND MILLIMETERS

UNITS	P ²	AA	AB	AC	AF	AG ⁵	BB MIN	BE	BV ⁵	CD ⁵	EO	XO
IN	14.00	1.50	11.00	8.31	2.59	26.75	.25	.94	13.50	23.38	3.25	16.88
MM	356		279	211	66	679	6	24	343	594	83	429

FRAME	UNITS	AJ	AK	BD MAX	BF
254,256TP	IN	9.125	8.250	10.00	.44
	MM	231.78	209.55	254	11
254,256TPA	IN	14.750	13.500	16.50	.69
	MM	374.65	342.90	419	18
254,256TPH	IN	9.125	8.250	12.00	.44
	MM	231.78	209.55	305	11

TOLERANCES	8.250 AK	13.500 AK
FACE RUNOUT	.004 T.I.R.	.007 T.I.R.
PERMISSIBLE ECCENTRICITY OF MOUNTING RABBET	.004 T.I.R.	.007 T.I.R.
TOLERANCE ON AK-DIMENSION	+.003	+.005

1. ALL ROUGH DIMENSIONS MAY VARY BY .25" IN DUE TO CASTING AND/OR FABRICATION VARIATIONS.
2. LARGEST MOTOR WIDTH.
3. TOLERANCES SHOWN ARE IN INCHES ONLY.

4. CONDUIT OPENINGS MAY BE LOCATED IN STEPS OF 180 DEGREE REGARDLESS OF LOCATION. STANDARD AS SHOWN WITH CONDUIT OPENING DOWN.
5. DIMENSIONS SHOWN ARE FOR ALL RATINGS EXCEPT 20 HP, 4 POLE, TYPE AUE AND AUJ. FOR THIS RATING THE DIMENSIONS ARE: AG=28.13 (715 MM)
CD=24.75 (629 MM)
BV=15.38 (391 MM)

09-2289/E

Nidec Motor Corporation
St. Louis, Missouri

INFORMATION DISCLOSED ON THIS DOCUMENT IS CONSIDERED PROPRIETARY AND SHALL NOT BE REPRODUCED OR DISCLOSED WITHOUT WRITTEN CONSENT OF NIDEC MOTOR CORPORATION



ISSUED BY
G. MARTINEZ
APPROVED BY
L. ARROYO

IHP_DP_NMCA (MAR-2011) SOLIDEDGE

NAMEPLATE DATA

CATALOG NUMBER: <input style="width: 100%;" type="text" value="HO20P2BLF"/>	NAMEPLATE PART #: <input style="width: 100%;" type="text" value="422703-007"/>
MODEL <input style="width: 150px;" type="text" value="FZ74"/> FR <input style="width: 150px;" type="text" value="256TPH"/>	TYPE <input style="width: 150px;" type="text" value="AUS"/> ENCL <input style="width: 150px;" type="text" value="WPI"/>
SHAFT END BRG <input style="width: 150px;" type="text" value="7310 BEP - QTY 1"/>	OPP END BRG <input style="width: 150px;" type="text" value="6210-2Z-J/C3 - QTY 1"/>
PH <input style="width: 50px;" type="text" value="3"/> MAX AMB <input style="width: 100px;" type="text" value="40 C"/>	ID# <input style="width: 150px;" type="text"/>
INSUL CLASS <input style="width: 50px;" type="text" value="F"/> Asm. Pos. <input style="width: 150px;" type="text"/>	DUTY <input style="width: 150px;" type="text" value="CONT"/>
HP <input style="width: 50px;" type="text" value="20"/> RPM <input style="width: 100px;" type="text" value="1775"/>	HP <input style="width: 50px;" type="text"/> RPM <input style="width: 100px;" type="text"/>
VOLTS <input style="width: 50px;" type="text" value="460"/> <input style="width: 50px;" type="text" value="230"/>	VOLTS <input style="width: 50px;" type="text"/> <input style="width: 50px;" type="text"/>
FL AMPS <input style="width: 50px;" type="text" value="24.0"/> <input style="width: 50px;" type="text" value="48.0"/>	FL AMPS <input style="width: 50px;" type="text"/> <input style="width: 50px;" type="text"/>
SF AMPS <input style="width: 50px;" type="text" value="27.5"/> <input style="width: 50px;" type="text" value="55.0"/>	SF AMPS <input style="width: 50px;" type="text"/> <input style="width: 50px;" type="text"/>
SF <input style="width: 50px;" type="text" value="1.15"/> DESIGN <input style="width: 50px;" type="text" value="B"/> CODE <input style="width: 50px;" type="text" value="G"/>	SF <input style="width: 50px;" type="text"/> DESIGN <input style="width: 50px;" type="text"/> CODE <input style="width: 50px;" type="text"/>
NEMA NOM EFFICIENCY <input style="width: 50px;" type="text" value="93.0"/> NOM PF <input style="width: 50px;" type="text" value="83.8"/> KiloWatt <input style="width: 50px;" type="text" value="14.92"/>	NEMA NOM EFFICIENCY <input style="width: 50px;" type="text"/> NOM PF <input style="width: 50px;" type="text"/>
GUARANTEED EFFICIENCY <input style="width: 50px;" type="text" value="91.7"/> MAX KVAR <input style="width: 50px;" type="text" value="5.8"/> HZ <input style="width: 50px;" type="text" value="60"/>	GUARANTEED EFFICIENCY <input style="width: 50px;" type="text"/> MAX KVAR <input style="width: 50px;" type="text"/> HZ <input style="width: 50px;" type="text"/>

HAZARDOUS LOCATION DATA (IF APPLICABLE):

DIVISION <input style="width: 100%;" type="text"/>	CLASS I <input style="width: 100%;" type="text"/>	GROUP I <input style="width: 100%;" type="text"/>
TEMP CODE <input style="width: 100%;" type="text"/>	CLASS II <input style="width: 100%;" type="text"/>	GROUP II <input style="width: 100%;" type="text"/>



VFD DATA (IF APPLICABLE):

VOLTS <input style="width: 100%;" type="text"/>	AMPS <input style="width: 100%;" type="text"/>
TORQUE 1 <input style="width: 100%;" type="text"/>	TORQUE 2 <input style="width: 100%;" type="text"/>
VFD LOAD TYPE 1 <input style="width: 100%;" type="text"/>	VFD LOAD TYPE 2 <input style="width: 100%;" type="text"/>
VFD HERTZ RANGE 1 <input style="width: 100%;" type="text"/>	VFD HERTZ RANGE 2 <input style="width: 100%;" type="text"/>
VFD SPEED RANGE 1 <input style="width: 100%;" type="text"/>	VFD SPEED RANGE 2 <input style="width: 100%;" type="text"/>
SERVICE FACTOR <input style="width: 100%;" type="text"/>	FL SLIP <input style="width: 100%;" type="text"/>
NO. POLES <input style="width: 100px;" type="text" value="4"/>	MAGNETIZING AMPS <input style="width: 100px;" type="text" value="8.6"/>
VECTOR MAX RPM <input style="width: 100%;" type="text"/>	Encoder PPR <input style="width: 100%;" type="text"/>
Radians / Seconds <input style="width: 100%;" type="text"/>	Encoder Volts <input style="width: 100%;" type="text"/>

TEAO DATA (IF APPLICABLE):

HP (AIR OVER) <input style="width: 100%;" type="text"/>	HP (AIR OVER M/S) <input style="width: 100%;" type="text"/>	RPM (AIR OVER) <input style="width: 100%;" type="text"/>	RPM (AIR OVER M/S) <input style="width: 100%;" type="text"/>
FPM AIR VELOCITY <input style="width: 100%;" type="text"/>	FPM AIR VELOCITY M/S <input style="width: 100%;" type="text"/>	FPM AIR VELOCITY SEC <input style="width: 100%;" type="text"/>	

ADDITIONAL NAMEPLATE DATA:

Decal / Plate	WD=159833,CP=132839	Customer PN	
Notes		Non Rev Ratchet	NRR
Max Temp Rise	80C RISE/RES@1.00SF	OPP/Upper Oil Cap	GREASE
Thermal (WDG)		SHAFT/Lower Oil Cap	GREASE
Altitude		Usable At	
Regulatory Notes		Regulatory Compliance	
COS		Marine Duty	
Balance	0.08 IN/SEC	Arctic Duty	
3/4 Load Eff.	93.8	Inrush Limit	
Motor Weight (LBS)	300	Direction of Rotation	
Sound Level		Special Note 1	
Vertical Thrust (LBS)	3300	Special Note 2	
Thrust Percentage		Special Note 3	
Bearing Life		Special Note 4	
Starting Method		Special Note 5	
Number of Starts		Special Note 6	100% HT
200/208V 60Hz Max Amps		SH Max. Temp.	
190V 50 hz Max Amps		SH Voltage	SH VOLTS=115V
380V 50 Hz Max Amps		SH Watts	SH WATTS= 48W
NEMA Inertia		Load Inertia	
Sumpheater Voltage		Sumpheater Wattage	
Special Accessory Note 1		Special Accessory Note 16	
Special Accessory Note 2		Special Accessory Note 17	
Special Accessory Note 3		Special Accessory Note 18	
Special Accessory Note 4		Special Accessory Note 19	
Special Accessory Note 5		Special Accessory Note 20	
Special Accessory Note 6		Special Accessory Note 21	
Special Accessory Note 7		Special Accessory Note 22	
Special Accessory Note 8		Special Accessory Note 23	
Special Accessory Note 9		Special Accessory Note 24	
Special Accessory Note 10		Special Accessory Note 25	
Special Accessory Note 11		Special Accessory Note 26	
Special Accessory Note 12		Special Accessory Note 27	
Special Accessory Note 13		Special Accessory Note 28	
Special Accessory Note 14		Special Accessory Note 29	
Special Accessory Note 15		Special Accessory Note 30	
Heater in C/B Voltage		Heater in C/B Watts	
Zone 2 Group		Division 2 Service Factor	
Note 1		Note 2	
Note 3		Note 4	
Note 5		Note 6	
Note 7		Note 8	
Note 9		Note 10	
Note 11		Note 12	
Note 13		Note 14	
Note 15		Note 16	
Note 17		Note 18	
Note 19		Note 20	
Note 21		Note 22	

NIDEC MOTOR CORPORATION
ST. LOUIS, MO

TYPICAL NAMEPLATE DATA
ACTUAL MOTOR NAMEPLATE LAYOUT MAY VARY
SOME FIELDS MAY BE OMITTED



Nidec trademarks followed by the ® symbol are registered with the U.S. Patent and Trademark Office.

MOTOR PERFORMANCE

MODEL NO.	CATALOG NO.	PHASE	TYPE	FRAME
FZ74	HO20P2BLF	3	AUS	256TPH
ORDER NO.		25886	LINE NO.	
MPI:			249236	337543
HP:			20	20
POLES:			4	4
VOLTS:			460	230
HZ:			60	60
SERVICE FACTOR:			1.15	1.15
EFFICIENCY (%):				
S.F.			92.7	92.7
FULL			93	93
3/4			93.8	93.8
1/2			93.3	93.3
1/4			90.1	90.1
POWER FACTOR (%):				
S.F.			84.5	84.5
FULL			83.8	83.8
3/4			80.6	80.6
1/2			72.3	72.3
1/4			51.4	51.4
NO LOAD			5.1	5.1
LOCKED ROTOR			47.4	47.4
AMPS:				
S.F.			27.5	55
FULL			24	48
3/4			18.6	37
1/2			13.9	27.7
1/4			10.1	20.2
NO LOAD			8.6	17.2
LOCKED ROTOR			151	308
NEMA CODE LETTER			G	G
NEMA DESIGN LETTER			B	B
FULL LOAD RPM			1775	1775
NEMA NOMINAL / EFFICIENCY (%)			93	93
GUARANTEED EFFICIENCY (%)			91.7	91.7
MAX KVAR			5.8	5.8
AMBIENT (°C)			40	40
ALTITUDE (FASL)			3300	3300
SAFE STALL TIME-HOT (SEC)			25	25
SOUND PRESSURE (DBA @ 1M)			0	0
TORQUES:				
BREAKDOWN{% F.L.}			253	253
LOCKED ROTOR{% F.L.}			246	271
FULL LOAD{LB-FT}			59.2	59.2

NEMA Nominal and Guaranteed Efficiencies are up to 3,300 feet above sea level and 25 ° C ambient.

The Above Data Is Typical, Sinewave Power Unless Noted Otherwise

NIDEC MOTOR CORPORATION
ST. LOUIS, MO





159833

Motor Wiring Diagram

9 Lead, Dual Voltage, Delta Connection
Part Winding Start (PWS) on Low Voltage

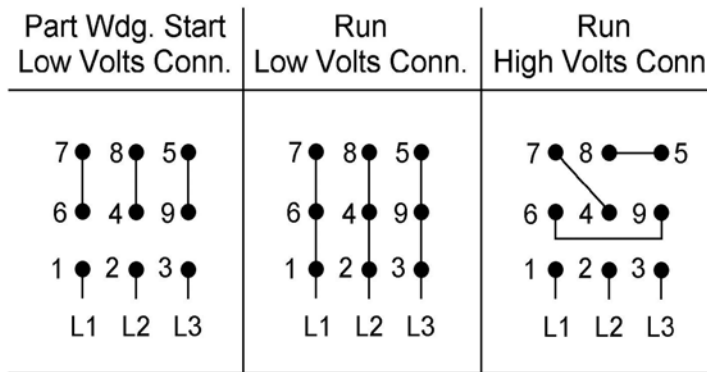

Motor good for across the line starting

Per NEMA MG1 1998-1.75, "A Part-winding Start motor is one which certain specially designed circuits of each phase of the primary winding are initially connected to the supply line. The remaining circuit or circuits of each phase are connected to the supply in parallel with initially connected circuits, at a predetermined point in the starting operation." This is intended to limit the inrush current required to start the motor. NEMA MG1 1998-14.38 states that the motor may not accelerate to full speed in part-winding and may be noisier than when on full winding.

Motors designed by US Motors for Part-winding Start also be used for across the line starting using only the full winding connection. Damage will occur if the motor is operated with load for more than 2 seconds on Part-winding without transition to full winding.

To reverse direction of rotation, interchange leads L1 & L2.

Each lead may have one or more cables comprising that lead. In such case, each cable will be marked with the appropriate lead number.



159833

SPECIAL INFORMATION REGARDING PART WINDING STARTING

This motor is not designed to fully accelerate when started with the part winding start connection shown on the motor connection diagram. In order to avoid damaging the motor when it is started with the part winding start connection, set timers so that the motor starter switches the motor connection from start to run within two seconds from the time that the motor is initially energized. The motor is not expected to fully accelerate before the motor connection is switched to run, but the momentary operation on the start connection should allow time for automatic voltage regulators on the power system to compensate for voltage dip resulting from the high current draw of the motor during acceleration. Thus, voltage dip in the power system will be minimized through proper use of the part winding start connection. Once the motor has been switched over to the run connection, it will finish accelerating up to full speed.

During the time that the motor is operated on the part winding start connection, it is expected that the motor may be noisier than when operated on the run connection and it is also expected that the line amp unbalance between phases may be approximately 100% to 150%. This is due to the adverse effect of harmonics that result from the unbalanced magnetic circuit on the part winding start connection.

For further information regarding characteristics of polyphase induction motors when operated on a part winding start connection, refer to NEMA Publication MG 1-1998 Part 14.38.



970798

SPACE HEATER CONNECTION DIAGRAM

SPACE HEATER LEADS MAY BE LOCATED IN EITHER THE MAIN OUTLET BOX
OR IF SO EQUIPPED, AN AUXILIARY BOX

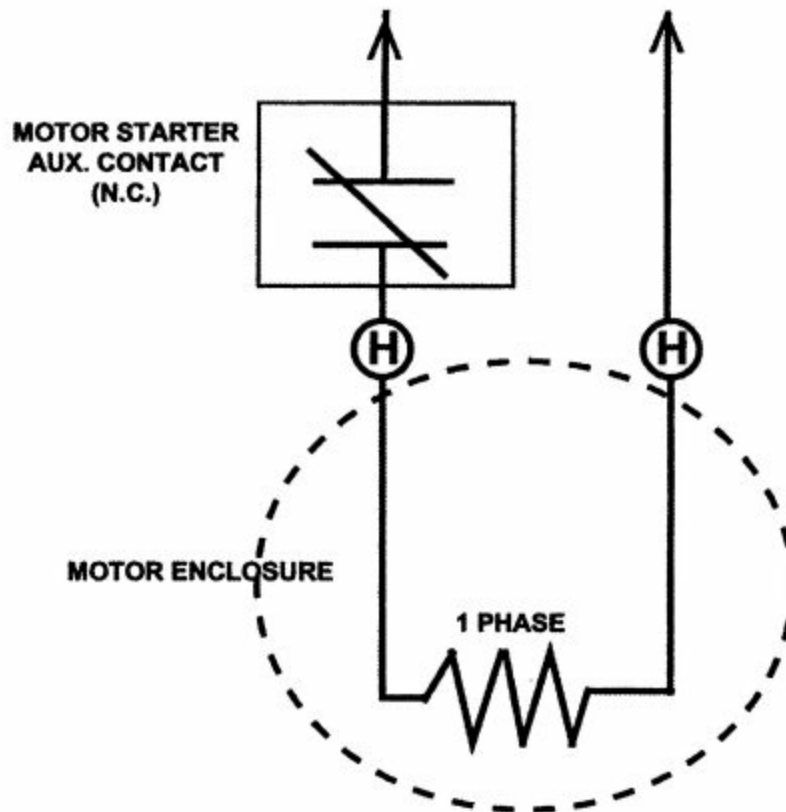

THIS EQUIPMENT IS SUPPLIED WITH ANTI-CONDENSATION HEATERS. HEATERS SHOULD BE ENERGIZED WHEN EQUIPMENT IS NOT OPERATING TO PROTECT UNIT BY PREVENTING INTERNAL CONDENSATION. CONNECT THE "H" OR HEATER LEADS TO

115V VOLTS	48W WATTS RATING
-------------------	-------------------------

SPACE HEATER NAMEPLATE (ON MOTOR)

Revision: 7/30/2008
Mike Cullen

Vertical HOLLOSHAFT Coupling Dimensions

Standard Coupling Dimensions

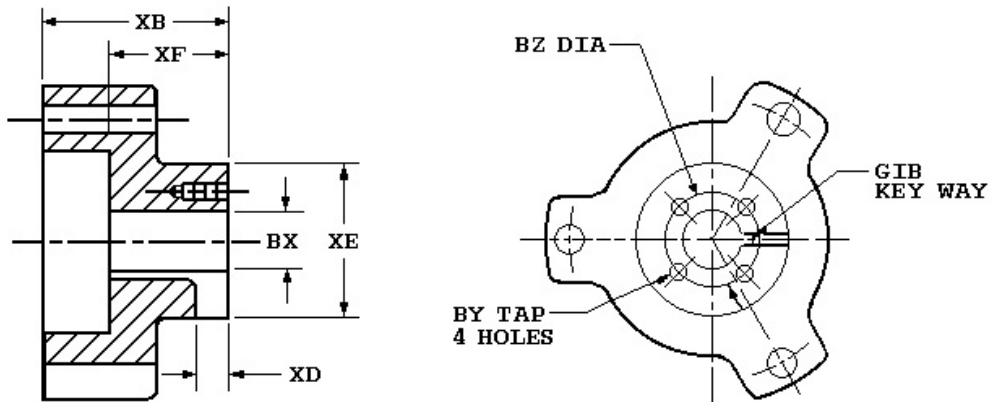

Coupling Part Number	102999
BX Nominal	1
Actual Bore	1.001
BY	10-32
BZ	1 3/8
XB	2 9/16
XD	13/32
XE	2 1/4
XF	1 5/8
SQ. KEY	1/4

Notes:

1. All Rough casting dimensions may vary by 0.25" due to casting variations.
2. All tapped holes are Unified National Course, Right Hand thread.
3. Coupling bore dimension "BX" is machined with a tolerance of $-.000$ ", $+.001$ " up to 1.50" bore inclusive. Larger bores: $-.000$ ", $+.002$ ".



TYPICAL REED CRITICAL FREQUENCY DATA

Note: Motor RCF Test Data can be provided at time of motor shipment through special test.
Please contact your Nidec Motor Corporation representative for more information.

MODEL NO: FZ74
CATALOG NO: HO20P2BLF

Frame: 256TPH Type: AUS

REED CRITICAL FREQUENCY:	78	HZ
CENTER OF GRAVITY:	11	IN
DEFLECTION @ CENTER OF GRAVITY:	0.0016	IN
UNIT WEIGHT:	300	LBS
BASE DIAMETER:	ALL	IN
TOLERANCE ON RCF VALUE:	10%	
DATE:	2/10/2025	



Copyright © 2010 Nidec Motor Corporation. All rights reserved.



DIRECTION OF ROTATION

This motor is unidirectional and can only be operated in one direction to ensure proper cooling.

The motor will be supplied with the industry standard CCW (counter clockwise) rotation as shown below. CW rotation is available upon request.

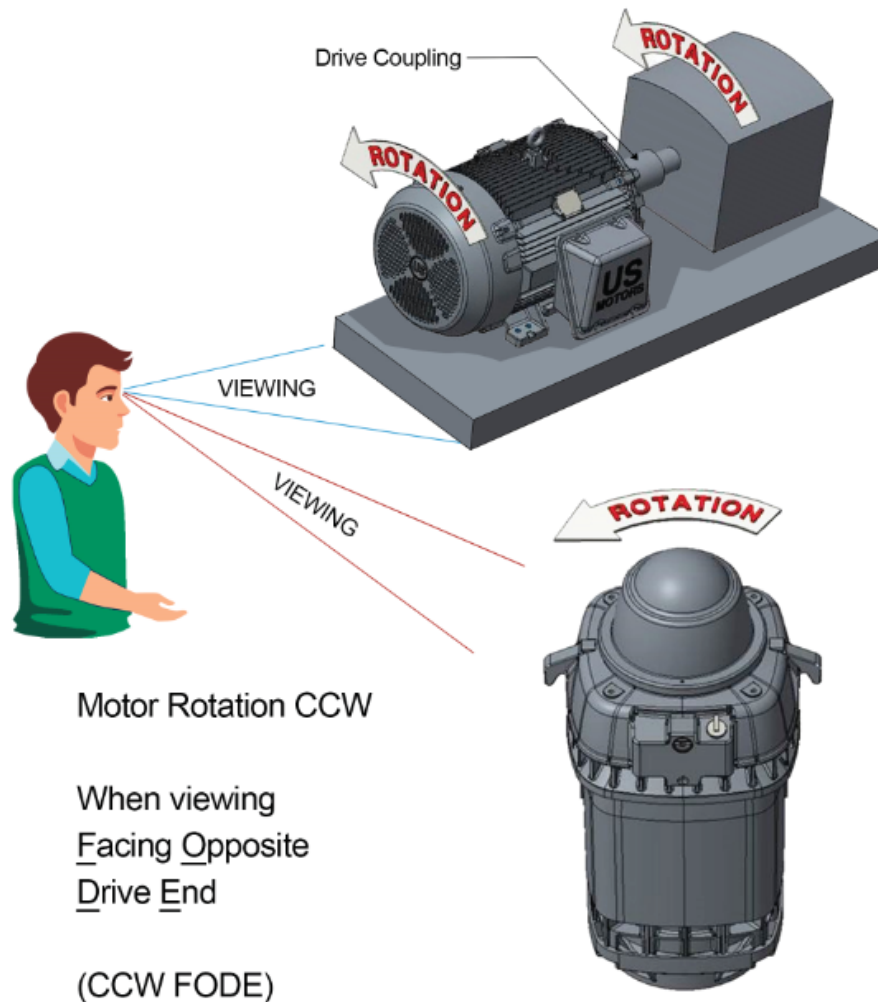

NIDEC MOTOR CORPORATION
ST. LOUIS, MISSOURI

80-289

General Information for Integral Horsepower (IHP) Motors on Variable Frequency Drives (VFDs)

Variable Frequency Drives (VFD)

A VFD is a type of controller used to vary the speed of an electric motor. The VFD takes a fixed AC voltage and frequency and allows it to be adjusted in order to get different speeds from the motor. Motor speed can be varied by changing the frequency of the input power waveform. The equation below shows how the frequency affects the speed of a three phase induction motor.

$$\text{Speed} = \frac{120 * \text{Fundamental Input Frequency}}{\text{Number of Motor Poles}}$$

How does a VFD work?

A VFD takes the fixed frequency and voltage sine wave from the power grid or power station and puts it through a few steps in order to allow the VFD user to vary the frequency and in turn control the motor speed. First it rectifies the AC power into DC Power. Because of this step, a term commonly used instead of VFD is inverter. This only describes one step of what the VFD does to the power waveform. Once rectified into a DC voltage the drive sends the power through a set of transistors or switches. These switches can take the DC waveform and by opening and closing at certain speeds and durations can create an output waveform that mimics the sine wave that is required to drive a three phase electric motor. The output wave form is known as a Pulse Width Modulation (PWM) waveform because the waveform is created by multiple pulses of the switches at short intervals.

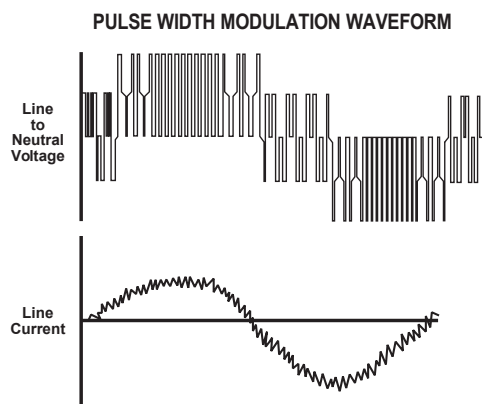

What variables should be considered when deciding whether to power a motor with a VFD?

VFD compatibility with motors is complex. As a result, many variables must be considered when determining the suitability of a particular motor for use with a VFD. These variables include:

- Torque requirements (Constant or Variable)
- Speed Range
- Line / System Voltage
- Cable length between the VFD and the motor
- Drive switching (carrier) frequency
- Motor construction

- VFD dv/dt - winding end turn differential in voltage versus differential in time
- High temperatures or high humidity
- Grounding system

Wider speed ranges, higher voltages, higher switching frequencies, insufficient grounding and increased cable lengths all add to the severity of the application and, therefore, the potential for premature motor failure.

How does a VFD affect the motor?

There are many things to consider when a motor is powered using a VFD or PWM power. When a motor is powered by a PWM waveform the motor windings very often see a large differential voltage, either from phase to phase or turn to turn. When the voltage differential becomes large enough it creates a reaction at the molecular level that converts available oxygen into O₃. This phenomenon is called partial discharge or corona. This reaction creates energy in the form of light and heat. This energy has a corrosive effect on the varnish used to protect the motor windings. PWM waveforms can also magnify shaft voltages which lead to arcing across the bearing and causing premature bearing failure. Corrective action must be taken to mitigate these issues that arise when using an electric motor with a VFD.

How do I protect the motor?

Nidec Motor Corporation (NMC) has developed specific motor designs to decrease the harmful affects that a VFD can have on a motor. NMC's INVERTER GRADE[®] insulation system is the first line of defense against corona and phase to phase faults that can be common when a motor is powered using a PWM waveform. The INVERTER GRADE[®] insulation system is standard on all of NMC's Inverter Duty products. Along with the INVERTER GRADE[®] insulation, thermostats are installed as a minimum protection against over heating the motor. Special consideration must also be given to bearings in motors powered by VFD's. In order to create a low resistance path to ground for built up shaft voltages a shaft grounding device can be used. On larger horsepower motors an insulated bearing system should be used in conjunction with the shaft grounding device when installed, to force the stray shaft voltages to ground. The bearing failures are more prominent on motors with thrust handling bearings. NMC has created an Inverter Duty vertical motor line that not only uses the INVERTER GRADE[®] insulation system, but that also comes standard with a shaft grounding device. On motors that are 100 HP and greater the thrust bearing is also insulated for additional protection.

What does "Inverter Duty" mean?

An Inverter Duty motor should describe a motor that helps mitigate potential failure modes of a motor that is powered by a VFD. Inverter duty motor windings should be able to withstand the voltage spikes per NEMA MG1 Part 31.4.4.2 and protect against overheating when the motor is run at slow speeds. On thrust handling bearings it is apparent that the bearings require additional protection. Inverter Duty vertical motors should have a shaft grounding device to protect the motor bearings from fluting due to voltage discharge through the bearing. On larger motors (100HP and larger) the shaft should also be electrically isolated from the frame in order to aid the shaft grounding ring in discharging the shaft voltages to ground.

*This information applies only to Integral Horsepower (IHP) motors as defined on the Agency Approval page, under UL[®] & CSA[®] listings where indicated.

Thermal Overloads and Single Phase Motors

Motors with thermal overloads installed may not operate properly on a VFD. The current carrying thermal overload is designed for sine wave power. Operation on a VFD may cause nuisance tripping or potentially not protect the motor as would be expected on line power. Thermostats or thermistors installed in the motor and connected properly to the VFD may provide suitable thermal overload protection when operating on a VFD. (consult codes for installation requirements)

Single phase motors and other fractional horsepower ratings are not designed to be operated on a VFD. Within Nidec Motor Corporation standard products, all motors NEMA[®] 48 frame (5.5" diameter) and smaller are not suitable for VFD applications. Three phase 56 and 143/145 frame applications should be noted on the catalog price page; or if in doubt ask a Nidec Motor Corporation technical representative for recommendations on compatibility with a VFD.

Slow Speed Motors

Motors with a base design of slower than six poles require special consideration regarding VFD sizing and minimizing harmonic distortion created at the motor terminals due to cable installation characteristics. Additional external PWM waveform filters and shielded motor cables designed for PWM power may be required to provide acceptable motor life. Harmonic distortion on the output waveform should be kept to a minimum level (less than 10%) mismatch impedance.

690V Applications

Motors that are rated for 690VAC and that will be powered by 690VAC PWM VFDs require the use of an external filter to limit peak voltage spikes and the use of an INVERTER GRADE[®] motor. Where available, an alternative to using an output filter is to upgrade to a 2300V insulation system.

Low Voltage TITAN[®] Motors

When using 449 frame and larger motors on PWM type VFDs consider the use of an external filter and shielded motor cables designed for PWM power to minimize harmonic distortion and peak voltages at the motor terminals. Harmonic distortion on the output waveform should be kept to a minimum level (less than 10%).

Bearing Currents Related to PWM Waveforms

Protection of the motor bearings from shaft currents caused by common mode voltages is becoming a standard feature on Inverter Duty motor products. Some installations may be prone to a voltage discharge condition through the motor bearings called Electrical Discharge Machining (EDM) or fluting. Vertical HOLLOWSHAFT and HOSTILE DUTY World Motor come with grounding devices installed as standard. EDM damage is related to characteristics of the PWM waveform, and the VFD programming, and installations factors.

Bearing Protection on Inverter Duty Vertical Motors

All U.S. MOTORS[®] brand "Inverter Duty" vertical products have a shaft grounding system that allows damaging shaft currents a low resistance path to ground. **Bearings on vertical motors fed by VFD power without this bearing protection are not covered under any warranty.** All other bearing failure is covered per NMC's standard warranty. An electric motor repair shop approved to service U.S. MOTORS[®] brand motors must verify that the cause of the bearing failure was not due to EDM damage.

Guideline For Insulated Anti-Friction Bearings

Bearing insulation is required to prevent circulating shaft currents which can damage bearings. Circulating shaft current can be caused by use of improper power and/or ground cables, improper grounding systems and higher switching frequencies. Finding and correcting the external condition(s) is the responsibility of the system designer or specifying engineer. To prevent circulating shaft current in motors with anti-friction bearings, Nidec Motor Corporation's standard practice is to insulate the non-drive end bearing.

Adjustable Speed Drives produce a common mode voltage condition. To interrupt common mode voltage on induction motors of all sizes, NEMA MG1-2018 Part 31 recommends insulating both bearings. In cases where both anti-friction bearings are insulated, the system designer or specifying engineer should determine whether to apply one or more of the following options to prevent or reduce shaft currents: sinewave filters, line reactors or mechanical devices, such as shaft grounding or an insulated half coupling. Motors with shaft grounding devices are not suitable for installation in hazardous locations unless housed in an enclosure suitable for the specified Division (or Zone), Class and Group(s).

Multiple Motors on a Single VFD

Special considerations are required when multiple motors are powered from a single VFD unit. Most VFD manufacturers can provide guidelines for proper motor thermal considerations and starting/stopping of motors. Cable runs from the VFD and each motor can create conditions that will cause extra stress on the motor winding. Filters may be required at the motor to provide maximum motor life.

Grounding and Cable Installation Guidelines

Proper output winding and grounding practices can be instrumental in minimizing motor related failures caused by PWM waveform characteristics and installation factors. VFD manufacturers typically provide detailed guidelines on the proper grounding of the motor to the VFD and output cable routing. Cabling manufacturers provide recommended cable types for PWM installations and critical information concerning output wiring impedance and capacitance to ground.

Integrated Motor and Inverter

By integrating the motor and inverter at NMC's manufacturing facility, many of the motor compatibility problems are minimized or eliminated. During the manufacturing process, the motor is matched to the inverter characteristics which ensures the winding temperature and torque levels meet the design specification. Since the inverter output wiring to the motor is nearly eliminated, bearing currents are rarely experienced. When the unit is properly grounded, reducing the output cable lengths in conjunction with an inverter grade insulation system and low factory setting of the switching frequency of the inverter drive, results in low risk of voltage peaks produced by the PWM waveform.

Vertical Motors on VFDs

Vertical motors operated on VFD power present unique conditions that may require consideration by the user or installation engineer:

- Locked rotor and drive tripping caused by non-reversing-ratchet operation at low motor speeds. It is not recommended to operate motors at less than 1/4 of synchronous speed. If slow speeds are required contact NMC engineering.
- Unexpected / unacceptable system vibration and or noise levels caused by the torque pulsation characteristics of the PWM waveform, a system critical frequency falling inside the variable speed range of the process or the added harmonic content of the PWM waveform exciting a system component
- Application related problems related to the controlled acceleration/deceleration and torque of the motor on VFD power and the building of system pressure/ load.
- The impact the reduction of pump speed has on the down thrust reflected to the pump motor and any minimum thrust requirements of the motor bearings
- Water hammer during shutdown damaging the non-reversing ratchet

Humidity and Non-operational Conditions

The possible build-up of condensation inside the motor due to storage in an uncontrolled environment or non-operational periods in an installation, can lead to an increased rate of premature winding or bearing failures when combined with the stresses associated with PWM waveform characteristics. Moisture and condensation in and on the motor winding over time can provide tracking paths to ground, lower the resistance of the motor winding to ground, and lower the Corona Inception Voltage (CIV) level of the winding.

Proper storage and maintenance guidelines are important to minimize the potential of premature failures. Space heaters or trickle voltage heating methods are the common methods for drying out a winding that has low resistance readings. **Damage caused by these factors are not covered by the limited warranty provided for the motor unless appropriate heating methods are properly utilized during non-operational periods and prior to motor start-up.**

NEMA[®] Application Guide for AC Adjustable Speed Drive Systems: <http://www.nema.org/stds/acadjustable.cfm#download>

* This information applies only to Integral Horsepower (IHP) motors as defined on the Agency Approval page, under UL[®] & CSA[®] listings where indicated.

Warranty Guidelines for Integral Horsepower (IHP)* Motors on Variable Frequency Drives

Warranty Guidelines

The information in the following section refers to the motor and drive application guidelines and limitations for warranty.

Hazardous Location Motors

Use of a variable frequency drive with the motors in this catalog, intended for use in hazardous locations, is only approved for Division 1, Class I, Group D hazardous location motors with a T2B temperature code, with a limitation of 2:1 constant torque or 10:1 variable torque output. **No other stock hazardous location motors are inherently suitable for operation with a variable frequency drive.** If other requirements are needed, including non-listed Division 2, please contact your Nidec Motor Corporation territory manager to conduct an engineering inquiry.

575 Volt Motors

575 volt motors can be applied on Inverters when output filters are used. Contact the drive manufacturer for filter selection and installation requirements.

Applying INVERTER GRADE® Insulated Motors on Variable Frequency Drives (2, 4, 6 pole)

The products within this catalog labeled “Inverter Duty” or “Vector Duty” are considered INVERTER GRADE® insulated motors. INVERTER GRADE® motors exceed the NEMA® MG-1 Part 31 standard. Nidec Motor Corporation provides a three-year limited warranty on all NEMA® frame INVERTER GRADE® insulated motors and allows long cable runs between the motor and the VFD (limited to 400 feet without output filters). Cable distance can be further limited by hot and humid environments and VFD manufacturers cable limits. These motors may be appropriate for certain severe inverter applications or when the factors relating to the end use application are undefined (such as spares).

Nidec Motor Corporation’s U.S. Motors® brand is available in the following INVERTER GRADE® insulated motors:

- Inverter Duty NEMA® frame motors good for 20:1 Variable Torque & 5:1 Constant Torque, including Vertical Type RUSI (10:1 V.T.)
- Inverter Duty motors rated for 20:1 Constant Torque
- ACCU-Torq® and Vector Duty Motors with full torque to 0 Speed or 5000:1
- 841 Plus® NEMA® Frame Motors

Applying Premium Efficient motors (that do not have INVERTER GRADE® insulation) on Variable Frequency Drives (2, 4, 6 pole)

Premium efficient motors without INVERTER GRADE insulation meet minimum NEMA® MG-1, Section IV, Part 31.4.4.2. These motors can be used with Variable Frequency Drives (with a reduced warranty period) under the following parameters:

- On NEMA® frame 447 and smaller motors, 20:1 speed rating on variable torque loads & 4:1 speed range on constant torque loads.
- On TITAN® 449 and larger frame motors, 10:1 speed rating on variable torque loads.

- On TITAN® frame motors, inquiry required for suitability on constant torque loads.

Cable distances are for reference only and can be further limited by hot and humid environments (refer to Table 1). Refer to specific VFD

Table 1 - Cable Distances			
Maximum Cable Distance VFD to Motor			
Switching Frequency	460 Volt	230 Volt	380 Volt
3 KHz	127 ft	400 ft	218 ft
6 KHz	90 ft	307 ft	154 ft
9 KHz	73 ft	251 ft	126 ft
12 KHz	64 ft	217 ft	109 ft
15 KHz	57 ft	194 ft	98 ft
20 KHz	49 ft	168 ft	85 ft

manufacturers cable limits. Refer to the Motor/ Inverter Compatibility page for special consideration of vertical motor bearings.

Warranty Period Clarifications and Exceptions

Standard Energy Efficient Exclusion

Applying Standard & Energy Efficient Motors on Variable Frequency Drives is not recommended. VFD related failures on standard and energy efficient motors will not be covered under warranty.

Vertical Motor Windings

Premium efficient vertical motors without INVERTER GRADE® insulation that are installed using the criteria described in this document and applied in the correct applications shall have a warranty while powered by a VFD for 12 months from date of installation or 18 months from date of manufacturing whichever comes first. See limited warranty page for horizontal motor warranty periods.

Bearing Exclusion for Thrust Handling Bearings

Bearings used in premium efficient vertical motors, and all thrust handling bearings, that are powered by VFDs without shaft grounding devices or insulated bearings (when required) will not be covered under any warranty for damages caused from being powered by a VFD. All other bearing failure is covered per NMC’s standard warranty. An electric motor repair shop approved to service U.S. MOTORS® brand motors must verify that the cause of the bearing failure was not due to Electrical Discharge Machining.

Medium Voltage and Slow Speed Considerations

Motors that are rated above 700 VAC or that are eight pole and slower require special consideration and installation and are not covered under the warranty guidelines in this document. Motors that are rated above 700VAC have special cable length and voltage differential issues that are specific to the VFD type and manufacture. The motor construction and cost may vary dramatically depending on the VFD topology and construction. Contact your NMC representative with VFD manufacturer name and model type for application and motor construction considerations. Motors that are designed eight pole and slower also require special installation and filters per the drive manufacturer.

* This information applies only to Integral Horsepower (IHP) motors as defined on the Agency Approval page, under UL® & CSA® listings where indicated.



NATIONAL PUMP & PROCESS INC.



National Pump & Process

180 Treat Rd
Aurora, OH, 44020
Phone: (330) 562-0220

Quote #: 2502007
New Hydroflo Intermediate
Pump Install

Cody Zeleny

City of Newton Falls WTP
175 W. River Road
Newton Falls, OH, 44444

Phone: (330) 872-1808
Mobile: 330-719-2175
Email: Waterplant@ci.newtonfalls.oh.us

Date: 18 February 2025
Rep.: Matt Glova
Mobile: (216)-316-3097

Qty	Item #	Name	Price	Total
1	INT INSTALL	<p>Field Service</p> <p>All labor and material to perform the following to on Vertical Turbine Pump Install</p> <p>~Transport the new pump disassembled to the plant</p> <p>~Rig and lower the pump components into the basement of the plant with crane support from customer.</p> <p>~Assemble pump components and lower through the floor into clear well.</p> <p>~Set and level pump on foundation plate</p> <p>~Connect pump discharge to plant piping.</p> <p>~Install new motor onto pump head</p> <p>~Set pump proper operating lift</p> <p>~Motor rotation check</p> <p>~Pump Start up and packing adjustment.</p> <p>Quote does not include concrete work for the new foundation plate work</p> <p>Site duration 2 days</p>	\$7,834.00	\$7,834.00
Sub Total				\$7,834.00
Shipping & Handling				
Taxes			0.000%	\$.00
TOTAL				\$7,834.00







Thank you for your business

	National Pump & Process 180 Treat Rd Aurora, OH, 44020 Phone: (330) 562-0220	Quote #: 21046 Peerless Model 12Ma-1 SN: 128635 Pump Removal
---	--	---

Cody Zeleny City of Newton Falls WTP 175 W. River Road Newton Falls, OH, 44444	Phone: (330) 872-1808 Mobile: 330-719-2175 Email: Waterplant@ci.newtonfalls.oh.us	Date: 17 February 2025 Rep.: Matt Glova Mobile: (216)-316-3097
--	---	--

Qty	Item #	Name	Price	Total
1	REMOVAL	Field Service All labor and material to perform the following for the removal of the Intermediate pump ~ 3 days labor for two technicians totaling 48 hours of straight time and 6 hours of Overtime. Straight time rate @ \$150.00 per hour ~ Rental of additional demolition hammer ~ Manufacturing of column clamp used during normal removal ~ Transport back to National Pump Shop <div style="text-align: center; margin-top: 20px;"> <i>OK 2-18-25 mm</i> </div>	\$13,263.00	\$13,263.00
Sub Total				\$13,263.00
Shipping & Handling				
Taxes			0.000%	\$.00
TOTAL				\$13,263.00

			
---	---	---	---

Thank you for your business



VILLAGE OF NEWTON FALLS, OHIO
ORDINANCE NO.: 2025-05
SPONSOR: Councilpersons Axiotis, Stimpert

AN ORDINANCE RECOGNIZING JACKSON STREET AREAS 44, 45, AND 46 AS PARTS OF AN UNIMPROVED STREET, VACATING AREAS 44, 45, AND 46 OF JACKSON STREET, AND TRANSFERRING THE VACATED SECTIONS TO THE ADJOINING PROPERTY OWNERS

WHEREAS, The Village has recognized that certain areas of Jackson Street will never be an improved street or connect to Warren Road with any other City Street, and;

WHEREAS, those areas of Jackson Street require regular maintenance, including grass mowing and weed trimming, which represent a cost with no benefit to the Village of Newton Falls, and;

WHEREAS, The Village ordered a survey of the unimproved section of Jackson Street and replatted that section into Vacation Areas 44, 45, and 46 as described and shown within Exhibit A, "Vacation Plat Part of Jackson Street", and;

WHEREAS, the Village Council wishes to vacate areas 44, 45, and 46 of Jackson Street; and

WHEREAS, The Village Council recognizes the expressed interest of the property owners of Homeland Addition Plat lots 44, 45, and 46 in acquiring the vacated area adjacent to their respective properties, and the property owners further agree to maintain their respective section according to City Zoning Requirements.

NOW, THEREFORE, the Council of the Village of Newton Falls, State of Ohio, hereby ordains:

SECTION 1. That the Village Council declares Vacation Areas 44, 45, and 46 of Jackson Street to be unimproved, of no use to the Village of Newton Falls, and hereby vacates said areas.

SECTION 2. That the Village Council transfers ownership of Vacated Areas 44, 45, and 46 of Jackson Street that is immediately adjacent to and directly connected to the property of each of the property owners of Homeland Addition Plat lots 44, 45, and 46 accordingly.

SECTION 3. That the Village Council directs the Interim City Manager to execute the transfer of ownership with any and all costs associated with the transfer of each property to be paid by the property owners of Homeland Addition Plat lots 44, 45, and 46 accordingly.

ORDINANCE NO.: 2025-05

PAGE TWO

SECTION 4. That all formal actions of this Council concerning and relating to the adoption of this Ordinance were taken in an open meeting of this Council, and all deliberations of this Council or any of its committees that resulted in such formal action were taken in meetings open to the public and/or in compliance with all legal requirements, including Section 121.22 of the Ohio Revised Code.

SECTION 5. That this Ordinance shall be effective as of the earliest date permitted by law.

PASSED IN COUNCIL THIS _____ DAY OF _____, 2025.

David Hanson, Mayor

Attest:

Michael Acomb, Clerk of Council

Approved as to Legal Form.

Jeff Limbian, Law Director



THOMAS FOX & ASSOCIATES, INC.
3896 MAHONING AVENUE,
YOUNGSTOWN, OHIO 44515
330-799-1501

PLAN PREPARED BY:

VACATION PLAT PART OF JACKSON STREET

PART OF SECTION 2, NEWTON TOWNSHIP
TOWNSHIP 3, RANGE V, CONNECTICUT WESTERN RESERVE
CITY OF NEWTON FALLS VILLAGE
TRUMBULL COUNTY, STATE OF OHIO
HOMELAND ADDITION, VOL. 10, PG 128
HOMELAND ADDITION REVISED PLAT OF LOTS, 46-47-57-58, VOL. 10, PG. 130

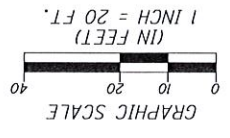
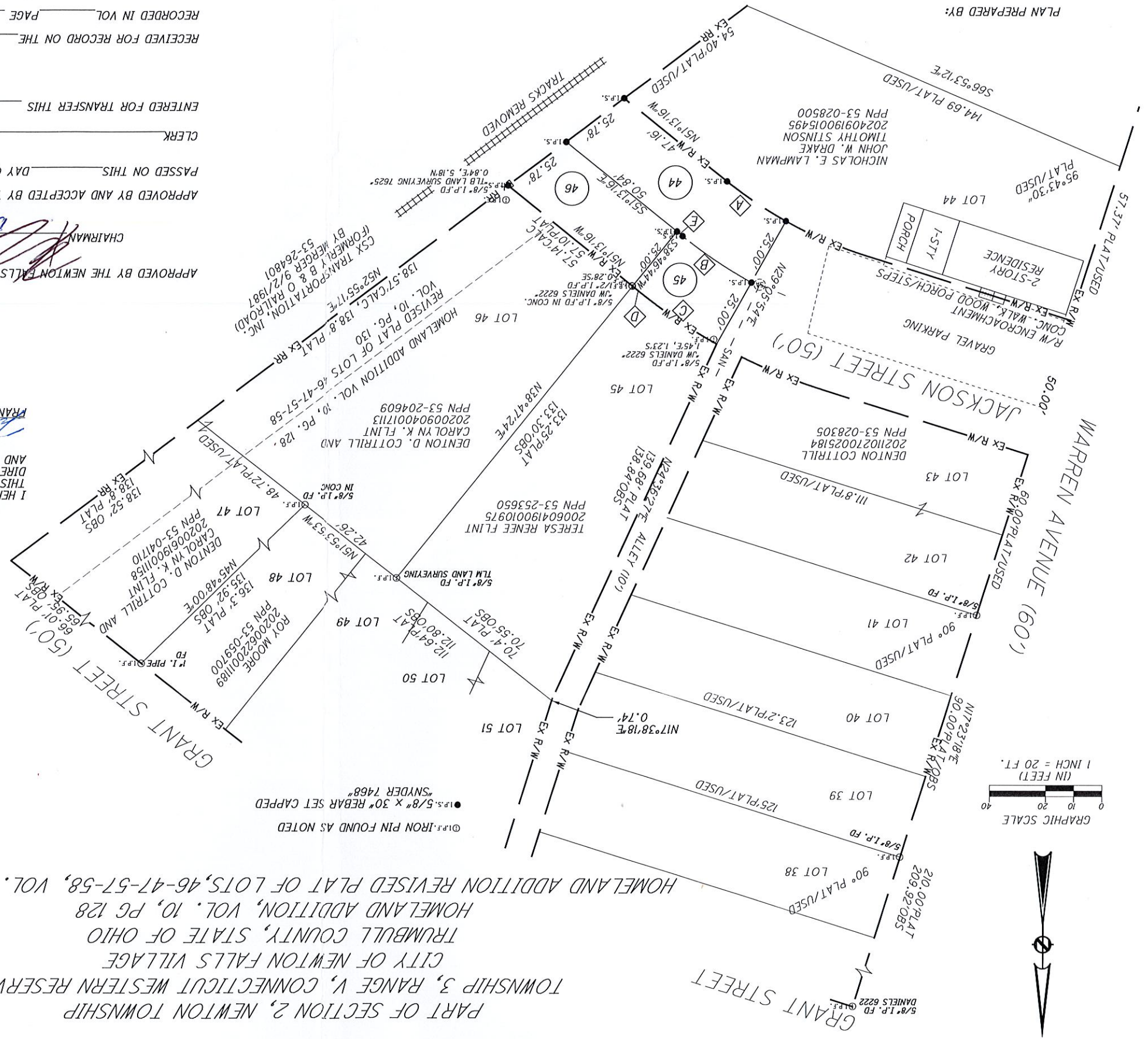

LINE AND CURVE TABLE

KEY	DELTA	RADIUS	ARC LENGTH	BEARING
A	09°40'51"	150.00'	25.34'	N56°03'41"W
B	09°40'51"	175.00'	29.57'	S56°03'41"E
C	09°40'51"	200.00'	33.79'	S56°03'41"E
D			2.62'	S51°13'16"E
Approved by Newton Falls Planning Commission				NS1°13'16"W

Approved by John M. Spellich
Newton Falls Zoning Inspector

Signed *John M. Spellich*
Date *May 17 2025*

I HEREBY CERTIFY, TO THE BEST OF MY KNOWLEDGE AND BELIEF THIS PLAT IS A TRUE DELINEATION OF A SURVEY MADE AT THE DIRECTION OF NEWTON FALLS BY THOMAS FOX & ASSOCIATES, INC. AND THAT ALL MONUMENTS SHOWN ARE IN PLACE.
FRANKLIN D. SNYDER, JR., P.S. NO. S-7468
DATE *11/27/2024*

VACATED RW AREAS =
PARCEL 44 = 0.044 AC. (1919 S.F.)
PARCEL 45 = 0.020 AC. (857 S.F.)
PARCEL 46 = 0.031 AC. (1349 S.F.)
TOTAL = 0.095 AC. (4125 S.F.)

APPROVED BY THE NEWTON FALLS PLANNING COMMISSION THIS *7* DAY OF *January* 2025
CHAIRMAN *John Spellich*
SECRETARY *Brian Kopp*

PASSED ON THIS _____ DAY OF _____, 2024,
CLERK _____
MAYOR _____
ENTERED FOR TRANSFER THIS _____ DAY OF _____, 2024.
TRUMBULL COUNTY AUDITOR _____
RECEIVED FOR RECORD ON THE _____ DAY OF _____, 2024, AT _____ O'CLOCK
PAGE _____ OF THE TRUMBULL COUNTY RECORD OF PLATS
ON THE _____ DAY OF _____, 2024



BASIS FOR BEARINGS:
ALL BEARINGS SHOWN ARE FOR PROJECT USE ONLY.
BEARINGS ARE BASED ON GRID NORTH OF THE OHIO DEPARTMENT OF TRANSPORTATION, TRUMBULL COUNTY COORDINATE SYSTEM BY GNSS RTN MEASUREMENTS IN OCTOBER, 2024.



THOMAS FOK & ASSOCIATES, INC.
3896 MAHONING AVENUE
YOUNGSTOWN, OHIO 44515
330-799-1501

PLAN PREPARED BY:

VACATION PLAT PART OF JACKSON STREET

PART OF SECTION 2, NEWTON TOWNSHIP
TOWNSHIP 3, RANGE V, CONNECTICUT WESTERN RESERVE
CITY OF NEWTON FALLS VILLAGE
TRUMBULL COUNTY, STATE OF OHIO
HOMELAND ADDITION, VOL. 10, PG 128
HOMELAND ADDITION REVISED PLAT OF LOTS, 46-47-57-58, VOL. 10, PG. 130

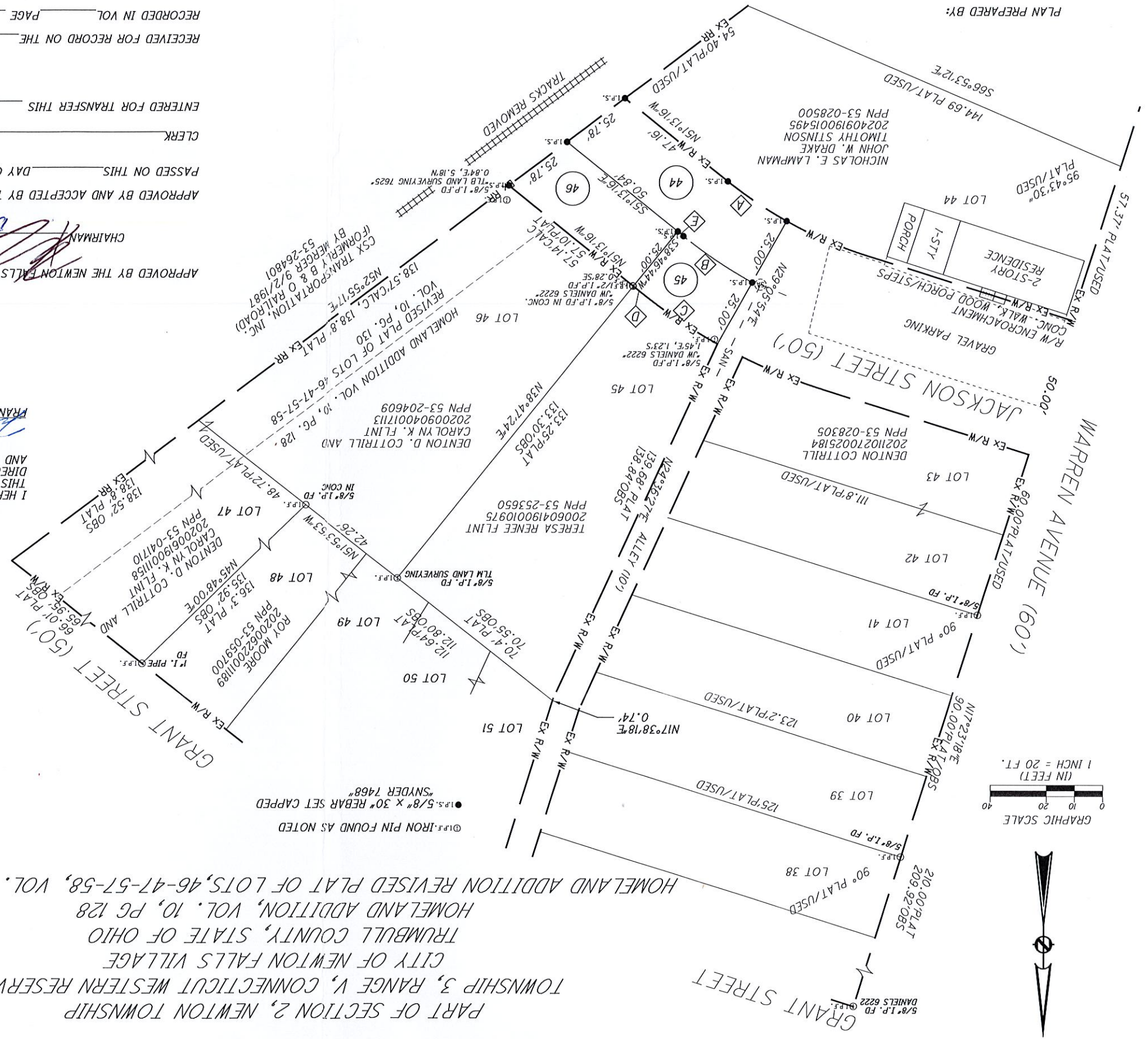

LINE AND CURVE TABLE

KEY	DELTA	RADIUS	ARC LENGTH	BEARING
A	09°40'51"	150.00'	25.34'	N56°03'41"W
B	09°40'51"	175.00'	29.57'	S56°03'41"E
C	09°40'51"	200.00'	33.79'	S56°03'41"E
D			2.62'	S51°13'16"E
Approved by Newton Falls Planning Commission				N51°13'16"W

Approved by *John M. Spellich*
Newton Falls Zoning Inspector

Signed *John M. Spellich*
Date *May 17 2025*

I HEREBY CERTIFY, TO THE BEST OF MY KNOWLEDGE AND BELIEF
THIS PLAT IS A TRUE DELINEATION OF A SURVEY MADE AT THE
DIRECTION OF NEWTON FALLS BY THOMAS FOK & ASSOCIATES, INC.
AND THAT ALL MONUMENTS SHOWN ARE IN PLACE.
FRANKLIN D. SNYDER, JR., P.S. NO. S-7468
DATE *11/27/2024*



VACATED RW AREAS =
PARCEL 44 = 0.044 AC. (1919 S.F.)
PARCEL 45 = 0.020 AC. (857 S.F.)
PARCEL 46 = 0.031 AC. (1349 S.F.)
TOTAL = 0.095 AC. (4125 S.F.)

APPROVED BY THE NEWTON FALLS PLANNING COMMISSION THIS *7* DAY OF *January* 2025
CHAIRMAN *John Snyder*
SECRETARY *Brian Kopp*

PASSED ON THIS _____ DAY OF _____, 2024,
CLERK _____
MAYOR _____
ENTERED FOR TRANSFER THIS _____ DAY OF _____ 2024
TRUMBULL COUNTY AUDITOR _____
RECEIVED FOR RECORD ON THE _____ DAY OF _____, 2024, AT _____ O'CLOCK
PAGE _____ OF THE TRUMBULL COUNTY RECORD OF PLATS
ON THE _____ DAY OF _____, 2024,
TRUMBULL COUNTY RECORDER _____

BASIS FOR BEARINGS:
ALL BEARINGS SHOWN ARE FOR PROJECT USE ONLY.
DEPARTMENT OF TRANSPORTATION, TRUMBULL COUNTY
COORDINATE SYSTEM BY GNSS RTN MEASUREMENTS IN
OCTOBER, 2024.

Description of Jackson Street Vacation Area 44

Situate in the State of Ohio, County of Trumbull, Village of the City of Newton Falls, in Section 2 of original Newton Township, Township 3, Range V of the Connecticut Western Reserve and being part of Jackson Street, 50.00 feet wide, as dedicated by the Homeland Addition plat recorded in volume 10, page 128 of the Trumbull County Recorder's Office and further described as follows:

Beginning at an iron pin set at the northeasterly corner of lot 44 of the Homeland Addition plat, also being the southeasterly limit of Jackson Street and the northwesterly line of the CSX Transportation, Inc. (formerly B & O Railroad) land;

Thence along the northerly line of lot 44 and the southerly right of way line of Jackson Street, **North 51 degrees, 13 minutes, 16 seconds West, 47.16 feet** to an iron pin set at a point of curvature;

Thence continuing along the northerly line of lot 44 and the southerly right of way line of Jackson Street, along the arc of a curve deflecting to the left, **25.34 feet** to an iron pin set where a line drawn normal to the southerly right of way line of Jackson Street, from the intersection of the northerly right of way line of Jackson Street with the easterly line of a 10.00 feet wide alley dedicated by the Homeland Addition plat at the southwesterly corner of lot 45, intersects the southerly right of way line of Jackson Street, said curve having a **radius 150.00 feet, a delta of 09 degrees, 40 minutes, 51 seconds, and a chord of 25.31 feet which bears North 56 degrees, 03 minutes, 41 seconds West;**

Thence along a line normal to the centerline of Jackson Street, **North 29 degrees, 05 minutes, 54 seconds East, 25.00 feet** to an iron pin set in the centerline of Jackson Street;

Thence along the centerline of Jackson Street, along the arc of a non-tangential curve deflecting to the right, **29.57 feet** to an iron pin set at a point of tangency, said curve having a **radius of 175.00 feet, a delta of 09 degrees, 40 minutes, 51 seconds, and a chord of 29.53 feet which bears South 56 degrees, 03 minutes, 41 seconds East;**

Thence continuing along the centerline of Jackson Street, **South 51 degrees, 13 minutes, 16 second East,** at 2.62 feet passing through an iron pin set, a total distance of **53.46 feet** to an iron pin set in the northwesterly line of the CSX Transportation Inc.'s land at the easterly limit of Jackson Street;

Thence along the easterly limit of Jackson Street and the northwesterly line of the CSX Transportation Inc.'s land, **South 52 minutes, 55 seconds, 17 seconds West, 25.78 feet** to the place of beginning and containing 0.044 acres (1919 S.F.) of land, more or less, as surveyed and described in November 2024 by Thomas Fok & Associates, Inc. under the supervision of Franklin D. Snyder, Jr., PS Ohio# S-7468.

Intending to describe that southerly portion of Jackson Street to be vacated which is located easterly of the 10.00 feet wide alley by a line extended normal to the southerly right of way line of Jackson Street and along northerly boundary of lot 44 of the Homeland Addition plat.

The bearings used herein are relative to grid north of the Ohio Department of Transportation, Trumbull County Coordinate System, with a bearing of North 38 degrees, 47 minutes, 24 seconds East along the line between lot 45 and lot 46 of the Homeland Addition plat. All iron pins described as set are 5/8-inch rebars set 30-inches deep with a yellow plastic cap embossed "SNYDER 7468".

Franklin D. Snyder, Jr. P.S.
11/27/2024



Deed Runner Printout

11-27-2024 13:47:47

FileName: C:\Program Files (x86)\DeedRunner 3 SL\Untitled.txt
 Grantor: AREA 44
 Grantee:
 Date: 11/27/24
 Deed Book:
 Page Number:
 County: TRUMBULL
 State:

Description

LINE NUM	BEARING	DISTANCE(FT)	RADIUS(FT)	ARC LENGTH(FT)
1	N 51°13'16" W	47.160	0.000	0.000
2	N 56°03'41" W	25.310	150.000	25.340
3	N 29°05'54" E	25.000	0.000	0.000
4	S 56°03'41" E	29.530	175.000	29.570
5	S 51°13'16" E	53.460	0.000	0.000
6	S 52°55'17" W	25.780	0.000	0.000

Closure: 0 Feet(0.001Meters)
 Precision: 1 : 79716.36
 Delta North: 0.000 Feet(0.000Meters)
 Delta East: -0.003 Feet(-0.001Meters)
 Error Bearing: N 85°27'49" W
 Chord Area: 0.0446 Acres (1940.81 Square Feet) (0.0178 Hectares)
 Perimeter: 206.31 Feet (62.883Meters)
 Total Area: 0.0441 Acres (1919.08 Square Feet) (0.0178 Hectares)

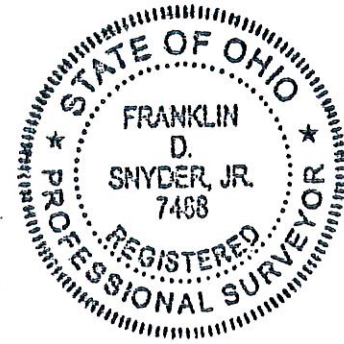

Franklin D. Snyder, Jr.
11/27/2024

Description of Jackson Street Vacation Area 45

Situate in the State of Ohio, County of Trumbull, Village of the City of Newton Falls, in Section 2 of original Newton Township, Township 3, Range V of the Connecticut Western Reserve and being part of Jackson Street, 50.00 feet wide, as dedicated by the Homeland Addition plat recoded in volume 10, page 128 of the Trumbull County Recorder's Office and further described as follows:

Beginning at the southwesterly corner of lot 45 of the Homeland Addition, also being the intersection of the northerly right of way line of Jackson Street with the easterly line of the 10.00 feet wide alley dedicated by the Homeland Addition plat, said point being referenced by a 5/8 inch iron pin found 1.45 feet east and 1.23 feet south, capped JW Daniels 6222;

Thence along the southerly line of lot 45, also being the northerly right of way line of Jackson Street and along the arc of a non-tangential curve deflecting to the right, **33.79 feet** to a point of tangency, said curve having a **radius of 200.00 feet, a delta of 09 degrees, 40 minutes, 51 seconds, and a chord of 33.75 feet which bears South 56 degrees, 03 minutes, 41 seconds East;**

Thence continuing along the southerly line of lot 45 and the northerly right of way line of Jackson Street, **South 51 degrees, 13 minutes, 16 seconds East, 2.62 feet** to a 5/8 inch iron pin found in concrete, capped JW Daniels 6222, at the southwesterly corner of lot 46, also being the southeasterly corner of lot 45, with a 1/2 inch iron pin found 0.28 feet southeast;

Thence normal to the centerline of Jackson Street, **South 38 degrees, 46 minutes, 44 seconds West, 25.00 feet** to an iron pin set on the centerline of Jackson Street;

Thence along the centerline of Jackson Street, **North 51 degrees, 13 minutes 16 seconds West, 2.62 feet** to an iron pin set at a point of curvature;

Thence along the arc of a curve deflecting to the left, **29.57 feet** to an iron pin set at the intersection with a line drawn normal to the centerline of Jackson Street, from the intersection of the northerly right of way line of Jackson Street with the easterly line of the 10.00 feet wide alley dedicated by the Homeland Addition plat, said curve having a **radius 175.00 feet, a delta of 09 degrees, 40 minutes, 51 seconds, and an chord of 29.53 feet which bears North 56 degrees, 03 minutes, 41 seconds West;**

Thence along a line normal to the northerly right of way line of Jackson Street, **North 29 degrees, 05 minutes, 54 seconds East, 25.00 feet** to the place of beginning and containing 0.020 acres (857 S.F.) of land, more or less, as surveyed and described in November 2024 by Thomas Fok & Associates, Inc. under the supervision of Franklin D. Snyder, Jr., PS Ohio# S-7468.

Intending to describe that northerly portion of Jackson Street to be vacated which is located easterly of the 10.00 feet wide alley and along the southerly boundary of lot 45 of the Homeland Addition plat.

The bearings used herein are relative to grid north of the Ohio Department of Transportation, Trumbull County Coordinate System, with a bearing of North 38 degrees, 47 minutes, 24 seconds East along the line between lot 45 and lot 46 of the Homeland Addition plat. All iron pins described as set are 5/8-inch rebars set 30-inches deep with a yellow plastic cap embossed "SNYDER 7468".

Franklin D. Snyder, Jr. P.S.
11/27/2024



Deed Runner Printout

11-27-2024 14:08:06

FileName: C:\Program Files (x86)\DeedRunner 3 SL\UNTITLED.TXT
 Grantor: AREA 45
 Grantee:
 Date: 11/27/24
 Deed Book:
 Page Number:
 County: TRUMBULL
 State:

Description

LINE NUM	BEARING	DISTANCE(FT)	RADIUS(FT)	ARC LENGTH(FT)
1	S 56°03'41" E	33.750	200.000	33.790
2	S 51°13'16" E	2.620	0.000	0.000
3	S 38°46'44" W	25.000	0.000	0.000
4	N 51°13'16" W	2.620	0.000	0.000
5	N 56°03'41" W	29.530	175.000	29.570
6	N 29°05'54" E	25.000	0.000	0.000

Closure: 0 Feet(0.000Meters)
 Precision: 1 : 109495.39
 Delta North: 0.001 Feet(0.000Meters)
 Delta East: -0.001 Feet(0.000Meters)
 Error Bearing: N 56°03'41" W
 Chord Area: 0.0196 Acres (853.68 Square Feet) (0.0080 Hectares)
 Perimeter: 118.60 Feet (36.149Meters)
 Total Area: 0.0197 Acres (857.00 Square Feet) (0.0080 Hectares)

Franklin D. Snyder, P.S.
 11/27/2024



Description of Jackson Street Vacation Area 46

Situate in the State of Ohio, County of Trumbull, Village of the City of Newton Falls, in Section 2 of original Newton Township, Township 3, Range V of the Connecticut Western Reserve and being part of Jackson Street, 50.00 feet wide, as dedicated in the Homeland Addition plat recorded in volume 10, page 128 of the Trumbull County Recorder's Office and further described as follows:

Beginning at an iron pin set at the southeasterly corner of lot 46 of the Revised Plat of Lots 46-47-57-58 and Alley Abutting Lots 46, 47, 57, 58 as recorded in volume 10, page 130 of the Trumbull County Recorder's Office, also being the southeasterly limit of Jackson Street as dedicated in the Homeland Addition plat and the northwesterly line of the CSX Transportation, Inc.'s (formerly B & O Railroad) land, witnessed by a 5/8 inch iron pin found, 1.2 feet tall, 0.84 feet east, 5.18 feet north, capped TLB Land Surveying 7625;

Thence along the easterly limit of Jackson Street and the northwesterly line of the CSX Transportation Inc.'s land, **South 52 minutes, 55 seconds, 17 seconds West, 25.78 feet** to an iron pin set at the centerline of Jackson Street;

Thence along the centerline of Jackson Street, **North 51 degrees, 13 minutes, 16 seconds West 50.84 feet** to an iron pin set;

Thence normal to the northerly right of way line of Jackson Street, **North 38 minutes, 46 seconds, 44 seconds East, 25.00 feet** to a 5/8 inch iron pin found in concrete, capped JW Daniels 6222, at the southeasterly corner of lot 45, also being the southwesterly corner of lot 46, with a 1/2 inch iron pin found 0.28 feet southeast;

Thence along the southerly line of lot 46, also being the northerly right of way line of Jackson Street, **South 51 degrees, 13 minutes, 16 seconds East, 57.14 feet** to the place of beginning and containing 0.020 acres (1349 S.F.) of land, more or less, as surveyed and described in November 2024 by Thomas Fok & Associates, Inc. under the supervision of Franklin D. Snyder, Jr., PS Ohio# S-7468.

Intending to describe that northerly portion of Jackson Street to be vacated which is along the southerly boundary of lot 46 of the Homeland Addition plat and the Revised Plat of Lots 46-47-57-58 and Alley Abutting Lots 46, 47, 57, 58.

The bearings used herein are relative to grid north of the Ohio Department of Transportation, Trumbull County Coordinate System, with a bearing of North 38 degrees, 47 minutes, 24 seconds East along the line between lot 45 and lot 46 of the Homeland Addition plat. All iron pins described as set are 5/8-inch rebars set 30-inches deep with a yellow plastic cap embossed "SNYDER 7468".

Franklin D. Snyder, Jr. P.S.
11/27/2024

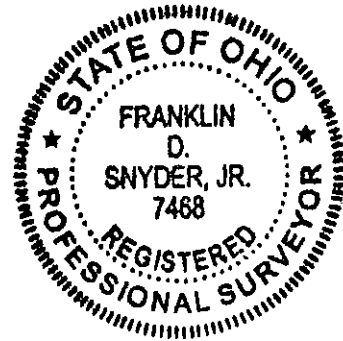

Deed Runner Printout

-27-2024 14:43:40

eName: C:\Program Files (x86)\DeedRunner 3 SL\Untitled.txt
 antor: AREA 46
 antee:
 ite: 11/27/24
 ed Book:
 ige Number:
 unty: TRUMBULL
 ate:

Description

VE NUM	BEARING	DISTANCE(FT)	RADIUS(FT)	ARC LENGTH(FT)
1	S 52°55'17" W	25.780	0.000	0.000
2	N 51°13'16" W	50.840	0.000	0.000
3	N 38°46'44" E	25.000	0.000	0.000
4	S 51°13'16" E	57.140	0.000	0.000

osure: 0 Feet(0.001Meters)
 ecision: 1 : 91861.20
 lta North: 0.000 Feet(0.000Meters)
 lta East: -0.002 Feet(-0.001Meters)
 or Bearing: S 76°36'58" W
 ord Area: 0.0310 Acres (1349.70 Square Feet) (0.0125 Hectares)
 rimeter: 158.76 Feet (48.390Meters)
 tal Area: 0.0310 Acres (1349.70 Square Feet) (0.0125 Hectares)

Franklin D. Snyder, Jr.
 11/27/2024



VILLAGE OF NEWTON FALLS, OHIO
ORDINANCE NO.: 2025-06
SPONSORS: Councilpersons Axiotis, Rufener

AN ORDINANCE AUTHORIZING THE INTERIM CITY MANAGER TO ENTER INTO AN AGREEMENT TO AMEND THE COMPENSATION PROVISIONS OF THE INVESTMENT MANAGEMENT AGREEMENT BETWEEN THE VILLAGE AND MEEDER PUBLIC FUNDS, INC.

WHEREAS, on or about December 21, 2021, The Village of Newton Falls (Village) and Meeder Public Funds, Inc. (Meeder) entered into an Investment Management Agreement (Exhibit A) in which Meeder committed to provide investment management services to the Village; and

WHEREAS, Meeder and the Village wish to amend the Agreement relating to the compensation provisions of the Investment Management Agreement.

NOW, THEREFORE, the Council of the Village of Newton Falls, State of Ohio, hereby ordains:

SECTION 1. That Council hereby authorizes the Interim City Manager to enter into the attached Amendment to the Investment Management Agreement (Exhibit B).

SECTION 2. That all formal actions of this Council concerning and relating to the adoption of this Ordinance were taken in an open meeting of this Council, and all deliberations of this Council or any of its committees that resulted in such formal action were taken in meetings open to the public and/or in compliance with all legal requirements, including Section 121.22 of the Ohio Revised Code.

SECTION 3. That this Ordinance shall be effective as of the earliest date permitted by law.

PASSED IN COUNCIL THIS _____ DAY OF MARCH, 2025

David Hanson, Mayor

Attest:

Michael Acomb, Clerk of Council

Approved as to Legal Form.

Jeff Limbian, Law Director

Investment Management Agreement

Meeder Public Funds

This Investment Management Agreement ("Agreement") is effective as of the date executed by and between Meeder Public Funds, Inc. ("Meeder"), its applicable affiliates, and the undersigned account owner ("Client").

1. **Investment Management Services.** Under this Agreement, Meeder provides discretionary investment management services for public entity clients in accordance with the terms of the applicable state investment code and investment policy.

2. **Appointment.** Client appoints Meeder as discretionary investment manager to manage the assets deposited in any account subject to the terms of this Agreement ("Account"). Meeder accepts the appointment as investment manager and shall invest, reinvest and manage the securities, cash and other assets of the Account subject to any Investment Policy Statement provided by Client. Meeder shall provide advice only with respect to assets in the Account and shall have no responsibility for the actions or non-actions of predecessor investment advisors or for the management of assets other than the assets allocated to the Account.

3. **Trading Authorization.** Client grants Meeder discretionary trading authority and appoints Meeder as agent and attorney-in-fact with respect to investments in the Account. Meeder may direct the purchase, sale, exchange, conversion, delivery or other acquisition or disposition of securities and other investments in the Account and act on behalf of Client in all other matters incidental to the handling of Account investments, all without prior consultation with Client.

4. **Custody.** Meeder will not assume physical custody of the Account or any portion of it. Client shall establish a custodial account with a qualified custodian ("Custodian"). Client will receive from the Custodian account statements and confirmations identifying assets and transactions in the Account. All transactions will be consummated by payment to, or delivery by, the Custodian of all cash, securities and other assets due to or from the Account. The Custodian shall be responsible for investing any daily cash balances in the Account and Meeder will not exercise discretion to select sweep vehicles for the Account.

5. **Investment Objectives and Restrictions.** Client may provide Meeder with an Investment Policy Statement or other written directions setting forth the investment objectives and any specific investment restrictions or limitations which govern the Account. Meeder shall be entitled to rely on such guidelines, objectives and restrictions relating to the Account as it may receive from Client. It is Client's responsibility to inform Meeder in writing of any changes or modifications to the Investment Guidelines, which shall be given ten days in advance of any such change.

6. **Brokerage.** Unless otherwise directed, Meeder will place trades for the Account through such brokers or dealers as it may select. When selecting brokers, Meeder's primary consideration will be the broker's ability to provide best execution of trades and Meeder may consider the quality and reliability of the brokerage services, trade price and commission, as well as research and other services provided by the broker-dealers.

7. **Trade Aggregation.** Meeder may aggregate trades for multiple clients when, in the adviser's judgment, aggregation is in the best interests of the clients involved. Orders are aggregated to facilitate best execution and allocate equitably among clients the effects of any market fluctuations that might have otherwise occurred had these orders been placed independently. Where it is not possible to obtain the same execution price for all securities purchased or sold on an aggregated basis, Meeder may allocate trades equitably among its clients using the average execution price.

8. **Fees.** For the services provided in accordance with this Agreement, Client will pay an investment advisory fee as indicated on Schedule A to this Agreement. Investment advisory fees do not include custody fees charged by Client's selected Custodian. Where Client has elected to have fees deducted, Client authorizes the Custodian to deduct fees from the Account and pay them to Meeder.

9. **Solicitor Arrangements.** Meeder accepts Clients referred through unaffiliated introducing advisors ("Solicitors") and Meeder Public Funds, Inc. may pay a referral fee directly or through its affiliate, Meeder Advisory Services, Inc., in connection with Client's Account. Each Client who is introduced to Meeder by a Solicitor will acknowledge the amount of the referral fee in a separate Written Disclosure Statement.

10. **Third-Party Payments.** Meeder or its affiliates receive compensation from unaffiliated third parties for opening, administering or advising certain financial products offered to advisory clients, including STAR Ohio and the Government Insured Deposit Program (GIDP). Asset based advisory fees are not charged for assets invested in products that pay indirect compensation to Meeder.

11. **Proxy Voting.** Meeder does not accept or assume authority to vote proxies for its public fund clients. Clients will receive their proxies or other solicitations directly from their Custodian. Client agrees that Meeder will not advise or act for Client in any legal proceedings, including bankruptcies or class actions, involving securities held or previously held by the Account or the issuers of such securities.

12. **Electronic Delivery.** Client consents to electronic delivery of all documents from Meeder, including but not limited to a copy of the executed Agreement, statements, confirmations, Meeder's Form ADV Part 2, and other general communications.

13. **Confidentiality.** All information and advice furnished by either party to the other, including their respective agents and employees, shall be treated as confidential and shall not be disclosed to third parties except as otherwise required by law or as agreed to in writing by Client. Notwithstanding the foregoing, Client consents to the use of Client's name in sales and marketing material used by Meeder or its affiliates solely for the purpose of identifying the Client as an investment advisory client.

14. **Services to Other Clients.** Client understands that Meeder serves as investment adviser for other clients and will continue to do so. Client also understands that Meeder, its personnel and affiliates ("Affiliated Persons") may give advice or take action in performing their duties to other clients, or for their own accounts, that differ from advice given to or action taken for Client. Meeder is not obligated to buy, sell or recommend for Client any security or other investment that Meeder or its Affiliated Persons may buy, sell or recommend for any other client or their own accounts.

15. **Meeder's Representations.** Meeder represents that it is a registered investment adviser under the Investment Advisers Act of 1940.

16. **Client's Representations.** Client represents and acknowledges that: (i) Client is the sole owner of the Account assets and has full power and authority to enter into this Agreement and to commit the assets to Meeder's management and supervision; (ii) that the person signing this Agreement on behalf of Client is authorized and empowered to establish accounts and commit the assets to Meeder's management and supervision on the entity's behalf; (iii) Client has received Meeder's current Form ADV, Part 2A and B; and (iv) Client has received a copy of Meeder's Privacy Policy.

17. **Term.** This Agreement may be terminated by either party for any or no reason upon delivery by first class U.S. mail, postage prepaid, or delivery by hand, of a written "Notice of Termination" to the other party at least thirty (30) days prior to the date of the intended early termination of this Agreement. Termination of this Agreement will not affect the status, obligations or liabilities of the parties to this Agreement that arose prior to such termination.

18. **Limitation of Liability.** Except for negligence, malfeasance or violation of applicable law, neither Meeder nor its officers, directors or employees shall be liable to Client for any action performed, or omitted to be performed, or for any errors of judgment in managing the Account. Nor shall Meeder be liable to Client for any act or failure to

act by any other third party. The federal securities laws impose liabilities under certain circumstances on persons even when they act in good faith. Therefore, nothing in this Agreement shall in any way constitute a waiver or limitation of any rights that Client may have under any federal or state securities laws.

19. **Assignment.** This Agreement may not be assigned by either party without the consent of the other party. Meeder will provide Client at least thirty (30) days prior written notice of any proposed assignment, and Client's consent will be presumed unless Client notifies Meeder otherwise in writing prior to the date of the assignment indicated on the notice.

20. **Amendment.** This Agreement may be amended by Meeder with thirty (30) days prior written notice to Client and may be amended immediately upon notice to the extent reasonably required to satisfy federal or state regulatory requirements.

21. **Governing Law.** This Agreement will be governed by and construed in accordance with the laws of the State of Ohio without giving effect to any conflict or choice of law provisions of that State.

22. **Severability.** If any provision of this Agreement is or should become inconsistent with any law or rule of any governmental or regulatory body having jurisdiction over the subject matter of this Agreement, the provision will be deemed to be rescinded or modified in accordance with any such law or rule. In all other respects, this Agreement will continue and remain in full force and effect.

23. **Affiliates.** To the extent necessary to carry out the terms of this Agreement, any named affiliate of Meeder shall be deemed to be a party to the Agreement for that purpose.

IN WITNESS WHEREOF, the parties have caused this Agreement to be executed by their duly authorized officers or agents to become effective as of the day and year first written above.

MEEDER PUBLIC FUNDS, Inc.

CITY OF NEWTON FALLS

Jason Headings

Sr. Vice President

TITLE

SIGNATURE

DATE

Jason Headings
12/22/21

TITLE

SIGNATURE

DATE

City Manager
James Sweeney
12/24/21



Meeder Public Funds

Schedule of Fees

Asset Based Fee

This schedule sets forth the standard annual investment advisory fee applicable to the Account under this Agreement. The schedule is tiered and each tier of assets under management will be assessed at the rate set forth in the schedule.

Operating Funds	
Assets Under Management	Annual Advisory Fee
Up to \$25,000,000	0.10%
\$25,000,000 - \$50,000,000	0.08%
\$50,000,000 - \$100,000,000	0.06%
Over \$100,000,000	0.04%

Project Funds	
Assets Under Management	Annual Advisory Fee
First \$50 million	0.06%
Over \$50 million	0.04%

Investment advisory fees are subject to minimum fee of \$5,000 per year. Fees are calculated and billed monthly in arrears based on the value of the securities, cash and other assets in the account at the end of the billing period. Unless otherwise agreed, fees are deducted directly from the Account. For clients who utilize Meeder's Preferred Custodian, fees may be credited an amount equal to the custodial fee up to a maximum annual credit of 0.01%. Meeder reserves the right to discontinue credits for custodial fees charged by the Preferred Custodian at any time and upon 30 days' notice in writing of the change to Client.



AMENDMENT TO INVESTMENT MANAGEMENT AGREEMENT

Meeder Public Funds

This Amendment to the Investment Management Agreement is effective as of May 1, 2025 (“Effective Date”), by and between City of Newton Falls (“Client”) and Meeder Public Funds, Inc. (“Meeder”).

WHEREAS, on or about December 21, 2021, Client and Meeder entered into an Investment Management Agreement (the “Agreement”) in which Meeder committed to provide investment management services to Client; and

WHEREAS, Meeder and Client wish to amend the Agreement relating to the compensation provisions of the Agreement.

NOW THEREFORE, in consideration of the mutual covenants, promises, conditions and terms to be kept and performed, Client and Meeder mutually agree as follows:

1. The fee schedule as indicated in the Fee section of the Agreement is amended to a minimum fee of \$7,500.
2. All other terms, conditions, and provisions of the Agreement shall remain in full force and effect; provided, however, that any other provision of the Agreement shall be deemed modified as necessary to give practical effect to the provisions of this Agreement.

IN WITNESS WHEREOF, the parties have caused this Agreement to be executed by their duly authorized officers or agents to become effective as of the Effective Date.

MEEDER PUBLIC FUNDS, INC.

CITY OF NEWTON FALLS

By: _____

By: _____

Name: _____

Name: _____

Title: _____

Title: _____

VILLAGE OF NEWTON FALLS, OHIO
ORDINANCE NO.: 2025-07
SPONSOR: Councilpersons: Stimpert, Rufener

AN ORDINANCE RATIFYING AND/OR CONFIRMING THE ADMINISTRATIVE OVERHEAD COST ALLOCATIONS TO THE ELECTRIC REVENUE FUND, THE WATER REVENUE FUND, THE SEWER REVENUE FUND AND GENERAL FUND.

WHEREAS, The Council of the Village of Newton Falls established a fair and equitable method for determining administrative support services for the Electric Revenue Fund, the Water Revenue Fund, the Sewer Revenue Fund and General Fund; and

WHEREAS, The Finance Director has followed the overhead cost allocation plan approved by Council to determine the allocations.

NOW, THEREFORE, the Council of the Village of Newton Falls, State of Ohio, hereby ordains:

SECTION 1: The method of determining administrative cost allocations has been approved by Council by way of Resolution 01-2025.

SECTION 2: Administrative overhead allocations will be to the following funds General Fund, Water Fund, Sewer Fund, and Electric Fund.

SECTION 3: Overhead cost allocations will be based on each previous year's statistical data, requiring an annual update of data.

SECTION 4: The percentages, which are presented in "Exhibit A" attached hereto as if fully rewritten herein, set by this methodology, are hereby approved by Council.

SECTION 5: The remainder of Ordinance 2007-22 shall remain intact.

SECTION 6: Any Ordinance or parts of ordinances in conflict with the context of this ordinance are hereby repealed.

SECTION 7: That all formal actions of this Council concerning and relating to the adoption of this Ordinance were taken in an open meeting of this Council, and all deliberations of this Council or any of its committees that resulted in such formal action were taken in meetings open to the public and/or in compliance with all legal requirements, including Section 121.22 of the Ohio Revised Code.

PASSED IN COUNCIL THIS _____ DAY OF _____, 2025

Attest:

David Hanson, Mayor

Michael Acomb, Clerk of Council

Approved as to Legal Form.

Jeff Limbian, Law Director

Exhibit A

City Manager			
	2025	2024	2023
General	23.14%	26.23%	34.86%
Water Plant	15.79%	14.30%	10.43%
Water Distribution	15.79%	14.30%	10.43%
Sewer	21.90%	18.58%	16.04%
Electric	23.38%	26.59%	28.25%
	100.0%	100.0%	100.0%
Council			
General	23.14%	26.23%	34.86%
Water Plant	15.79%	14.30%	10.43%
Water Distribution	15.79%	14.30%	10.43%
Sewer	21.90%	18.58%	16.04%
Electric	23.38%	26.59%	28.25%
	100.0%	100.0%	100.0%
Finance			
General	25.63%	20.93%	27.19%
Water Plant	12.76%	13.73%	12.67%
Water Distribution	12.76%	13.73%	12.67%
Sewer	19.19%	18.66%	13.43%
Electric	29.65%	32.96%	34.05%
	100.0%	100.0%	100.0%
Law			
General	23.29%	32.11%	40.18%
Water Plant	13.95%	14.23%	11.41%
Water Distribution	13.95%	14.23%	11.41%
Sewer	22.44%	19.66%	18.29%
Electric	26.37%	19.77%	18.70%
	100.0%	100.0%	100.0%

VILLAGE OF NEWTON FALLS, OHIO
ORDINANCE NO: 2025-08
SPONSORS: Councilpersons Stimpert, Rufener

AN ORDINANCE AMENDING NEWTON FALLS HYDRANT BULK WATER RATES EFFECTIVE MAY 1, 2025 FOR THE YEARS 2025 THROUGH 2026 AND THAT THE HYDRANT WATER RATES ARE INSTITUTED WITH THE FIRE HYDRANT USAGE METERING POLICY ATTACHED AS EXHIBIT A.

WHEREAS, the Village of Newton Falls retained Arcadis Design & Consultancy (hereinafter "Arcadis") in 2020 to perform a Water Rate Study and provide Water Rate recommendations for each year commencing in 2022; and

WHEREAS, Arcadis performed the requested rate study in 2021 and made recommendations for Rate Amendments for years 2022 through 2026; and

WHEREAS, based upon the Arcadis study, the Village desires to amend the Hydrant Rate for BULK WATER SALES in conformity with Arcadis recommendations effective May 1, 2025 for the years 2025 through 2026; and

WHEREAS, the Finance Director recommends that the Hydrant BULK WATER Rate Amendments are enacted with the Fire Hydrant Water Metering Policy attached Exhibit "A".

NOW THEREFORE, Council of the Village of Newton Falls, State of Ohio, hereby ordains:

SECTION 1: That the Council hereby and herein amends the Hydrant BULK WATER Rates, effective May 1, 2025 for the years 2025 through 2026 to reflect the rates established within the attached Fire Hydrant Water Metering Policy.

SECTION 2: That all formal actions of this Council concerning and relating to the adoption of this Ordinance were taken in an open meeting of this Council, and all deliberations of this Council or any of its committees that resulted in such formal action were taken in meetings open to the public and/or in compliance with all legal requirements, including Section 121.22 of the Ohio Revised Code.

SECTION 3: That this Ordinance shall be effective as of the earliest date permitted by law.

PASSED IN COUNCIL THIS ____ DAY OF _____, 2025

David Hanson, Mayor

Attest _____
Michael Acomb, Clerk of Council

Approved as to Legal Form _____
Jeff Limbian, Law Director



NEWTON FALLS, OHIO

Fire Hydrant Usage Water Rate Policy

Fees for 1" Fire Hydrant Metering

1. There will be a \$800 deposit for the equipment necessary to meter the Fire Hydrant.
2. There will be a \$100 set-up fee which includes the following:
 - a. Installation of the meter and backflow device
 - b. Initiating Fire Hydrant operation
 - c. Testing of the backflow device
 - d. Removal of the unit when use is no longer necessary
3. There will be a charge of \$12.64 per one thousand gallons of water used from the Hydrant

Restrictions for 1" Fire Hydrants

1. Fire Hydrants cannot be used when the outside temperature is below 35 degrees
2. An application must be completed at the Newton Falls Utility Office. Fire Hydrant meters availability will be based on completion of the application and payment of deposit.

Responsibilities of the Renter

1. The renter is responsible for the security deposit of the meter unit and backflow device
2. The renter must always use the outlet valve of the backflow device; Fire Hydrant and backflow device must always remain on. If the backflow device is inadvertently shut off, the renter must contact the City of Newton Falls Water Distribution Department immediately at 330-872-5656 so that the backflow device can be re-tested and reactivated
3. The renter must supply a connection apparatus and supply line to the outlet valve of the backflow device.
4. Fire Hydrant is to be operated ONLY by a qualified Newton Falls Water Department Employee and never by the renter
5. Failure to comply with all of these rules will result in the immediate removal of the Fire Hydrant meter, loss of the deposit, and the renter will forfeit the right to future use the device.

Renter _____ Date _____

City of Newton Falls _____ Date _____

VILLAGE OF NEWTON FALLS, OHIO
ORDINANCE NO.: 2025-09
SPONSOR: Councilpersons Stimpert, Rufener

AN ORDINANCE AUTHORIZING THE INTERIM CITY MANAGER TO ENTER INTO AN AGREEMENT WITH NATIONAL PUMP & PROCESS INC. TO REMOVE, REPAIR, AND REINSTALL A HIGH SERVICE PUMP FOR THE NEWTON FALLS WATER PLANT

WHEREAS, the existing high service pump at the Water Plant is in need of repairs; and

WHEREAS, the Water Department Superintendent and Interim City Manager investigated and received options for the removal, repair, and reinstallation services of the existing high service pump; and

WHEREAS, pursuant to Ohio Revised Code Section 9.17, formal advertisement and bidding are not required as the purchase is less than \$75,000; and

WHEREAS, Village Council desires to accept the quotation (Exhibit A) from National Pump & Process Inc. located at 180 Treat Road, Aurora, OH 44202., for the removal, repair, and reinstallation services of the existing high service pump as it was determined by the Interim City Manager to be the most cost-effective corrective measure and the lowest and best price for the project; and

WHEREAS, adequate funds for such a request are available for use in 2025.

NOW, THEREFORE, the Council of the Village of Newton Falls, State of Ohio, hereby ordains:

SECTION 1. That Council hereby and herein authorizes the Interim City Manager to enter into an agreement with National Pump & Process Inc. located at 180 Treat Road, Aurora, OH 44202, to remove, repair, and reinstall the existing high service pump for \$16,519.00 as set forth in the attached quotations (Exhibits A).

SECTION 2. That all formal actions of this Council concerning and relating to the adoption of this Ordinance was taken in an open meeting of this Council, and all deliberations of this Council or any of its committees that resulted in such formal action were taken in meetings open to the public and/or in compliance with all legal requirements, including Section 121.22 of the Ohio Revised Code.

SECTION 3. That this Ordinance shall be effective as of the earliest date permitted by law.

ORDINANCE NO.: 2025-09
PAGE 2

PASSED IN COUNCIL THIS _____ DAY OF _____, 2025.

David Hanson, Mayor

Attest:

Michael Acomb, Clerk of Council



Approved as to Legal Form.

Jeff Limbian, Law Director

 NATIONAL PUMP & PROCESS INC.	National Pump & Process 180 Treat Rd Aurora, OH, 44020 Phone: (330) 562-0220	Quote #: 18948 Goulds High Service Pump Model 3410 SN: No Tag
--	--	--

Cody Zeleny City of Newton Falls WTP 175 W. River Road Newton Falls, OH, 44444	Phone: (330) 872-1808 Mobile: 330-719-2175 Email: Waterplant@ci.newtonfalls.oh.us	Date: 17 February 2025 Rep.: Matt Glova Mobile: (216)-316-3097
--	---	--

Qty	Item #	Name	Price	Total
1	HS PMP	In Shop Pump Repair All labor and material to perform the following to one split case pump. ~ Transport to and from customer service. ~ Complete disassembly and inspection ~ Blasting & cleaning of all required components ~ Restore shaft sleeve surfaces and bearing housing ID's to proper dimensions ~ Replace all bearings and oil seals ~ Supply and install new TRICO Oilers & Oil Cups ~ Supply new complete coupling assembly ~ Supply new NSF Certified Suction and Discharge expansion joints. ~ Dynamically balance rotor assembly ~ Assemble, pressure test, and epoxy coat exterior Quote Does Not Include Re installation <div style="text-align: right; color: blue; font-family: cursive;"> OK 2-18-25 mh </div>	\$14,235.00	\$14,235.00
		Sub Total		\$14,235.00
		Shipping & Handling		
		Taxes	0.000%	\$.00
			TOTAL	\$14,235.00

BALDOR	 <small>ARKAL FILMAT AVIAD PEP</small>	 <small>SUMMIT PUMPS</small>	
--------	--	--	---

Thank you for your business

 <p>NATIONAL PUMP & PROCESS INC.</p>	<p>National Pump & Process 180 Treat Rd Aurora, OH, 44020 Phone: (330) 562-0220</p>	<p>Quote #: 2502008 Goulds High Service Pump Install</p>
--	---	--

<p>Cody Zeleny City of Newton Falls WTP 175 W. River Road Newton Falls, OH, 44444</p>	<p>Phone: (330) 872-1808 Mobile: 330-719-2175 Email: Waterplant@ci.newtonfalls.oh.us</p>	<p>Date: 18 February 2025 Rep.: Matt Glova Mobile: (216)-316-3097</p>
---	--	---

Qty	Item #	Name	Price	Total
1	HS INSTALL	Field Service All labor and material to perform the following Field Install All labor and material to perform the following install ~Transport completed repair to the plant ~Lower plant into basement with crane support from customer ~Install new motor coupling hub ~Mount pump onto base ~Install new suction and discharge expansion joints and connect to plant piping ~Perform final laser alignment to existing motor ~Finish coupling assembly ~Support pump start up	\$2,284.00	\$2,284.00
Sub Total				\$2,284.00
Shipping & Handling				
Taxes			0.000%	\$.00
TOTAL				\$2,284.00



Thank you for your business

VILLAGE OF NEWTON FALLS, OHIO
ORDINANCE NO.: 2025-10
SPONSOR: Councilpersons Stimpert, Rufener

AN ORDINANCE AUTHORIZING INTERIM CITY MANAGER TO ENTER INTO AN AGREEMENT TO PURCHASE A 2025 FORD F-350 FROM SARCHIONE FORD LINCOLN AND UPFITTING THE TRUCK WITH A SERVICE BODY FROM QUALITY TRUCK BODY FOR USE BY THE WATER DISTRIBUTION DEPARTMENT

WHEREAS, in order to properly serve the Village residents and property owners, the Water Distribution Department desires to purchase a new truck to replace a 22-year-old truck that is currently serving as one of the Department's vehicles; and

WHEREAS, the Maintenance Department Supervisor and Interim City Manager investigated options for purchasing a new upfitted truck; and

WHEREAS, pursuant to Ohio Revised Code Section 9.17, formal advertisement and bidding are not required if a purchase is for less than \$75,000; and

WHEREAS, Village Council desires to take advantage of the quote provided by Sarchione Ford Lincoln of Alliance, Ohio because the price of the truck is less than \$75,000, and also less than the price for a similar truck under the State's Cooperative Purchasing Program, and also has been determined by the Interim City Manager to be the most beneficial price for the purchase of a new 2025 Ford F-350 truck; and

WHEREAS, Village Council intends to also upfit the new 2025 Ford F-350 truck with a Hughes Aluminum Service Body by Quality Truck Body of Youngstown, Ohio; and

WHEREAS, Village Council intends to finance the purchase of the new 2025 Ford F-350 Truck with all upfitted equipment through Ford Credit Municipal Finance for a term of 5 years; and

WHEREAS, Council has approved these expenditures in the Village's 2025 Budget.

NOW, THEREFORE, the Council of the Village of Newton Falls, State of Ohio, hereby ordains:

SECTION 1. That Council hereby and herein authorizes the Interim City Manager to enter into an agreement to purchase a new 2025 Ford F-350 truck from Sarchione Ford Lincoln of Alliance, Ohio for \$59,396.00 as set forth in the attached quotation;

SECTION 2. The Council also hereby and herein authorizes the Interim City Manager to enter into an agreement to have the same, new 2025 Ford F-350 truck from Sarchione Ford Lincoln of Alliance, Ohio upfitted with a Hughes Aluminum Service Body by Quality Truck Body of Youngstown, as set forth in the attached quotation, for a separate and total amount of \$21,372.40, pursuant to the State of Ohio Department of Transportation specifications.

SECTION 3. The Council also hereby and herein authorizes the Interim City Manager to enter into an agreement with Ford Credit Municipal Financing to have the same, new 2025 Ford F-350 truck from Sarchione Ford Lincoln of Alliance, Ohio upfitted with a Hughes Aluminum Service Body by Quality Truck Body of Youngstown, financed for a term of 5 years as set forth in the attached quotation, with an annual payment of \$18,853.69

SECTION 4. That all formal actions of this Council concerning and relating to the adoption of this Ordinance were taken in an open meeting of this Council, and all deliberations of this Council or any of its committees that resulted in such formal action were taken in meetings open to the public and/or in compliance with all legal requirements, including Section 121.22 of the Ohio Revised Code.

SECTION 4. That this Ordinance shall be effective as of the earliest date permitted by law.

PASSED IN COUNCIL THIS _____ DAY OF _____, 2025.

David Hanson, Mayor

Attest:

Michael Acomb, Clerk of Council

Approved as to Legal Form.

Jeff Limbian, Law Director



Quality Truck Body
4440 Simon Road
Youngstown OH 44512

Phone: (330) 788-7087

Fax: (330) 788-9850

www.qualitytruckbody.com

QUOTE

Quote ID: Q11673

Quote Date: 1/29/2025

Quote Valid Until: 2/28/2025

Page 1 of 2

Customer: 99898

CITY OF NEWTON FALLS
WATER DISTRIBUTION DEPT.
135 WEST RIVER RD.

NEWTON FALLS, OH 44444

Contact: KEN

Phone: (330) 647-7675

Fax:

Salesperson: (None)

CUSTOMER VEHICLE INFO.:

2025 FORD F-350, 4x4, CREW CAB, GAS ENGINE, UPFITTER SWITCHES
CAB AND CHASSIS 60" CA

MANUFACTURER: HUGHES

MODEL: 9' x 96" ALUMINUM SERVICE BODY.

OVERALL DIMENSIONS: 96" WIDE x 108" LONG x 40" HIGH SIDE COMPARTMENTS
52" WIDE LOAD SPACE AND 16" DEEP SIDE COMPARTMENTS.

COMPARTMENT SIZE(S): FRONT VERTICALS 18"WIDE x 40" HIGH.
HORIZONTAL (OVER REAR WHEEL) 44" WIDE x 18" HIGH.
REAR VERTICALS 21" WIDE x 40' HIGH.

CONSTRUCTION: ALL ALUMINUM CONSTRUCTION - 1" EXTRUDED ALUMINUM
LOADSPACE FLOOR, 3" STRUCTURAL ALUMINUM CHANNEL
CROSSMEMBERS, 1/2" THICK REINFORCED MOUNTING POINTS,
1/8" BODY PANELS, 1/8" FENDER PANEL WITH 1-2/2" ROLLED
FENDER FLARE, REAR TAILSKIRT, 1/8" DOUBLE PANEL DOORS
AND 1/8" DOUBLE-WALL TAILGATE.
STAINLESS STEEL DOOR HINGES, STAINLESS STEEL "D"-HANDLE
ROLLER COMPRESSION DOOR LATCHES, GAS-STRUT VERTICAL
DOOR HOLDERS, CLIP-ON AUTOMOTIVE-STYLE BULB RUBBER DOOR
SEALS, SLAM LATCH PICK-UP STYLE TAILGATE LATCH, LED
FMVSS GROMMET MOUNTED BODY LIGHTING.

SHELF PKG.: (2) TWO, ADJUSTABLE SHELVES IN EACH FRONT VERTICAL
CABINETS.
(2) TWO, ADJUSTABLE SHELVES IN EACH REAR VERTICAL
CABINETS.
HORIZONTAL CABINETS ARE OPEN.

BUMPER: TREAD-BRITE ALUMINUM AN INTEGRAL PART OF THE REAR
BODY TAIL-SKIRT (SPLIT FOR RECEIVER HITCH.)

COMPARTMENT LIGHTS: L.E.D. LIGHT STRIPS INSTALLED IN COMPARTMENTS TIED TO UPFITTER SWIT

STROBE LIGHTS: SIX SURFACE-MOUNTED AMER/GREEN L.E.D.

HITCH: CLASS V RECEIVER HITCH WITH 7-WAY TRAILER WIRING.

COLOR: BODY PRIMED AND FINISHED PAINTED SINGLE STAGE FORD RED.
FORD FIRE RED

BACK-UP ALARM: INSTALLED.



Quality Truck Body
4440 Simon Road
Youngstown OH 44512

Phone: (330) 788-7087

Fax: (330) 788-9850

www.qualitytruckbody.com

QUOTE

Quote ID: Q11673

Quote Date: 1/29/2025

Quote Valid Until: 2/28/2025

Page 2 of 2

INSTALLATION: COMPLETE AND READY FOR OPERATION.

AS OF 01/29/2025 APPROX. 8-9 WEEK LEAD-TIME TO PRODUCE.

THANK YOU FOR YOUR CONSIDERATION!

Sub Total:	\$21,372.40
Discount:	\$0.00
Sales Tax:	\$0.00
Grand Total:	\$21,372.40

Customer must fill out the information below before the order can be processed...

Accepted by:	
Date:	
P.O. Number:	

* Terms are Due Upon Receipt unless prior credit arrangements are made at the time of order.

* Please note if chassis is furnished, it is as a convenience and terms are Net Due on Receipt of Chassis.

*Effective 8/1/2022, there will be a 3% surcharge on the total amount for all credit card transactions.

Prepared for: , CITY OF NEWTON FALLS

2025 F-350 Chassis 4x4 SD Crew Cab 179" WB SRW XL (W3F)

Price Level: 520



Client Proposal

Prepared by:

GREG BEULE

Office: 330-774-5966

Email: GBEULE@SARCHIONE.COM

Quote ID: newton2

Date: 02/11/2025



Sarchione Ford of Alliance | 2480 West State Street, Alliance, Ohio, 446013592
Office: 330-823-1128 | Fax: 330-829-1517

Prepared for:

CITY OF NEWTON FALLS

Prepared by: GREG BEULE

02/11/2025

Sarchione Ford of Alliance | 2480 West State Street Alliance Ohio | 446013592



2025 F-350 Chassis 4x4 SD Crew Cab 179" WB SRW XL (W3F)

Price Level: 520 | Quote ID: newton2

, **CITY OF NEWTON FALLS**

Re: Quote ID newton2 02/11/2025

To Whom It May Concern,

Thank you very much for your interest in acquiring a vehicle from our dealership. We concur that your interest is well deserved. We hope that an outstanding product lineup and our dedication to customer service will enhance your ownership experience should you decide to buy a vehicle from us.

Attached, please find additional information that I hope will assist you in making a more informed decision. Please feel free to contact me at any time as I would truly appreciate the opportunity to be of service to you.

Sincerely,

GREG BEULE

COMMERCIAL MGR.

330-774-5966

GBEULE@SARCHIONE.COM

Prices and content availability as shown are subject to change and should be treated as estimates only. Actual base vehicle, package and option pricing may vary from this estimate because of special local pricing, availability or pricing adjustments not reflected in the dealer's computer system. See salesperson for the most current information.

Prepared for:

CITY OF NEWTON FALLS

Prepared by: GREG BEULE

02/11/2025



Sarchione Ford of Alliance | 2480 West State Street Alliance Ohio | 446013592

2025 F-350 Chassis 4x4 SD Crew Cab 179" WB SRW XL (W3F)

Price Level: 520 | Quote ID: newton2

Table of Contents

Description	Page
Cover Page	1
Cover Letter	2
Table of Contents	3
As Configured Vehicle	4
Warranty	7
Pricing Summary - Single Vehicle	8

Prepared for:
 CITY OF NEWTON FALLS
 Prepared by: GREG BEULE
 02/11/2025



Sarchione Ford of Alliance | 2480 West State Street Alliance Ohio | 446013592

2025 F-350 Chassis 4x4 SD Crew Cab 179" WB SRW XL (W3F)

Price Level: 520 | Quote ID: newton2

As Configured Vehicle

Code	Description	MSRP
Base Vehicle		
W3F	Base Vehicle Price (W3F)	\$56,515.00
Packages		
630A	Order Code 630A <i>Includes:</i> - Engine: 7.3L 2V DEVCT NA PFI V8 Gas - Transmission: TorqShift 10-Speed Automatic 10R140 with neutral idle. Includes SelectShift and selectable drive modes: normal, tow/haul, eco, slippery roads and off-road. - Electronic-Locking w/4.30 Axle Ratio - GVWR: 11,400 lb Payload Package - Wheels: 18" Argent Painted Steel Includes painted hub covers/center ornaments. - HD Vinyl 40/20/40 Split Bench Seat Includes center armrest, cupholder, storage, 2-way adjustable driver/passenger headrests and driver's side manual lumbar. - Radio: AM/FM Stereo w/MP3 Player Includes 6 speakers. - SYNC 4 Communication & Entertainment System Includes enhanced voice recognition, 911 Assist, 8" LCD center stack screen, AppLink and 1 smart-charging USB port.	N/C
Powertrain		
99N	Engine: 7.3L 2V DEVCT NA PFI V8 Gas	Included
44G	Transmission: TorqShift 10-Speed Automatic 10R140 with neutral idle. Includes SelectShift and selectable drive modes: normal, tow/haul, eco, slippery roads and off-road.	Included
X4M	Electronic-Locking w/4.30 Axle Ratio	Included
STDGV	GVWR: 11,400 lb Payload Package Complete restrictions/requirements not available.	Included
Wheels & Tires		
TDX	Tires: LT275/70R18E BSW AT Spare may not be the same as road tire.	\$265.00
64F	Wheels: 18" Argent Painted Steel Includes painted hub covers/center ornaments.	Included
Seats & Seat Trim		

Prices and content availability as shown are subject to change and should be treated as estimates only. Actual base vehicle, package and option pricing may vary from this estimate because of special local pricing, availability or pricing adjustments not reflected in the dealer's computer system. See salesperson for the most current information.

Prepared for:

CITY OF NEWTON FALLS

Prepared by: GREG BEULE

02/11/2025

Sarchione Ford of Alliance | 2480 West State Street Alliance Ohio | 446013592

**2025 F-350 Chassis 4x4 SD Crew Cab 179" WB SRW XL (W3F)**

Price Level: 520 | Quote ID: newton2

As Configured Vehicle (cont'd)

Code	Description	MSRP
A	HD Vinyl 40/20/40 Split Bench Seat <i>Includes center armrest, cupholder, storage, 2-way adjustable driver/passenger headrests and driver's side manual lumbar.</i>	Included

Other Options

PAINT	Monotone Paint Application	STD
179WB	179" Wheelbase	STD
STDRD	Radio: AM/FM Stereo w/MP3 Player <i>Includes 6 speakers.</i> <i>Includes:</i> - SYNC 4 Communication & Entertainment System <i>Includes enhanced voice recognition, 911 Assist, 8" LCD center stack screen, AppLink and 1 smart-charging USB port.</i>	Included
473	Snow Plow Prep Package <i>Includes pre-selected springs (see order guide supplemental reference for springs/FGAWR of specific vehicle configurations). Note 1: Restrictions apply; see supplemental reference or body builders layout book for details. Note 2: Also allows for the attachment of a winch. Note 3: Highly recommended to add (86M) dual battery on 7.3L gas engine. Adding (67B) 410 amp dual alternators for diesel engine is highly recommended for max power output.</i>	\$250.00
41P	Transfer Case Skid Plates	\$100.00
86M	Dual 68 AH/65 AGM Battery	\$210.00
67B	410 Amp Dual Alternators <i>Includes 250 Amp + 160 Amp.</i>	\$115.00
18B	Platform Running Boards	\$445.00
59H	Center High-Mounted Stop Lamp (CHMSL)	N/C
872	Rear View Camera & Prep Kit <i>Pre-installed content includes cab wiring and frame wiring to the rear most cross member. Upfitters kit includes camera with mounting bracket, 20' jumper wire and camera mounting/aiming instructions.</i>	\$415.00
52B	Trailer Brake Controller	\$300.00
76C	Exterior Backup Alarm (Pre-Installed)	\$220.00

Fleet Options

WARANT	Fleet Customer Powertrain Limited Warranty Requires valid FIN code.	N/C
--------	--	-----

Prices and content availability as shown are subject to change and should be treated as estimates only. Actual base vehicle, package and option pricing may vary from this estimate because of special local pricing, availability or pricing adjustments not reflected in the dealer's computer system. See salesperson for the most current information.

Prepared for:

CITY OF NEWTON FALLS

Prepared by: GREG BEULE

02/11/2025

Sarchione Ford of Alliance | 2480 West State Street Alliance Ohio | 446013592



2025 F-350 Chassis 4x4 SD Crew Cab 179" WB SRW XL (W3F)

Price Level: 520 | Quote ID: newton2

As Configured Vehicle (cont'd)

Code	Description	MSRP
<p><i>Ford is increasing the 5-year 60,000-mile limited powertrain warranty to 5-years, 100,000 miles. Only Fleet purchasers with a valid Fleet Identification Number (FIN code) will receive the extended warranty. When the sale is entered into the sales reporting system with a sales type fleet along with a valid FIN code, the warranty extension will automatically be added to the vehicle. The extension will stay with the vehicle even if it is subsequently sold to a non-fleet customer before the expiration. This extension applies to both gas and diesel powertrains. Dealers can check for the warranty extension on eligible fleet vehicles in OASIS. Please refer to the Warranty and Policy Manual section 3.13.00 Gas Engine Commercial Warranty. This change will also be reflected in the printed Warranty Guided distributed with the purchase of every new vehicle.</i></p>		
Emissions		
425	50-State Emissions System	STD
Exterior Color		
PQ_01	Race Red	N/C
Interior Color		
AS_03	Medium Dark Slate w/HD Vinyl 40/20/40 Split Bench Seat	N/C
SUBTOTAL		\$58,835.00
Destination Charge		\$1,995.00
TOTAL		\$60,830.00

Prices and content availability as shown are subject to change and should be treated as estimates only. Actual base vehicle, package and option pricing may vary from this estimate because of special local pricing, availability or pricing adjustments not reflected in the dealer's computer system. See salesperson for the most current information.

Prepared for:

CITY OF NEWTON FALLS

Prepared by: GREG BEULE

02/11/2025



Sarchione Ford of Alliance | 2480 West State Street Alliance Ohio | 446013592

2025 F-350 Chassis 4x4 SD Crew Cab 179" WB SRW XL (W3F)

Price Level: 520 | Quote ID: newton2

Warranty

Standard Warranty

Basic Warranty

Basic warranty 36 months/36,000 miles

Powertrain Warranty

Powertrain warranty 60 months/60,000 miles

Corrosion Perforation

Corrosion perforation warranty 60 months/unlimited

Roadside Assistance Warranty

Roadside warranty 60 months/60,000 miles

Prices and content availability as shown are subject to change and should be treated as estimates only. Actual base vehicle, package and option pricing may vary from this estimate because of special local pricing, availability or pricing adjustments not reflected in the dealer's computer system. See salesperson for the most current information.

Prepared for:

CITY OF NEWTON FALLS

Prepared by: GREG BEULE

02/11/2025



Sarchione Ford of Alliance | 2480 West State Street Alliance Ohio | 446013592

2025 F-350 Chassis 4x4 SD Crew Cab 179" WB SRW XL (W3F)

Price Level: 520 | Quote ID: newton2

Pricing Summary - Single Vehicle

	MSRP
<i>Vehicle Pricing</i>	
Base Vehicle Price	\$56,515.00
Options	\$2,320.00
Colors	\$0.00
Upfitting	\$0.00
Fleet Discount	\$0.00
Fuel Charge	\$0.00
Destination Charge	\$1,995.00
Subtotal	\$60,830.00
<i>Discount Adjustments</i>	
Discount Adjustments	-\$1,856.00
Subtotal	\$58,974.00
<i>Post-Tax Adjustments</i>	
Code	MSRP
3	\$422.00
Description	
doc/ title/ lic fees	
Subtotal	\$59,396.00
Total	\$59,396.00

Customer Signature

Acceptance Date

Prices and content availability as shown are subject to change and should be treated as estimates only. Actual base vehicle, package and option pricing may vary from this estimate because of special local pricing, availability or pricing adjustments not reflected in the dealer's computer system. See salesperson for the most current information.

Financing Quote # 104596

February 13, 2025

Municipality: City of Newton Falls
Dealer: Sarchione Ford of Alliance

Ford Credit Municipal Finance is pleased to provide the following quote for your consideration.
Expiration Date: 4/14/2025

Description	Unit Price
2025 Ford F-350 w/ith 9' Hughes Aluminum Service Body	\$80,768.40

Total Asset Cost	\$80,768.40
Underwriting Fee	\$545.00
Amount Financed	\$81,313.40
Number of Payments	5
Payment Timing	Annual
Rate	7.99%
Payment Amount	\$18,853.69

This quote was prepared assuming the lease qualifies for Federal Income Tax Status for Ford Credit Company LLC under Section 103 of the IRS Code and is not a commitment by Ford Credit Municipal Finance. Financing is subject to credit review.

Thank you for the opportunity to provide this quote. If you have any questions, need additional options, or would like to proceed with the application process, please contact by using the information below.

Sincerely,

Janet Doty

Janet Doty
Marketing Coordinator
jdoty@ford.com
1-800-241-4199, press 1