



NEWTON FALLS CITY COUNCIL  
**REGULAR MEETING AGENDA**  
 Wednesday, February 19, 2025; 6:00 PM  
 COUNCIL CHAMBERS  
 612 WEST BROAD STREET

CITY COUNCIL MEMBERS	
Ward 1	Patricia Benetis
Ward 2	Brian Axiotis
Ward 3	VACANT
Ward 4	Kevin Rufener
At- Large	Julie Stimpert
Mayor	David Hanson

CITY ADMINISTRATION	
Interim City Manager	Mike Novotny
Law Director	Jeff Limbian
Finance Director	Jamie Vernaccini
Clerk of Council	Michael Acomb

- I. Call to Order**
- II. Pledge of Allegiance / Silent Prayer**
- III. Roll Call**
- IV. Changes To Tonight's Agenda**
- V. Special Presentations by Staff Members or Invited Consultants**
- VI. Public Comments (Agenda Items Only)**
- VII. Reports**
  - a. Mayor
  - b. Council Members
  - c. Law Director
  - d. Finance Director
  - e. City Manager
- VIII. Approval of Previous Minutes**  
 Regular Meeting Minutes February 5, 2025
- IX. Public Hearings**
- X. Unfinished Business**
- XI. New Business**
  - RESOLUTION 01-2025 *Sponsors: Councilpersons Benetis, Rufener*  
 A RESOLUTION REVISING THE METHODOLOGY USED TO DETERMINE ADMINISTRATIVE OVERHEAD COST ALLOCATIONS IN ORDER TO ASSIGN THE SHARED COST OF AN ITEM OR SERVICE TO THE GENERAL FUND, THE WATER REVENUE FUND, THE SEWER REVENUE FUND AND THE ELECTRIC REVENUE FUND OF VILLAGE OF NEWTON FALLS TO ENSURE THAT COSTS ARE SHARED EQUITABLY ACROSS THESE FUNDING SOURCES.
  
  - ORDINANCE 2025-02 *Sponsors: Councilpersons Rufener, Stimpert*  
 AN EMERGENCY ORDINANCE APPROVING THE RECODIFICATION, EDITING, AND INCLUSION OF CERTAIN ORDINANCES AS PARTS OF THE VARIOUS CODES OF THE CODIFIED ORDINANCES OF NEWTON FALLS, OHIO

ORDINANCE 2025-03 *Sponsors: Councilpersons Axiotis, Rufener*  
AN ORDINANCE REZONING THE PROPERTY AT 101 NORTH CENTER STREET  
FROM “R” RESIDENTIAL TO “C-1” COMMERCIAL, AFFIRMING THE PLANNING  
COMMISSION’S RECOMMENDATION TO REZONE THIS PROPERTY

ORDINANCE 2025-04 *Sponsors: Councilpersons Benetis, Rufener*  
AN ORDINANCE AUTHORIZING THE INTERIM CITY MANAGER TO ENTER INTO  
AN AGREEMENT TO PURCHASE AND INSTALL A REPLACEMENT INTERMEDIATE  
PUMP FROM HYDROFLO PUMPS AND NATIONAL PUMP & PROCESS INC. FOR THE  
NEWTON FALLS WATER PLANT

ORDINANCE 2025-05 *Sponsors: Councilpersons Axiotis, Stimpert*  
AN ORDINANCE RECOGNIZING JACKSON STREET AREAS 44, 45, AND 46 AS  
PARTS OF AN UNIMPROVED STREET, VACATING AREAS 44, 45, AND 46 OF  
JACKSON STREET, AND TRANSFERRING THE VACATED SECTIONS TO THE  
ADJOINING PROPERTY OWNERS

ORDINANCE 2025-06 *Sponsors: Councilpersons Axiotis, Rufener*  
AN ORDINANCE AUTHORIZING THE INTERIM CITY MANAGER TO ENTER INTO  
AN AGREEMENT TO AMEND THE COMPENSATION PROVISIONS OF THE  
INVESTMENT MANAGEMENT AGREEMENT BETWEEN THE VILLAGE AND  
MEEDER PUBLIC FUNDS, INC.

**XII. Public Comments**

**XIII. Closing Remarks**

- a. Mayor
- b. Council Members
- c. Finance Director
- d. Law Director
- e. City Manager

**XIV. Motion to Recess into Executive Session (If Necessary)**

**MOTION**

A Motion to recess into Executive Session to consider the employment of a public employee or official.

**XV. Adjournment**



NEWTON FALLS CITY COUNCIL  
**REGULAR MEETING MINUTES**  
 Wednesday, February 5, 2025; 6:00 PM  
 COUNCIL CHAMBERS  
 612 WEST BROAD STREET

CITY COUNCIL MEMBERS	
Ward 1	Patricia Benetis
Ward 2	Brian Axiotis
Ward 3	VACANT
Ward 4	Kevin Rufener
At- Large	Julie Stimpert
Mayor	David Hanson

CITY ADMINISTRATION	
Interim City Manager	Mike Novotny
Law Director	Jeff Limbian
Finance Director	Jamie Vernaccini
Clerk of Council	Michael Acomb

**I. Call to Order**

Mayor Hanson called the meeting to order at 6:02 pm.

**II. Pledge of Allegiance / Silent Prayer**

**III. Roll Call**

Mayor Hanson asked Mr. Acomb to call the roll.

Council Present: Councilperson Axiotis, Councilperson Benetis, Councilperson Rufener, Mayor Hanson.

Council Absent: Councilperson Stimpert.

Staff Present: Interim City Manager Novotny, Clerk Acomb, Law Director Limbian.

Staff Absent: Finance Director Vernaccini.

Mr. Axiotis made a Motion to Excuse Ms. Stimpert for a family medical emergency. Seconded by Ms. Benetis.

No discussion.

Roll Call Vote: Mr. Axiotis-yes; Ms. Benetis-yes; Mr. Rufener-yes. The motion passed 3-0. Ms. Stimpert was excused.

**IV. Changes To Tonight's Agenda**

None.

**V. Special Presentations by Staff Members or Invited Consultants**

Presentation of Annual Reports

- Planning and Zoning Commission
  - Adam Zimmerman presented the annual report to Council, including meeting minutes for 8 meetings spending \$0. (Enclosed).
  - The council had no questions.
- Parks and Recreation Board
  - Not Present. No report presented. Report submitted and enclosed.

**VI. Public Comments (Agenda Items Only)**

None.

**VII. Reports**

- a. Mayor – No report.
- b. Council Members
  - i. Ward 1 – No report.

- ii. Ward 2 – He attended the Planning and Zoning Commission meeting which was adjourned to unexpected issues with the agenda items. It was rescheduled for February 11 at 6:00 pm.
- iii. Ward 4 – No report.
- c. Law Director – No report.
- d. Finance Director – She read from a prepared report (Enclosed).
- e. City Manager – He mentioned that pump issues at the water pump continues. He also received engineering information about the Church Street Substation. Information will be forthcoming.

**VIII. Approval of Previous Minutes**

Mayor Hanson called for a motion to approve the Regular Meeting Minutes January 22, 2025. Moved by Ms. Benetis. Seconded by Mr. Rufener.

No discussion.

Roll Call Vote: Mr. Axiotis-yes; Ms. Benetis-yes; Mr. Rufener-yes. The motion passed 3-0. The minutes were approved.

**IX. Public Hearings**

ORDINANCE 2025-01

*Sponsors: Councilpersons Axiotis, Rufener*

AN ORDINANCE AUTHORIZING THE INTERIM CITY MANAGER TO ENTER INTO AN AGREEMENT TO PURCHASE AND INSTALL A REPLACEMENT RAW WATER PUMP FOR THE WATER PLANT

None.

**X. Unfinished Business**

ORDINANCE 2025-01

*Sponsors: Councilpersons Axiotis, Rufener*

AN ORDINANCE AUTHORIZING THE INTERIM CITY MANAGER TO ENTER INTO AN AGREEMENT TO PURCHASE AND INSTALL A REPLACEMENT RAW WATER PUMP FOR THE WATER PLANT

Mayor Hanson read the ordinance by title only and asked for a motion to adopt the ordinance. Moved by Mr. Rufener. Second by Mr. Axiotis.

Mr. Rufener stated that this is the pump that Mr. Zeleny requested and has been included in the budget.

Roll Call Vote: Mr. Axiotis-yes; Ms. Benetis-yes; Mr. Rufener-yes. The motion passed 3-0. Final Reading.

**XI. New Business**

None.

**XII. Public Comments**

Nicholas Marchese. Concrete Couture.

His company performed work during the month of November. They are independent subcontractor working on concrete ramps as part of a Village asphalt project. They were not paid in full in 2024 for the project which was funded with grant money. He requested that Council hold the general contractor accountable so that his company can receive payment. He cannot afford to go to court as a small business. We wants to ensure that the wages of his workers are paid by the general contractor to his business. He clarified that his company was a sub-contractor of a sub-contractor. The general contractor claims that NF never paid them for rejection of the work by the Village. The outstanding balance is about \$7000. He stated that wage reports may have been falsified by someone. Mr. Limbian offered to lead an investigation.

John Noblock – Holland Paving. He is the sub-contractor that was not paid approximately \$90,000 by the general contractor. He contracted Concrete Couture as his sub-contractor. Some minor repairs were needed at the end of the project. The paving

was deemed unacceptable by the general contractor, but Holland never received a notice of unacceptability. He requested that Council investigate and intervene on their behalf. He admitted that he had a short timeline to submit a bid and likely did not do his due diligence with the general contractor prior to signing with them. But, requested help nonetheless because they performed the work satisfactorily and were never paid.

**XIII. Closing Remarks**

- a. Mayor – None.
- b. Council Members
  - i. Ward 1 – Thanks to Chief Fixler for his annual report. She made statements in support of the police department and the need to have one in Newton Falls. There was woman in need on the sidewalk and no emergency forces were called or responded. The Finance Director stated that Chief Fixler is a full-time employee and keeps normal daytime hours. She stated further that she has no information regarding citations and no revenue
  - ii. Ward 2 – The TIB meeting is on Thursday. The Planning and Zoning Commission will meet on January 11. There are vacancies on both and also for the Ward 3 seat on Council. He suggested that Mr. Marchese come to the meeting tonight. He stated belief that the Village paid their bills based on the financial records and advocated the Village no longer use the general contractor if the claims are true.
  - iii. Ward 4 – He thanked the visitors for the public comments and encouraged them to speak with the law director. The summer season is starting and Late Night in the Falls is beginning very soon. He encouraged the public to approach members of Council and to visit the businesses.
- c. Finance Director – She stated that the Village paid all invoices that were received from OHM to the primary contractor. There seem to be remaining unpaid funds; but invoices have not been received for those unpaid funds. She agreed that contractors who don't pay their subcontractors should not be permitted to do business with the Village.
- d. Law Director – None.
- e. City Manager – He received an email today; but did not know about the issue with the contractors until tonight. The Village has paid all invoices received. The bid process was done properly. He will assist with the investigation and expressed surprise that they were not paid; but the City has done their business properly, including the handling of OPWC grant money.

**XIV. Motion to Recess into Executive Session (If Necessary)**

Mayor Hanson called for a Motion to recess into Executive Session to consider the employment of a public employee or official.

the meeting. Moved by Mr. Axiotis. Second by Ms. Benetis.

No discussion.

Roll Call Vote: Mr. Axiotis-yes; Ms. Benetis-yes; Mr. Rufener-yes. The motion passed 3-0. Council entered executive session at 6:33 pm.

Mayor Hanson called for a Motion to exit Executive Session and to resume the regular meeting. Moved by Mr. Rufener. Second by Mr. Axiotis.

No discussion.

Roll Call Vote: Mr. Axiotis-yes; Ms. Benetis-yes; Mr. Rufener-yes. The motion passed 3-0. Council resumed regular session at 7:19 pm.

Chief Fixler was permitted to address Council. He reminded that in cases of true emergency, citizens should use 9-11 or 330-872-5757\*1 to reach the County Dispatcher or 330-675-2730 to reach the Sheriff's Office. The Sheriff handles the calls for the Village and emergencies always receive a response. The Village is not currently contracted or equipped to respond to emergencies.

**XV. Adjournment**

Mayor Hanson called for a motion to adjourn the meeting. Moved by Mr. Rufener. Second by Ms. Benetis.

No discussion.

Roll Call Vote: Mr. Axiotis-yes; Ms. Benetis-yes; Mr. Rufener-yes. The motion passed 3-0. The meeting was adjourned at 7:21 pm.

APPROVED:

\_\_\_\_\_  
David Hanson, Mayor

ATTEST:

\_\_\_\_\_  
Michael Acomb, Clerk of Council

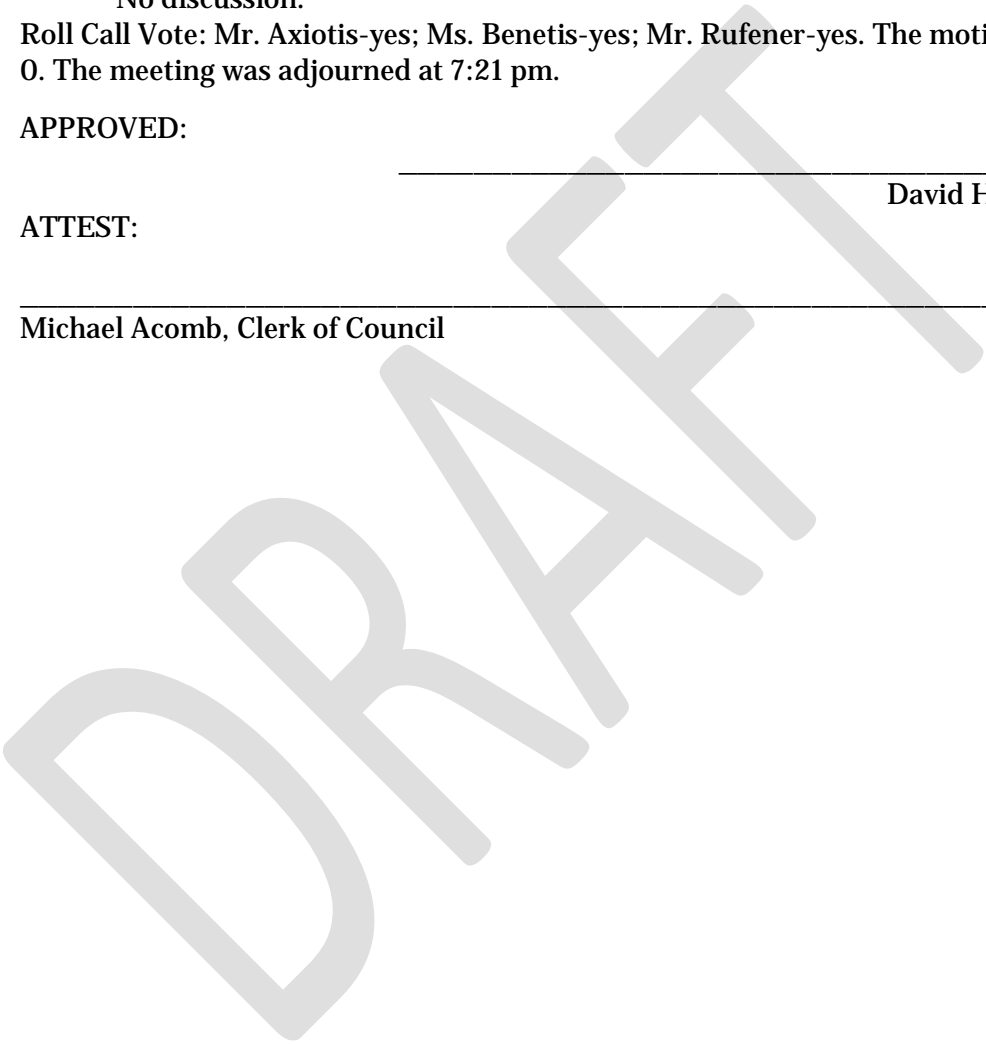

# Newton Falls Planning and Zoning Commission

## Year-end Report

### 2024

#### Commission Members:

- Brian Kropp – Chairman
  - Jeff Derry – Vice Chairman
  - Adam Zimmermann – Secretary
  - Condie Bright
  - Vacant Seat
- 
- John Spelich – Zoning Administrator
  - Brian Axiotis – Council Representative

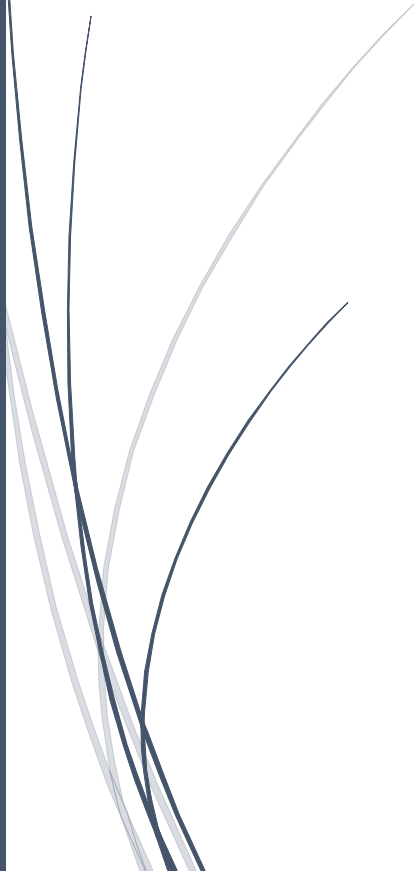

Newton Falls Planning and Zoning Commission

Year-end Report 2024

In this report you will find a summary of each of the meetings held by the Planning and Zoning Commission in 2024. The summary includes the attendance by each Commission member, any Motion that was voted on by the Commission, and any discussions held. If there are any questions on anything in this report, please contact me for clarification.

Meetings: 8

Money spent by Commission: \$0.00

Adam Zimmermann  
Newton Falls Planning and Zoning Commission  
Secretary  
[azimmermann197@gmail.com](mailto:azimmermann197@gmail.com)  
(330) 307-6790



Newton Falls Planning and Zoning Commission

Year-end Report 2024

**January 9<sup>th</sup>, 2024**

1. Roll Call
  - a. Commission Members
    - i. Paul King Present
    - ii. Adam Zimmermann Present
    - iii. Jeff Derry Present
    - iv. Condie Bright Present
    - v. Denny Cottrill Present
  - b. Planning and Zoning Administrator
    - i. John Spelich Present
  - c. Council Representative
    - i. Brian Axiotis Present
2. Election of Officers
  - a. Motion to keep Paul King as Chairman and Adam Zimmermann as Secretary
    - i. Made by Jeff Derry
    - ii. Second by Condie Bright
  - b. Roll Call
    - i. Paul King Yes
    - ii. Adam Zimmermann Yes
    - iii. Jeff Derry Yes
    - iv. Condie Bright Yes
    - v. Jeff Derry Yes
  - c. Motion passed 5-0
3. Approved Motion to consolidate lots owned by Deborah Meyers (Windham and Jay Streets) to allow for the proper frontage necessary to build on the lots.
  - a. Motion made by Paul King
  - b. Seconded by Adam Zimmermann
    - i. Roll Call
      1. Paul King Yes
      2. Adam Zimmermann Yes
      3. Jeff Derry Yes
      4. Condie Bright Yes
      5. Denny Cottrill Yes
    - ii. Motion passes 5-0
4. Discussions
  - a. How can the city have cars and boats removed from public property if they are abandoned.
  - b. What can we do about bed taxes on rehab houses.
  - c. Has the fire department inspected the rehab houses?
  - d. Marijuana and Smoke Shop regulations

Newton Falls Planning and Zoning Commission

Year-end Report 2024

**February 6<sup>th</sup>, 2024**

Meeting called to order at 6:00 pm

Roll Call:

- Commission Members
  - Paul King Absent
  - Adam Zimmermann Present
  - Jeff Derry Present
  - Condie Bright Present
  - Denny Cottrill Present
- Zoning Administrator
  - John Spelich Present
- Council Representative
  - Brian Axiotis Present

Motion to excuse Paul King

- Motion made by Adam Zimmermann
- Second by Condie Bright
  - Roll Call
    - Adam Zimmermann Yes
    - Jeff Derry Yes
    - Condie Bright Yes
    - Denny Cottrill Yes
- Motion Passes 4-0

Discussions

- Rehab Houses
  - Will address questions with the Law Director at a later date.
- Smoke Shops
  - Will address questions with the Law Director at a later date.

Newton Falls Planning and Zoning Commission

Year-end Report 2024

**March 5<sup>th</sup>, 2024**

Roll Call:

- Commission Members
  - Paul King Present
  - Adam Zimmermann Present
  - Jeff Derry Present
  - Condie Bright Absent
  - Denny Cottrill Present
- Zoning Administrator
  - John Spelich Present
- Council Representative
  - Brian Axiotis Present

Discussions

- Rehab Houses
  - Open discussion with Law Director Jeff Limbian regarding what possibly could be done to limit rehab houses, restrict their locations, and the legalities involved in such actions.
- Smoke Shops
  - Open discussion with Law Director Jeff Limbian regarding what possibly could be done to limit smoke shops, restrict their locations, and the legalities involved in such actions. Discussion also included what other communities have done and what could be done in the future as far as possibly proposing legislation to Council.

Newton Falls Planning and Zoning Commission

Year-end Report 2024

April 2<sup>nd</sup>, 2024

Roll Call:

- Commission Members
  - Paul King Present
  - Adam Zimmermann Present
  - Jeff Derry Present
  - Condie Bright Absent
  - Denny Cottrill Absent
- Zoning Administrator
  - John Spelich Present
- Council Representative
  - Brian Axiotis Absent
  
- Motion for a variance for 5 4's Distillery to allow overnight RV camping on their commercial property for a one-time event.
  - Motion made by Adam Zimmermann
  - Second by Jeff Derry
    - Roll Call:
      - Paul King No
      - Adam Zimmermann No
      - Jeff Derry No
  - Motion failed 3-0

Public Comments/Presentation

- David McKinstry of the Newton Falls Area Commerce Association (NFACA) presented a plan to update the sign in "Kiwanis Corner" of 4 Corners Park with a Community Bulletin Board that would be installed and maintained by the NFACA. The plan was approved by the Kiwanis Club of Newton Falls. Dave McKinstry was going to pursue with John Spelich whether a zoning variance was necessary or not. If a variance was necessary, he was going to bring it back to the board for approval.

Newton Falls Planning and Zoning Commission

Year-end Report 2024

**May 7<sup>th</sup>, 2024**

Roll Call:

- Commission Members
  - Paul King Present
  - Adam Zimmermann Present
  - Jeff Derry Present
  - Condie Bright Absent
  - Denny Cottrill Absent
- Zoning Administrator
  - John Spelich Present
- Council Representative
  - Brian Axiotis Present

Discussions:

- Newton Falls Area Commerce Association (NFACA) sign in “Kiwanis Corner” of Four Corners Park. How is the area of sign calculated? The NFACA is being asked to apply for a variance due to the size of the total sign and sign being located within the “sight triangle” of the roads.
- Discussion on Ordinance 2024-07.
  - Passed first reading by City Council
  - Language is similar to legislation passed by Lordstown.
- Donnie Reid 5 4’s Distillery
  - Wants information on the old Baryak property and what he can do with it.
  - Plans on joining Harvest Hosts which would provide free overnight RV camping on his property.
  - Also planning car shows and bike shows.
  - Also looking to add an outdoor seating area that can accommodate outdoor concerts.
  - Discussion on Commercial vs. Industrial zoning
  - Discussion on alcohol on old Baryak property
- David Carpenter – L&V Properties
  - Presented to the Commission that he wanted to subdivide 7 lots on Milton Blvd.
  - These lots would use city utilities.
  - Approval from the Commission was first step necessary before going to county to officially have the lot re-platted.
  - After discussion, a motion was made to approve the re-platting of the properties.
- Motion to approve the re-platting of the properties on Milton Blvd.
  - Motion made by Adam Zimmermann
  - Second by Paul King
  - Roll Call

Newton Falls Planning and Zoning Commission

Year-end Report 2024

- Paul King Yes
- Adam Zimmermann Yes
- Jeff Derry Yes
- Denny Cottrill Yes
- Motion Passed 4-0

Newton Falls Planning and Zoning Commission

Year-end Report 2024

**July 2<sup>nd</sup>, 2024**

Roll Call:

- Commission Members
  - Paul King Present
  - Adam Zimmermann Present
  - Jeff Derry Present
  - Condie Bright Present (Arrived at 6:04 pm)
  - Denny Cottrill Absent
- Zoning Administrator
  - John Spelich Present
- Council Representative
  - Brian Axiotis Present

**\*\*\*Condie Bright arrived and participated in the rest of the meeting.\*\*\***

Old Business:

- NFACA/Kiwanis sign in 4 Corners Park
  - The City Manager was not sure that a variance was needed to progress with the sign installation. The old (current) sign is not located in the sight triangle of the corner. Another question arose if one variance or 3 variances might be necessary if new sign is significantly moved due to being 3 panels and not just one pane. The sign is ordered and scheduled to be delivered July 18 – 27.

New Business:

- A discussion regarding reverting Clonch properties from Residential back to Commercial that were changed to commercial on the last Zoning Map.
  - The discussion started by noting that the Comprehensive Plan was put together to evaluate plans for the future. Discussion on how the plan came into effect and what was done in the past. Roy Clonch was advised to make a variance request for every property that he would like reverted to Commercial. He was advised to go through the Zoning Inspector with his variance requests and then they would be presented to the Planning and Zoning Commission for review. The properties discussed were: 35 Vine St., 55 East Jay St., 49 Jay St., and 43 Jay St.

Discussions:

- Township Resident and Business Owner Tom Colosimo brought up DORA (Designated Outdoor Refreshment Area) and how it would benefit the downtown businesses. He would like to see this presented back to council. Discussion on how this would benefit the businesses in our downtown shopping district. It was mentioned that we had 4 businesses downtown that sell alcohol and could benefit from this. Discussion on how the City of Warren is currently limiting their DORA to special weekends with a police presence.

Newton Falls Planning and Zoning Commission

Year-end Report 2024

- Discussion on the price of food truck registration. The pricing of the registration was discussed with how this is limiting the amount of food trucks that come into our town. Also discussed how this might be affecting the businesses that are bringing in the food trucks that are paying for their registration for the food trucks. Discussion to continue at the next meeting.



Newton Falls Planning and Zoning Commission

Year-end Report 2024

**September 3<sup>rd</sup>, 2024**

Roll Call:

- Commission Members
  - Paul King Present
  - Adam Zimmermann Present
  - Jeff Derry Absent (At time of roll call; arrived 6:07 pm)
  - Condie Bright Present
- Zoning Administrator
  - John Spelich Present
- Council Representative
  - Brian Axiotis Present

**\*\*\*Jeff Derry arrived and participated in the rest of the meeting.\*\*\***

Old Business:

- Food Truck Pricing
  - Discussion ensued on the current pricing of food truck permits and whether a motion should be made to have City Council make a motion to adjust the price of the permits.
    - Pros and cons of adjusting the permit price
    - Would a seasonal pass (summer months) be appropriate?
    - Would adjusting the price of the permit hurt or help businesses?
    - Would adjusting the price of the permit be beneficial to the city?
  - No action was taken at this time

Newton Falls Planning and Zoning Commission

Year-end Report 2024

October 1<sup>st</sup>, 2024

Roll Call:

- Commission Members
  - Paul King Present
  - Adam Zimmermann Present
  - Jeff Derry Present
  - Condie Bright Absent
- Zoning Administrator
  - John Spelich Present
- Council Representative
  - Brian Axiotis Present

New Business:

- Request to revert Jerry Daniel property (101 N. Center St.) from Residential to Commercial.
  - Jerry Daniel: 712 Beaver St., Girard, OH addressed the Commission.
  - Discussion was had on Jerry Daniel not knowing when property was changed from Commercial to Residential zoning. No one had the answer to that at the time of Commission meeting.
  - Jerry has the deed to the property, but it doesn't list how it was zoned.
  - Discussion ensued on what could be done that night to have the property rezoned. It was stated that the Commission did not have the authorization to rezone property on its own and that belonged with City Council.
  - It was recommended that Jerry Daniel put in a formal request in writing to the Zoning Administrator to start moving forward on this issue
  - Roy Clonch also addressed the commission at this time on what it would take to have his properties rezoned from Residential back to Commercial.
  - He stated that there was no notification given at the time of the rezoning on the status change to his property.
  - It was also stated to him that the Commission did not have the authority to rezone property and that belonged with City Council.
  - It was also recommended that he put a formal request in writing to the Zoning Administrator to start moving forward on this issue.
  - No formal action was taken by the Commission at this time.
  
- David McKinstry (NFACA) to present Maintenance Agreement between Newton Falls Area Commerce Association (NFACA) and the Kiwanis Club of Newton Falls for sign in Four Corners Park.
  - David McKinstry was not present to present the Maintenance Agreement to the Commission.

Newton Falls Planning and Zoning Commission

Year-end Report 2024

- An email from the Law Director was presented to the Commission stating that he had no issues with the agreement.
- The Maintenance Agreement was determined not to be a zoning issue that needed to be addressed by the Commission.
- No action was taken on the Maintenance Agreement.
  
- Motion to accept the combining of lots 255, 256, & 257 in Rose Park Allotment into one parcel.
  - Discussion was had on what happened once the Commission approved the motion. It was explained that it then went to the county for final approval.
  - Paul King stated that he had no issues with combining the lots.
  - Adam Zimmermann also stated that he saw no issues with this.
    - Motion made by Paul King
    - Second by Jeff Derry
      - Roll Call
        - Paul King Yes
        - Adam Zimmermann Yes
        - Jeff Derry Yes
    - Motion Passes 3-0

## Parks and Recreation Committee Annual Report 2024

Committee members: Laura Neiheisel, chair; Heidi Zimmermann, secretary; John Donato  
Council Representative: Brenda Persino

The focus of the committee in 2024 was on upkeep of the city's playgrounds.

Accomplishments in this area included

1. Installation of one ADA swing at the pavilion play area.
2. New mulch at every city playground.
3. Fresh paint and artwork at the skate park.

All P&R projects continue to be funded out of the city's budget allocation with the approval of council and/or the city manager. All financial information can be found on the city website.

This committee believes that the ongoing needs of the playgrounds and parks far surpass the budget provided, and we suggest that council and CM consider consulting with a grant writer who has the ability and knowledge to pursue and procure any matching funds available.

P&R would like to thank the school administration, students, and citizen volunteers for all their hard work on removing the graffiti and updating the skate park.

We also wish to thank the CM and Council for their cooperation and especially Council Rep Brenda Persino for her dedication, enthusiasm and many hours of behind the scenes work for the committee.



## Finance Directors Report

To: Members of Council  
David Hanson, Mayor  
Mike Novotny, City Manager  
Jeff Limbian, Law Director

From: Jamie Vernaccini, Director of Finance

Date: February 5, 2025

Subject: Finance Department

---

I would like to personally thank the Electric and the Water Departments. These departments pushed through extra work installing the remaining new utility meters on a tight schedule. The Finance Department can now begin the conversion of the accounting software from EGOV to VIP as these meters are now communicating with the EGOV system.

### January Month End:

The Finance Office successfully closed out the month of January without any significant reconciling issues. The EGOV system now reflects the appropriations adopted by Council in the Fall

### TIB:

The TIB Quarterly meeting is next week. The TIB is still missing one community member if anyone is interested in filling this position please contact the Finance Director or Brian Axiotis for more information.

VILLAGE OF NEWTON FALLS, OHIO  
RESOLUTION NO.: 01-2025  
SPONSOR: Councilpersons Benetis, Rufener

**A RESOLUTION REVISING THE METHODOLOGY USED TO DETERMINE ADMINISTRATIVE OVERHEAD COST ALLOCATIONS IN ORDER TO ASSIGN THE SHARED COST OF AN ITEM OR SERVICE TO THE GENERAL FUND, THE WATER REVENUE FUND, THE SEWER REVENUE FUND AND THE ELECTRIC REVENUE FUND OF VILLAGE OF NEWTON FALLS TO ENSURE THAT COSTS ARE SHARED EQUITABLY ACROSS THESE FUNDING SOURCES.**

WHEREAS, Council wishes to revise Resolution 22-2015, which established a method for determining administrative overhead cost allocations for the General Fund, Water Revenue Fund, the Sewer Revenue Fund, and the Electric Revenue Fund; and

WHEREAS, after careful review and consideration, and as recommended by the Finance Director, Council has determined that the revised method designated in "Exhibit A" is a more appropriate methodology for the Village of Newton Falls.

NOW, THEREFORE, BE IT ORDAINED, by the Council of the Village of Newton Falls, Ohio:

SECTION 1: That Council hereby revises the methodology used to determine administrative overhead cost allocations to the procedure designated in "Exhibit A", attached hereto as if fully written herein, and designates that this revised methodology shall be used to determine the administrative cost overhead allocations until otherwise revised.

SECTION 2. That all formal actions of this Council concerning and relating to the adoption of this Resolution were taken in an open meeting of this Council, and all deliberations of this Council or any of its committees that resulted in such formal action were taken in meetings open to the public and/or in compliance with all legal requirements, including Section 121.22 of the Ohio Revised Code.

SECTION 3. That this Resolution shall take effect immediately upon adoption in accordance with Article III, Section 22 of the Charter of Newton Falls.

PASSED IN COUNCIL THIS \_\_\_\_\_ DAY OF \_\_\_\_\_, 2025.

\_\_\_\_\_  
David Hanson, Mayor

Attest:

\_\_\_\_\_  
Michael Acomb, Clerk of Council

Approved as to Legal Form.

\_\_\_\_\_  
Jeff Limbian, Law Director

VILLAGE OF NEWTON FALLS, OHIO  
ORDINANCE NO.: 2025-02  
SPONSORS: Councilpersons Rufener, Stimpert

**AN EMERGENCY ORDINANCE APPROVING THE RECODIFICATION, EDITING,  
AND INCLUSION OF CERTAIN ORDINANCES AS PARTS OF THE VARIOUS CODES  
OF THE CODIFIED ORDINANCES OF NEWTON FALLS, OHIO**

WHEREAS, various ordinances of a general and permanent nature have been passed which should be included in the Codified Ordinances of Newton Falls, Ohio; and

WHEREAS, Council desires to amend the Village Codified Ordinances accordingly.

NOW, THEREFORE, the Council of the Village of Newton Falls, State of Ohio, hereby ordains:

SECTION 1: That the editing, arrangement and numbering of those ordinances and resolutions enacted by Council from December 1, 2023 to December 1, 2024, are hereby approved and adopted as printed in the 2024 Replacement Pages to the Codified Ordinances so as to achieve uniformity of style and classification. A copy of such replacement pages are attached to this ordinance and incorporated as a part hereof.

SECTION 2: That the following sections of the Traffic, General Offenses, and Building Codes, as amended, are hereby approved and adopted as amended or enacted so as to conform to enactments of the Ohio General Assembly:

Traffic Code

- 301.35 School Bus. (Amended)
- 303.01 Compliance with Lawful Order of Police Officer; Fleeing. (Amended)
- 303.083 Impounding Vehicles on Public Property. (Amended)
- 303.10 Leaving Junk Vehicles on Private Property with Permission of Owner. (Amended)
- 303.991 Committing an Offense While Distracted Penalty. (Amended)
- 331.38 Stopping for School Bus; Discharging Children. (Amended)
- 331.46 Restrictions on the Operation of School Buses. (Added)
- 333.03 Maximum Speed Limits; Assured Clear Distance Ahead. (Amended)
- 333.07 Street Racing, Stunt Driving and Street Takeovers Prohibited. (Amended)
- 333.11 Electronic Wireless Communication Device Use Prohibited While Driving. (Amended)
- 337.16 Number of Lights; Limitations on Flashing, Oscillating or Rotating Lights. (Amended)
- 337.26 Child Restraint System Usage. (Amended)
- 337.32 Lights and Sign on Transportation for Preschool Children. (Added)
- 341.04 Commercial Drivers Prohibitions. (Amended)
- 341.05 Criminal Offenses. (Amended)
- 351.04 Parking Near Curb; Handicapped Locations on Public and Private Lots and Garages. (Amended)

ORDINANCE NO.: 2025-02

General Offenses Code

- 501.01 General Provisions and Penalty Definitions. (Amended)
- 505.19 Rights of Blind, Deaf or Hearing Impaired, or Mobility Impaired Person, or Trainer with Assistance Dog. (Added)
- 509.06 Inducing Panic. (Amended)
- 509.10 Impeding Public Passage of an Emergency Service Responder. (Added)
- 513.01 Drug Abuse Control Definitions. (Amended)
- 513.02 Gift of Marihuana. (Amended)
- 513.16 Adult Use Cannabis Control; Limitations on Conduct by Individuals. (Added)
- 529.07 Open Container Prohibited. (Amended)
- 533.03 Unlawful Sexual Conduct with a Minor. (Amended)
- 533.04 Sexual Imposition. (Amended)
- 533.08 Procuring; Engagement in Sexual Activity for Hire. (Amended)
- 537.02 Vehicular Homicide and Manslaughter. (Amended)
- 537.021 Vehicular Assault in a Construction Zone. (Amended)
- 537.03 Assault. (Amended)
- 537.12 Misuse of 9-1-1 System. (Amended)
- 537.16 Illegal Distribution of Cigarettes, Other Tobacco Products, or Alternative Nicotine Products; Transaction Scans. (Amended)
- 549.10 Possessing Replica Firearm in School. (Amended)
- 549.12 Concealed Handgun Licenses; Possession of Revoked or Suspended License; Additional Restrictions; Posting Signs Prohibiting Possession.

SECTION 3: That all formal action of this Council concerning and relating to the adoption of this Ordinance was taken in an open meeting of this Council, and all deliberations of this Council or any of its committees that resulted in such formal action were taken in meetings open to the public and/or in compliance with all legal requirements, including Section 121.22 of the Ohio Revised Code.

SECTION 4: That this Ordinance is hereby declared to be an emergency measure necessary for the immediate preservation of the public peace, health, safety and welfare of the residents of the City, the reason for the necessity being that there exists an imperative need for the earliest publication and distribution of the 2024 Replacement Pages to the Codified Ordinances to the officials and residents of the City, so as to facilitate administration, daily operation and avoid practical and legal entanglements.

PASSED IN COUNCIL THIS \_\_\_\_\_ DAY OF FEBRUARY, 2025.

\_\_\_\_\_  
David Hanson, Mayor

Attest:

\_\_\_\_\_  
Michael Acomb, Clerk of Council

Approved as to Legal Form.

\_\_\_\_\_  
Jeff Limbian, Law Director



VILLAGE OF NEWTON FALLS, OHIO  
ORDINANCE NO.: 2025-02  
SPONSORS: Councilpersons Benetis, Stimpert

**AN EMERGENCY ORDINANCE APPROVING THE RECODIFICATION,  
EDITING, AND INCLUSION OF CERTAIN ORDINANCES AS PARTS OF THE  
VARIOUS CODES OF THE CODIFIED ORDINANCES OF NEWTON FALLS, OHIO**

Link to the Exhibit for Ordinance 2025-02 – [Click here to download](#)

VILLAGE OF NEWTON FALLS, OHIO  
ORDINANCE NO.: 2025-03  
SPONSOR: Councilpersons Axiotis, Rufener

**AN ORDINANCE REZONING THE PROPERTY AT 101 NORTH CENTER STREET FROM “R” RESIDENTIAL TO “C-1” COMMERCIAL, AFFIRMING THE PLANNING COMMISSION’S RECOMMENDATION TO REZONE THIS PROPERTY**

WHEREAS, on January 7, 2025, the Village Planning Commission voted to recommend the rezoning of the property at 101 North Center Street based on the owner’s application to rezone the property from “R” Residential to “C” Commercial.

NOW, THEREFORE, the Council of the Village of Newton Falls, State of Ohio, hereby ordains:

SECTION 1. That Council hereby rezones the property at 101 North Center Street from “R” to “C-1” based on the Planning Commission’s recommendation to grant the change based on the application to rezone the property, finding that the amendment is warranted due to changes of an economic, physical, or social nature within the area involved which were not anticipated by the comprehensive plan and which have substantially altered the basic characteristics of the area.

SECTION 2. That Council hereby and herein approves the recommendation of the Planning and Zoning Commission to waive the rezoning fee of \$200 typically payable by the property owner.

SECTION 3. That all formal actions of this Council concerning and relating to the adoption of this Ordinance were taken in an open meeting of this Council, and all deliberations of this Council or any of its committees that resulted in such formal action were taken in meetings open to the public and/or in compliance with all legal requirements, including Section 121.22 of the Ohio Revised Code.

SECTION 4. That this Ordinance shall be effective as of the earliest date permitted by law.

PASSED IN COUNCIL THIS \_\_\_\_\_ DAY OF \_\_\_\_\_, 2025

\_\_\_\_\_  
David Hanson, Mayor

Attest:

\_\_\_\_\_  
Michael Acomb, Clerk of Council

Approved as to Legal Form.

\_\_\_\_\_  
Jeff Limbian, Law Director

VILLAGE OF NEWTON FALLS, OHIO  
ORDINANCE NO.: 2025-04  
SPONSOR: Councilpersons Axiotis, Rufener

**AN ORDINANCE AUTHORIZING THE INTERIM CITY MANAGER TO ENTER INTO AN AGREEMENT TO PURCHASE AND INSTALL A REPLACEMENT INTERMEDIATE PUMP FROM HYDROFLO PUMPS AND NATIONAL PUMP & PROCESS INC. FOR THE NEWTON FALLS WATER PLANT**

WHEREAS, the existing intermediate pump at the Water Plant has failed and no longer operates properly; and

WHEREAS, the Water Department Superintendent and Interim City Manager investigated and received options for the purchase and installation services of a replacement pump, as well as the removal and disposal services for the existing pump; and

WHEREAS, pursuant to Ohio Revised Code Section 9.17, formal advertisement and bidding are not required as the purchase is less than \$75,000; and

WHEREAS, Village Council desires to accept the quotation (Exhibit A) from Hydroflo Pumps and National Pump & Process Inc. located at 180 Treat Road, Aurora, OH 44202., for the purchase and installation services of a replacement pump, as well as the removal and disposal services for the existing pump, as it was determined by the Interim City Manager to be the most cost-effective corrective measure and the lowest and best price for the project; and

WHEREAS, adequate funds for such a request are available for use in 2025.

NOW, THEREFORE, the Council of the Village of Newton Falls, State of Ohio, hereby ordains:

SECTION 1. That Council hereby and herein authorizes the Interim City Manager to enter into an agreement with Hydroflo Pumps and National Pump & Process Inc. located at 180 Treat Road, Aurora, OH 44202, to purchase a replacement intermediate pump and to contract with said company for installation services and removal/disposal services of the existing pump for \$24,662.00 as set forth in the attached quotation (Exhibit A).

SECTION 2. That all formal action of this Council concerning and relating to the adoption of this Ordinance was taken in an open meeting of this Council, and all deliberations of this Council or any of its committees that resulted in such formal action were taken in meetings open to the public and/or in compliance with all legal requirements, including Section 121.22 of the Ohio Revised Code.

SECTION 3. That this Ordinance shall be effective as of the earliest date permitted by law.

ORDINANCE NO.: 2025-04  
PAGE 2

PASSED IN COUNCIL THIS \_\_\_\_\_ DAY OF \_\_\_\_\_, 2025.

\_\_\_\_\_  
David Hanson, Mayor

Attest:

\_\_\_\_\_  
Michael Acomb, Clerk of Council

Approved as to Legal Form.

\_\_\_\_\_  
Jeff Limbian, Law Director



**QUOTATION**

Date: February 10, 2025

**ZERO LEAD PUMPS®**

Quote #: 2502006

Project: Newton Falls WTP

Job #: Intermediate Pump

Page #: 1 of 10

**Attention:** *CODY ZELENY*  
**E-Mail:** *Waterplant@ci.newtonfalls.oh.us*  
**Phone:** *330-719-2175*  
**Fax:** *330-719-2175*  
**Company:** *Newton Falls WTP*  
**Address:** *175 W. River Rd*  
**City, State:** *Newton Falls OH*

**From:** *MATT GLOVA*  
**E-Mail:** *National Pump & Process*  
**Phone:** *matt@nationalpump.com*  
**Fax:** *216-316-3097*  
**Address:** *180 Treat Rd*  
**City, State:** *Aurora, OH 44202*

Qty	Part #	Description	Unit Price	Total
		* <b>DESIGN: 1102 USGPM @ 40.1' TDH, 1770 RPM, * 75% Efficient, 14.9 BHP, 172.27 Inch TPL (+/- 1.5")</b>		
1	9ZC2C-58401-w_B0	<b>9ZC - 2 Stage W/L VERTICAL TURBINE PUMP ASSEMBLY</b> *** Fully Assembled Vertical Turbine *** <b>DRIVER ASSEMBLY SECTION</b> <ul style="list-style-type: none"> <li>• US 20HP, 1800RPM, 3PH/60Hz/230-460V, Premium Efficient, 256TPH Frame VHS-WP1 w/ NRR and 1.1875" Drive Coupling</li> <li>– Motor Type: AUS</li> <li>– <b>Motor CD = 23.38"</b></li> </ul> <b>DISCHARGE HEAD ASSEMBLY SECTION</b> <ul style="list-style-type: none"> <li>• 1.1875" x 29.38" x 416SS Head Shaft Assembly w/ 12TPI-LH Bronze Adjusting Nut and Key</li> <li>• F-Style Fabricated Steel Head with 8" 150# RF Discharge Flange for 12" BD with 19" W x 19" L x 1.25" Thick Integral Base</li> <li>– Shaft Guard: Special Fabrication</li> <li>– 1.1875" Cast Iron Packing Box Assembly w/ B10 C932 Bronze Bearing, John Crane #1345 Packing, Bronze Lantern Ring and SS Packing Gland</li> <li>• Base Plate: Standard Steel HF8 24.0" W x 24.0" L x 1.0" Thick</li> </ul> <b>COLUMN ASSEMBLY SECTION</b> <ul style="list-style-type: none"> <li>• 3 Piece Column Assembly: ~ 140.75" of 8" x .322" Wall x 4' 11-1/4" Steel Water Lubricated Column with Threaded Couplings</li> <li>• 2 Pc(s): 8" x 2" x .75" Spiders w/ Rubber Inserts</li> <li>• 3 Piece Lineshaft Assembly: 1.1875" -WL 12 TPI x 60" x 416SS w/ 416SS Couplings</li> <li>– Top Shaft: 1.1875" -WL 12 TPI x 416SS w/ 416SS Coupling</li> <li>– Lineshaft: 1.1875" -WL 12 TPI x 416SS w/ 416SS Couplings</li> </ul> <b>BOWL ASSEMBLY SECTION</b> <ul style="list-style-type: none"> <li>• 9ZC - 2 Stage Product Lubricated Bowl Assembly w/ 18-8 SS Fasteners including:               <ul style="list-style-type: none"> <li>– 8" Butt Thread, Ductile Iron Discharge Case with B10 C932 Bronze Bearing</li> <li>– Ductile Iron Bowls</li> <li>– B10 C932 Bronze Bowl Bearings</li> <li>– 201SS Impellers with 316SS Collets</li> <li>– 416SS Bowl Shaft: 8.00" Water Lube Projection x 1.1875" DIA - WL 12 TPI</li> <li>– 8" NPT, Ductile Iron Suction Case with B10 C932 Bronze Bearing</li> </ul> </li> <li>• <b>* Special Bowl Notes:</b> <ul style="list-style-type: none"> <li>– <b>NO STRAINER PER CUSTOMER REQUEST.</b></li> </ul> </li> <li>• Crating and Painting</li> <li>• <b>Min. Submergence from Bottom of Suction for Vortex Suppression = 33" (In.).</b>                **This does not include NPSHr requirements. NPSHr at Duty Point = 13.6' (Ft.)</li> <li>• <b>.Estimated Total Assembly Weight As Above: 2323 Lbs.</b></li> <li>• <b>Standard time to have ready to ship is ~ 12 to 14 weeks A.R.O. based on current inventory and factory loads.</b></li> </ul>	\$ 24,662.00	\$ 24,662.00

Shipment time is an approximation based on current inventory and factory production schedules. Quotation is valid for 30 days from Quote date.

Company: Newton Falls WTP  
 Date: 2/10/2025



**Pump:**

Size: 9ZC (2 stage)  
 Type: Vertical  
 Synch Speed: 1800 rpm  
 Curve: 010311  
 Specific Speeds:  
 Dimensions:  
 Vertical Turbine:

Speed: 1770 rpm  
 Dia: 7.46 in  
 Impeller: 9ZC SS ENCL.  
 Ns: ---  
 Nss: ---  
 Suction: 8 in  
 Discharge: 8 in  
 Bowl Size: 9.5 in  
 Max Lateral: 0.5 in  
 Thrust K Factor: 13.6 lbf/ft

**Search Criteria:**

Flow: 1100 US gpm Head: 40 ft

**Fluid:**

Water  
 Density: 62.32 lb/ft<sup>3</sup>  
 Viscosity: 0.9946 cP  
 NPSHa: ---

Temperature: 68 °F  
 Vapor Pressure: 0.3391 psi a  
 Atm Pressure: 14.7 psi a

**Motor:**

Standard: NEMA  
 Enclosure: WP1  
 Sizing Criteria: Max Power on Design Curve

Size: 20 hp  
 Speed: 1800 rpm  
 Frame: 256T

**Pump Limits:**

Temperature: 140 °F  
 Pressure: 300 psi g  
 Sphere Size: 1.44 in

Power: 270 hp  
 Eye Area: 26.7 in<sup>2</sup>

---- Duty Point ----	
Flow:	1102 US gpm
Head:	40.1 ft
Eff:	75%
Power:	14.9 hp
NPSHr:	13.6 ft
---- Design Curve ----	
Shutoff Head:	79.1 ft
Shutoff dP:	34.2 psi
Min Flow:	231 US gpm
BEP:	75.3% @ 1155 US gpm
NOL Power:	19.6 hp @ 400 US gpm
-- Max Curve --	
Max Power:	33.5 hp @ 400 US gpm

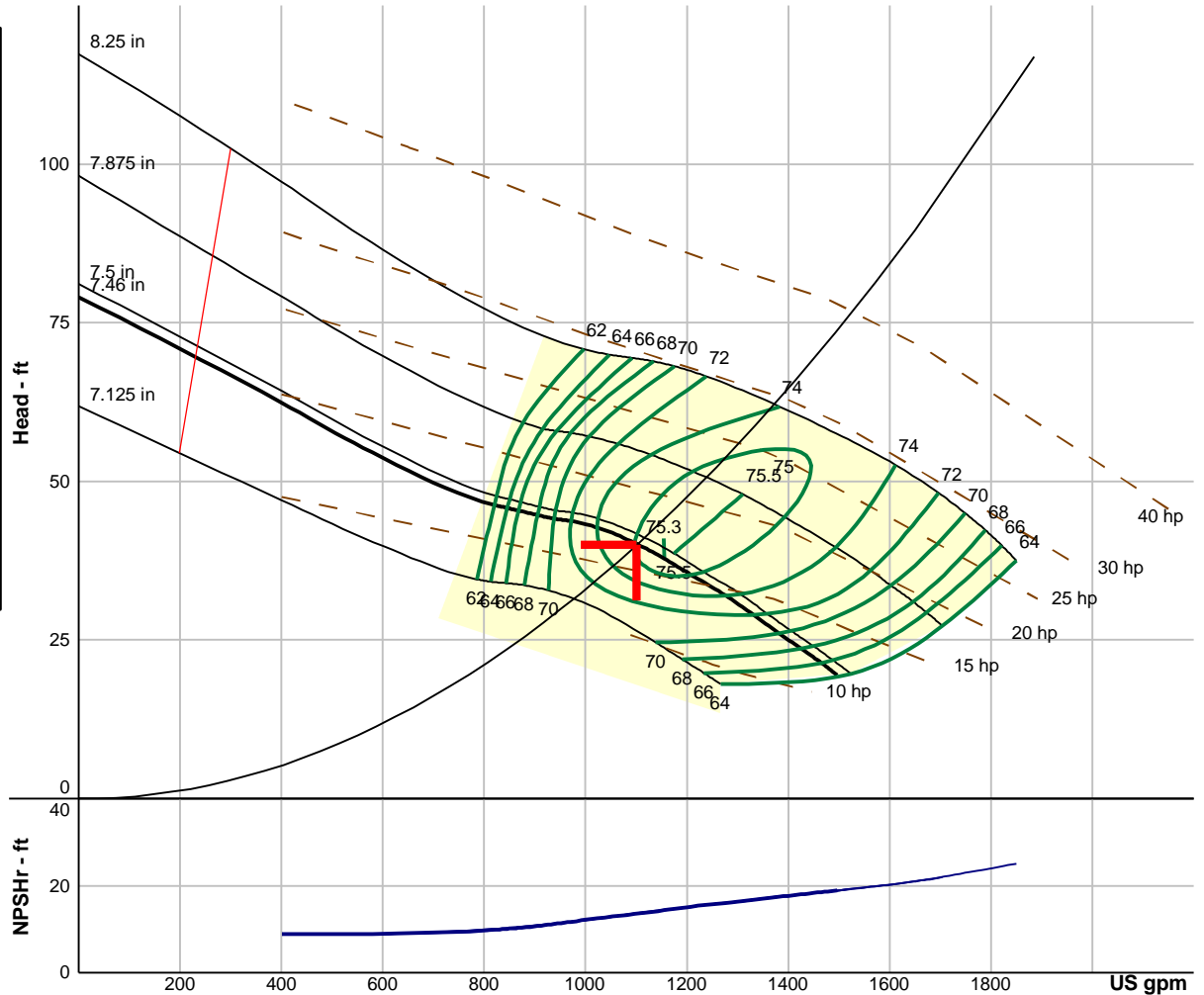

**Performance Evaluation:**

Flow US gpm	Speed rpm	Head ft	Efficiency %	Power hp	NPSHr ft
1320	1770	29.6	72.4	13.6	16.7
1100	1770	40.2	75	14.9	13.6
880	1770	45.2	66.7	15	10.5
660	1770	51.8	50.4	17.1	9.31
440	1770	60.7	34.9	19.2	9

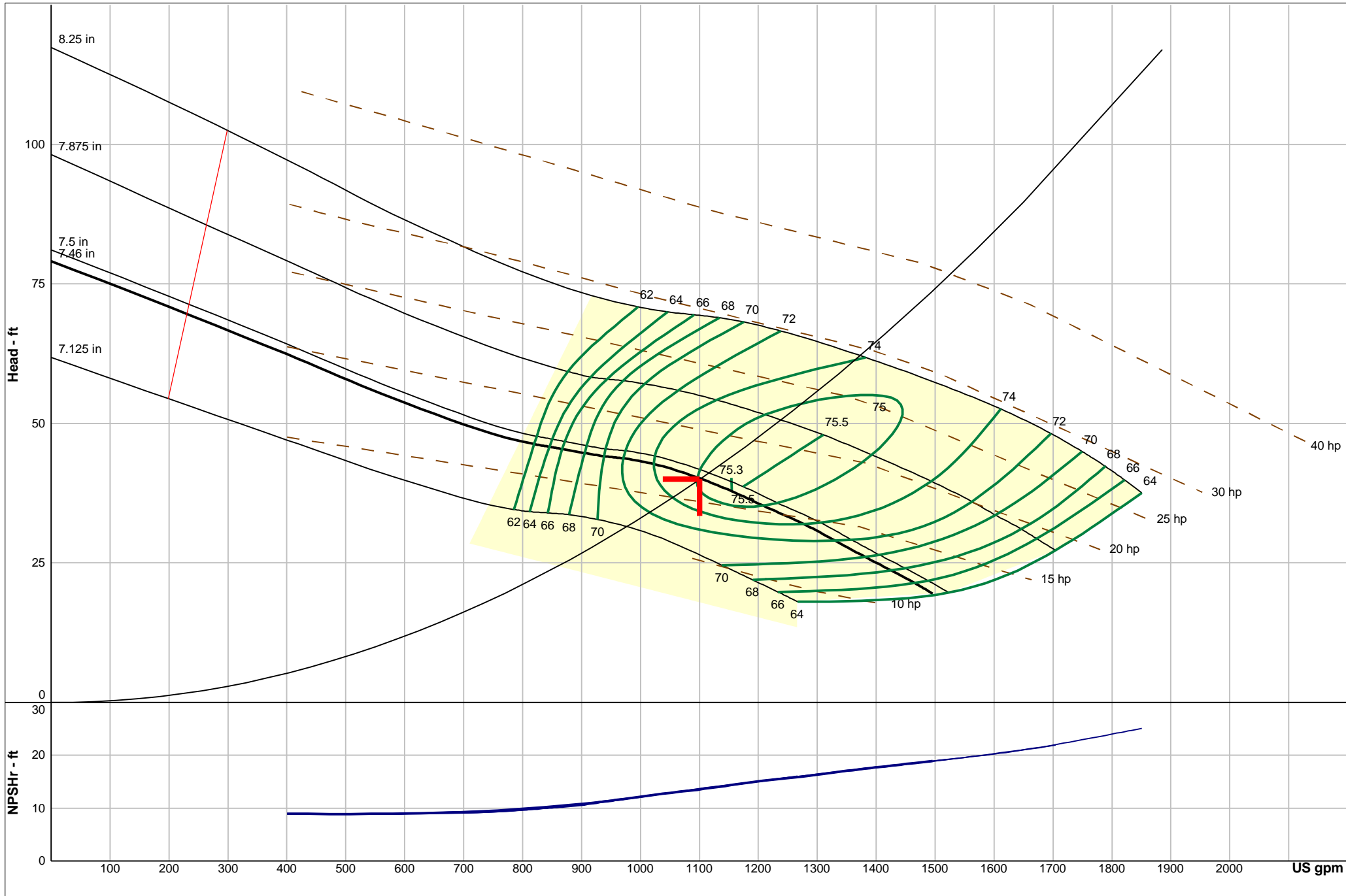

Company: National Pump & Process, Inc.  
 Name:  
 2/10/2025

Hydroflo Pumps USA, Inc.  
 Catalog: Hydroflo VS Pumps.60, Vers 18.3  
 Vertical - 1800 rpm  
 Design Point: 1100 US gpm, 40 ft

Size: 9ZC (2 stage)  
 Speed: 1770 rpm  
 Dia: 7.46 in  
 Curve: 010311  
 Impeller: 9ZC SS ENCL.











ItemNo.	Qty.	Description	Material Grade
1	1	Bowl Shaft	416 Stainless Steel
5	1	Bearing - Oil Tube Adapter (Half Bearing)	BRZ C932
9	2	Pipe Plug - Discharge	A-197 Black Iron
10	1	Bearing - Discharge Case	C93200 Bronze
12	1	Discharge Case	A-536 GR. 65-45-12
14	12	Bolt - Discharge Case	18-8 Stainless Steel
16	2	Bowl	A-536 GR. 65-45-12
18	2	Bearing - Bowl	C93200 Bronze
19	2	Impeller Collet	316 Stainless Steel
20	2	Impeller	201 Stainless Steel
23	12	Bolt - Bowl	18-8 Stainless Steel
24	12	Bolt - Suction	18-8 Stainless Steel
25	1	Suction - Threaded	A-536 GR. 65-45-12
27	1	Sand Collar	201 Stainless Steel
28	1	Bearing - Suction	C93200 Bronze
29	1	Pipe Plug - Suction	A-197 Black Iron

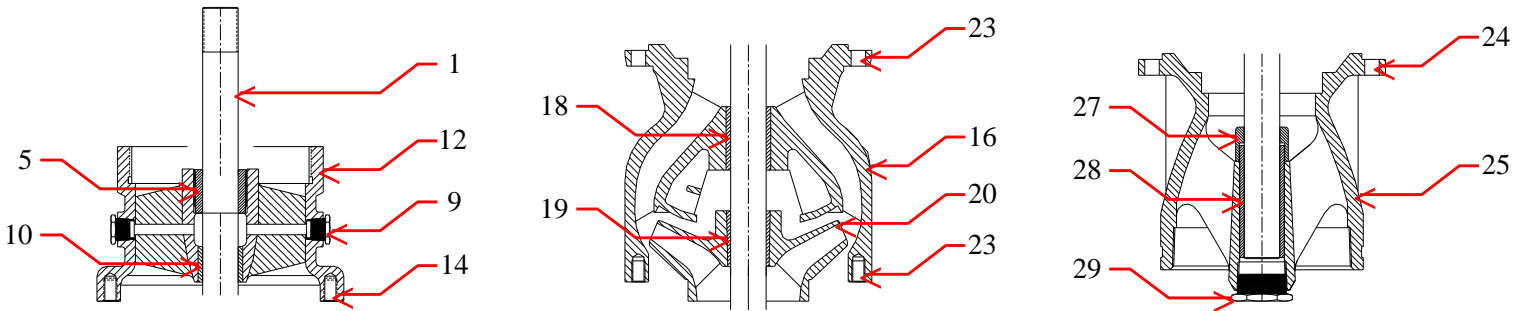

Pump Model: 9ZC - 2 Stage

NOT FOR CONSTRUCTION

Config #: C-58401-w

**NOTICE**

This drawing is the confidential property of Hydroflo Pumps USA, Inc., a Taco Group Company and is furnished for your information only and must not be made public or copied and must be returned on demand. Manufacture of parts per this drawing is expressly forbidden except by written authorization from Hydroflo Pumps USA, Inc., a Taco Group Company. All rights of design and invention are reserved and patents pending.



HYDROFLO PUMPS USA, INC.  
 7118 LOBLOLLY PINE BLVD.  
 FAIRVIEW, TN 37062  
 PHONE: 615.799.9662  
 FAX: 615.799.5654

**National Pump & Process, Inc.**  
**9ZC - 2 Stage Water Lube**  
**Vertical Turbine Pump System**

REV	DATE	REVISION	CH

REFERENCE	HYDROFLO PUMPS INC. WORK ORDER NO.	CUSTOMER P.O. NO.	General Arrangement Design Specifications		
PUMP S.N.	NO. REQD: Qty	DR BY: Config DATE: 2/10/2025	DWG. NO.	SHT.	REV.
MATERIAL: NOTED		CK BY: DATE:			

# NIDEC MOTOR CORPORATION

8050 WEST FLORISSANT AVE.  
ST. LOUIS, MO 63136



**DATE:** 2/10/2025

**P.O. NO.:** FZ74  
**Order/Line NO.:** 25886 MN 100

**TO:**

**Model Number:** FZ74  
**Catalog Number:** HO20P2BLF  
VHS Weather Protected  
CONF,MOTOR,VHS WPI

**REVISIONS:**  
(NONE)

**ALL DOCUMENTS HEREIN ARE CONSIDERED CERTIFIED BY NIDEC MOTOR CORPORATION.  
THANK YOU FOR YOUR ORDER AND THE OPPORTUNITY TO SERVE YOU.**

**Features:**

Horsepower ..... 00020.00~00000.00 ~ KW: 14.92  
Enclosure ..... WPI  
Poles ..... 04~00 ~ RPM: 1800~0  
Frame Size ..... 256~TPH  
Phase/Frequency/Voltage.. 3~060~230/460  
Winding Type ..... Random Wound  
Service Factor ..... 1.15  
Insulation Class ..... Class "F" ~ Insulife 1000  
Altitude In Feet (Max) .. 3300 Ft.(1000 M) ~ +40 C  
Efficiency Class ..... Premium Efficiency  
Application ..... Vertical Centrifugal Pump  
Customer Part Number ....  
12" Base ~ Coupling Size: 1" Bore, 1/4" Key  
Non-Reverse Ratchet ~ Steady Bushing Not Requested  
Pricebook Thrust Value (lbs).. 3300  
Customer Down Thrust (lbs) ... 3200  
Customer Shutoff Thrust (lbs).  
Up Thrust (lbs): ~  
Temperature Rise (Sine Wave): "B" Rise @ 1.0 SF (Resist)  
Starting Method ..... PWS (Dual Volt-Low Volt Only)  
Duty Cycle ..... Continuous Duty  
Efficiency Value ..... 93.0 % ~ Typical  
Load Inertia: NEMA ~ Standard Inertia: 99.00 LB-FT2  
Number Of Starts Per Hour: NEMA  
Motor Type Code ..... AUS  
Rotor Inertia (LB-FT<sup>2</sup>) ..... 2.27 LB-FT<sup>2</sup>  
Qty. of Bearings PE (Shaft) ..... 1  
Qty. of Bearings SE (OPP) ..... 1  
Bearing Number PE (Shaft) ..... 7310 BEP  
Bearing Number SE (OPP) ..... 6210-2Z-J/C3

Nidec trademarks followed by the ® symbol are registered with the U.S. Patent and Trademark Office.

# NIDEC MOTOR CORPORATION

8050 WEST FLORISSANT AVE.  
ST. LOUIS, MO 63136



**DATE:** 2/10/2025

**P.O. NO.:** FZ74  
**Order/Line NO.:** 25886 MN 100

**TO:**

**Model Number:** FZ74  
**Catalog Number:** HO20P2BLF  
VHS Weather Protected  
CONF,MOTOR,VHS WPI

**REVISIONS:**  
(NONE)

**ALL DOCUMENTS HEREIN ARE CONSIDERED CERTIFIED BY NIDEC MOTOR CORPORATION.  
THANK YOU FOR YOUR ORDER AND THE OPPORTUNITY TO SERVE YOU.**

**Accessories:**

Counter CW Rotation FODE  
115 Volt Space Heaters  
Special Balance  
Stamp Following On Main N/P:  
100% HT  
Standard Leadtime: NA  
F.O.B.:

**USE THE DATA PROVIDED BELOW TO SELECT THE APPROPRIATE DIMENSION PRINT**

<b>Horsepower</b>	20
<b>Pole(s)</b>	04
<b>Voltage(s)</b>	460-230
<b>Frame Size</b>	256TPH
<b>Outlet Box AF</b>	2.59
<b>Outlet Box AA</b>	1.50

Nidec trademarks followed by the ® symbol are registered with the U.S. Patent and Trademark Office.

EFFECTIVE:  
**27-AUG-24**

SUPERSEDES:  
**07-JUL-16**

# DIMENSION PRINT

## OVERSIZED OUTLET BOX

FRAME: 250TP, TPA, TPH  
BASIC TYPE: AU

PRINT:  
**09-2289-03**

SHEET:  
**1 OF 1**

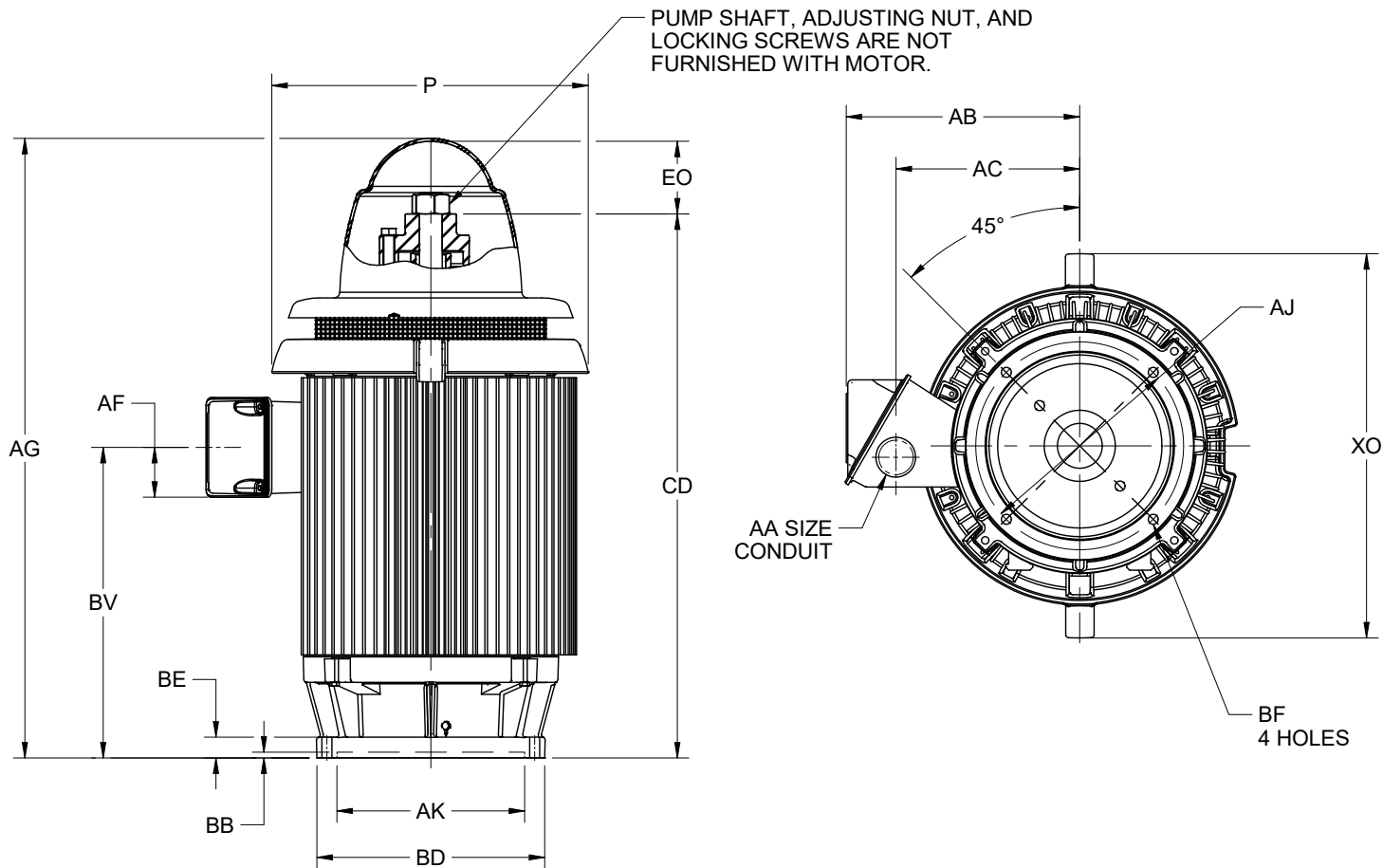

ALL DIMENSIONS ARE IN INCHES AND MILLIMETERS

UNITS	P <sup>2</sup>	AA	AB	AC	AF	AG <sup>5</sup>	BB MIN	BE	BV <sup>5</sup>	CD <sup>5</sup>	EO	XO
IN	14.00	1.50	11.00	8.31	2.59	26.75	.25	.94	13.50	23.38	3.25	16.88
MM	356		279	211	66	679	6	24	343	594	83	429

FRAME	UNITS	AJ	AK	BD MAX	BF
254,256TP	IN	9.125	8.250	10.00	.44
	MM	231.78	209.55	254	11
254,256TPA	IN	14.750	13.500	16.50	.69
	MM	374.65	342.90	419	18
254,256TPH	IN	9.125	8.250	12.00	.44
	MM	231.78	209.55	305	11

TOLERANCES	8.250 AK	13.500 AK
FACE RUNOUT	.004 T.I.R.	.007 T.I.R.
PERMISSIBLE ECCENTRICITY OF MOUNTING RABBET	.004 T.I.R.	.007 T.I.R.
TOLERANCE ON AK-DIMENSION	+.003	+.005

- ALL ROUGH DIMENSIONS MAY VARY BY .25" IN DUE TO CASTING AND/OR FABRICATION VARIATIONS.
- LARGEST MOTOR WIDTH.
- TOLERANCES SHOWN ARE IN INCHES ONLY.

- CONDUIT OPENINGS MAY BE LOCATED IN STEPS OF 180 DEGREE REGARDLESS OF LOCATION. STANDARD AS SHOWN WITH CONDUIT OPENING DOWN.
- DIMENSIONS SHOWN ARE FOR ALL RATINGS EXCEPT 20 HP, 4 POLE, TYPE AUE AND AUJ. FOR THIS RATING THE DIMENSIONS ARE: AG=28.13 (715 MM)  
CD=24.75 (629 MM)  
BV=15.38 (391 MM)

09-2289/E

**Nidec Motor Corporation**  
St. Louis, Missouri

INFORMATION DISCLOSED ON THIS DOCUMENT IS CONSIDERED PROPRIETARY AND SHALL NOT BE REPRODUCED OR DISCLOSED WITHOUT WRITTEN CONSENT OF NIDEC MOTOR CORPORATION



ISSUED BY  
**G. MARTINEZ**  
APPROVED BY  
**L. ARROYO**

IHP\_DP\_NMCA (MAR-2011) SOLIDEDGE



**ADDITIONAL NAMEPLATE DATA:**

Decal / Plate	WD=159833,CP=132839	Customer PN	
Notes		Non Rev Ratchet	NRR
Max Temp Rise	80C RISE/RES@1.00SF	OPP/Upper Oil Cap	GREASE
Thermal (WDG)		SHAFT/Lower Oil Cap	GREASE
Altitude		Usable At	
Regulatory Notes		Regulatory Compliance	
COS		Marine Duty	
Balance	0.08 IN/SEC	Arctic Duty	
3/4 Load Eff.	93.8	Inrush Limit	
Motor Weight (LBS)	300	Direction of Rotation	
Sound Level		Special Note 1	
Vertical Thrust (LBS)	3300	Special Note 2	
Thrust Percentage		Special Note 3	
Bearing Life		Special Note 4	
Starting Method		Special Note 5	
Number of Starts		Special Note 6	100% HT
200/208V 60Hz Max Amps		SH Max. Temp.	
190V 50 hz Max Amps		SH Voltage	SH VOLTS=115V
380V 50 Hz Max Amps		SH Watts	SH WATTS= 48W
NEMA Inertia		Load Inertia	
Sumpheater Voltage		Sumpheater Wattage	
Special Accessory Note 1		Special Accessory Note 16	
Special Accessory Note 2		Special Accessory Note 17	
Special Accessory Note 3		Special Accessory Note 18	
Special Accessory Note 4		Special Accessory Note 19	
Special Accessory Note 5		Special Accessory Note 20	
Special Accessory Note 6		Special Accessory Note 21	
Special Accessory Note 7		Special Accessory Note 22	
Special Accessory Note 8		Special Accessory Note 23	
Special Accessory Note 9		Special Accessory Note 24	
Special Accessory Note 10		Special Accessory Note 25	
Special Accessory Note 11		Special Accessory Note 26	
Special Accessory Note 12		Special Accessory Note 27	
Special Accessory Note 13		Special Accessory Note 28	
Special Accessory Note 14		Special Accessory Note 29	
Special Accessory Note 15		Special Accessory Note 30	
Heater in C/B Voltage		Heater in C/B Watts	
Zone 2 Group		Division 2 Service Factor	
Note 1		Note 2	
Note 3		Note 4	
Note 5		Note 6	
Note 7		Note 8	
Note 9		Note 10	
Note 11		Note 12	
Note 13		Note 14	
Note 15		Note 16	
Note 17		Note 18	
Note 19		Note 20	
Note 21		Note 22	

**NIDEC MOTOR CORPORATION  
ST. LOUIS, MO**

TYPICAL NAMEPLATE DATA  
ACTUAL MOTOR NAMEPLATE LAYOUT MAY VARY  
SOME FIELDS MAY BE OMITTED



Nidec trademarks followed by the ® symbol are registered with the U.S. Patent and Trademark Office.



## MOTOR PERFORMANCE

MODEL NO.	CATALOG NO.	PHASE	TYPE	FRAME
FZ74	HO20P2BLF	3	AUS	256TPH
ORDER NO.		25886	LINE NO.	
MPI:			249236	337543
HP:			20	20
POLES:			4	4
VOLTS:			460	230
HZ:			60	60
SERVICE FACTOR:			1.15	1.15
EFFICIENCY (%):				
S.F.			92.7	92.7
FULL			93	93
3/4			93.8	93.8
1/2			93.3	93.3
1/4			90.1	90.1
POWER FACTOR (%):				
S.F.			84.5	84.5
FULL			83.8	83.8
3/4			80.6	80.6
1/2			72.3	72.3
1/4			51.4	51.4
NO LOAD			5.1	5.1
LOCKED ROTOR			47.4	47.4
AMPS:				
S.F.			27.5	55
FULL			24	48
3/4			18.6	37
1/2			13.9	27.7
1/4			10.1	20.2
NO LOAD			8.6	17.2
LOCKED ROTOR			151	308
NEMA CODE LETTER			G	G
NEMA DESIGN LETTER			B	B
FULL LOAD RPM			1775	1775
NEMA NOMINAL / EFFICIENCY (%)			93	93
GUARANTEED EFFICIENCY (%)			91.7	91.7
MAX KVAR			5.8	5.8
AMBIENT (°C)			40	40
ALTITUDE (FASL)			3300	3300
SAFE STALL TIME-HOT (SEC)			25	25
SOUND PRESSURE (DBA @ 1M)			0	0
TORQUES:				
BREAKDOWN{% F.L.}			253	253
LOCKED ROTOR{% F.L.}			246	271
FULL LOAD{LB-FT}			59.2	59.2

NEMA Nominal and Guaranteed Efficiencies are up to 3,300 feet above sea level and 25 ° C ambient.

The Above Data Is Typical, Sinewave Power Unless Noted Otherwise

**NIDEC MOTOR CORPORATION**  
ST. LOUIS, MO





159833

**Motor Wiring Diagram**

9 Lead, Dual Voltage, Delta Connection  
Part Winding Start (PWS) on Low Voltage

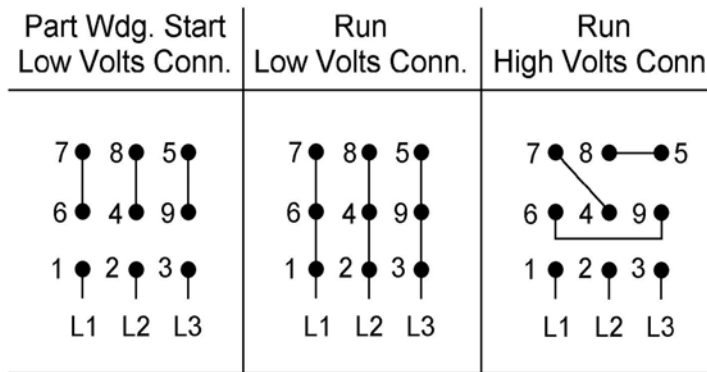

Motor good for across the line starting

Per NEMA MG1 1998-1.75, "A Part-winding Start motor is one which certain specially designed circuits of each phase of the primary winding are initially connected to the supply line. The remaining circuit or circuits of each phase are connected to the supply in parallel with initially connected circuits, at a predetermined point in the starting operation." This is intended to limit the inrush current required to start the motor. NEMA MG1 1998-14.38 states that the motor may not accelerate to full speed in part-winding and may be noisier than when on full winding.

Motors designed by US Motors for Part-winding Start also be used for across the line starting using only the full winding connection. Damage will occur if the motor is operated with load for more than 2 seconds on Part-winding without transition to full winding.

To reverse direction of rotation, interchange leads L1 & L2.

Each lead may have one or more cables comprising that lead. In such case, each cable will be marked with the appropriate lead number.



**159833**

## **SPECIAL INFORMATION REGARDING PART WINDING STARTING**

This motor is not designed to fully accelerate when started with the part winding start connection shown on the motor connection diagram. In order to avoid damaging the motor when it is started with the part winding start connection, set timers so that the motor starter switches the motor connection from start to run within two seconds from the time that the motor is initially energized. The motor is not expected to fully accelerate before the motor connection is switched to run, but the momentary operation on the start connection should allow time for automatic voltage regulators on the power system to compensate for voltage dip resulting from the high current draw of the motor during acceleration. Thus, voltage dip in the power system will be minimized through proper use of the part winding start connection. Once the motor has been switched over to the run connection, it will finish accelerating up to full speed.

During the time that the motor is operated on the part winding start connection, it is expected that the motor may be noisier than when operated on the run connection and it is also expected that the line amp unbalance between phases may be approximately 100% to 150%. This is due to the adverse effect of harmonics that result from the unbalanced magnetic circuit on the part winding start connection.

For further information regarding characteristics of polyphase induction motors when operated on a part winding start connection, refer to NEMA Publication MG 1-1998 Part 14.38.



970798

# SPACE HEATER CONNECTION DIAGRAM

SPACE HEATER LEADS MAY BE LOCATED IN EITHER THE MAIN OUTLET BOX  
OR IF SO EQUIPPED, AN AUXILIARY BOX

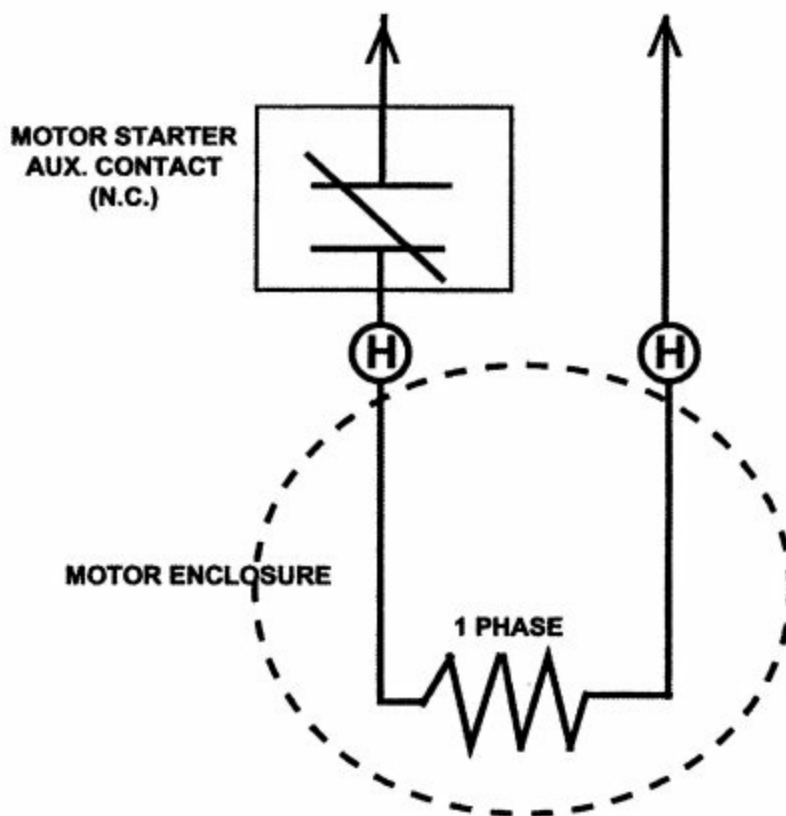

THIS EQUIPMENT IS SUPPLIED WITH ANTI-CONDENSATION HEATERS. HEATERS SHOULD BE ENERGIZED WHEN EQUIPMENT IS NOT OPERATING TO PROTECT UNIT BY PREVENTING INTERNAL CONDENSATION. CONNECT THE "H" OR HEATER LEADS TO

<b>115V</b> VOLTS	<b>48W</b> WATTS RATING
-------------------	-------------------------

**SPACE HEATER NAMEPLATE (ON MOTOR)**

Revision: 7/30/2008  
Mike Cullen

# Vertical HOLLOSHAFT Coupling Dimensions

## Standard Coupling Dimensions

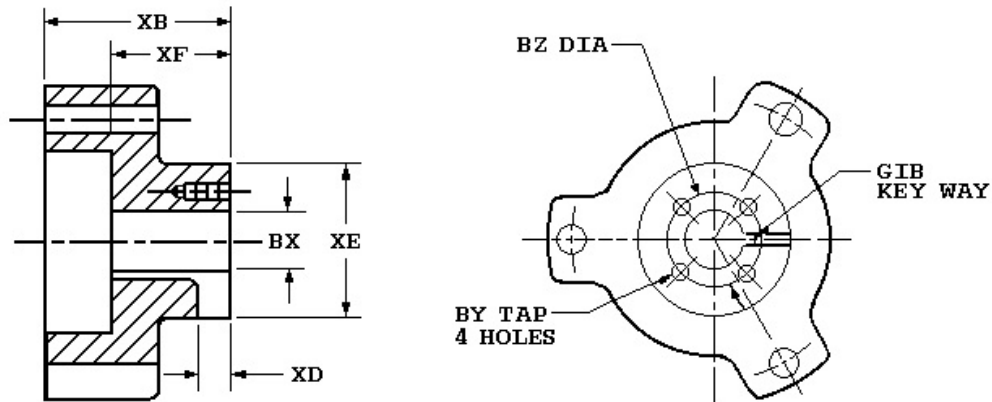

Coupling Part Number	102999
BX Nominal	1
Actual Bore	1.001
BY	10-32
BZ	1 3/8
XB	2 9/16
XD	13/32
XE	2 1/4
XF	1 5/8
SQ. KEY	1/4

### Notes:

1. All Rough casting dimensions may vary by 0.25" due to casting variations.
2. All tapped holes are Unified National Course, Right Hand thread.
3. Coupling bore dimension "BX" is machined with a tolerance of  $-.000$ ",  $+.001$ " up to 1.50" bore inclusive. Larger bores:  $-.000$ ",  $+.002$ ".



## TYPICAL REED CRITICAL FREQUENCY DATA

Note: Motor RCF Test Data can be provided at time of motor shipment through special test.  
Please contact your Nidec Motor Corporation representative for more information.

MODEL NO: FZ74  
CATALOG NO: HO20P2BLF

Frame: 256TPH Type: AUS

REED CRITICAL FREQUENCY:	78	HZ
CENTER OF GRAVITY:	11	IN
DEFLECTION @ CENTER OF GRAVITY:	0.0016	IN
UNIT WEIGHT:	300	LBS
BASE DIAMETER:	ALL	IN
TOLERANCE ON RCF VALUE:	10%	
DATE:	2/10/2025	



Copyright © 2010 Nidec Motor Corporation. All rights reserved.



# DIRECTION OF ROTATION

This motor is unidirectional and can only be operated in one direction to ensure proper cooling.

The motor will be supplied with the industry standard CCW (counter clockwise) rotation as shown below. CW rotation is available upon request.

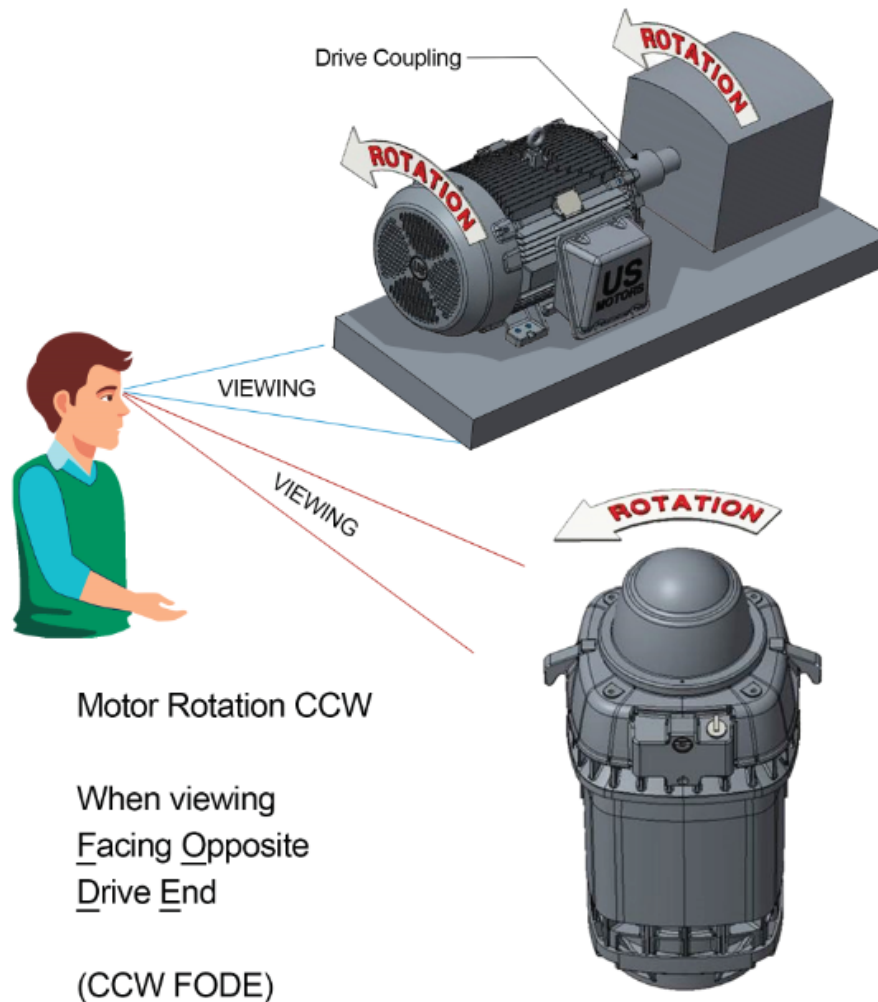

**NIDEC MOTOR CORPORATION**  
ST. LOUIS, MISSOURI

**80-289**

# General Information for Integral Horsepower (IHP) Motors on Variable Frequency Drives (VFDs)

## Variable Frequency Drives (VFD)

A VFD is a type of controller used to vary the speed of an electric motor. The VFD takes a fixed AC voltage and frequency and allows it to be adjusted in order to get different speeds from the motor. Motor speed can be varied by changing the frequency of the input power waveform. The equation below shows how the frequency affects the speed of a three phase induction motor.

$$\text{Speed} = \frac{120 * \text{Fundamental Input Frequency}}{\text{Number of Motor Poles}}$$

## How does a VFD work?

A VFD takes the fixed frequency and voltage sine wave from the power grid or power station and puts it through a few steps in order to allow the VFD user to vary the frequency and in turn control the motor speed. First it rectifies the AC power into DC Power. Because of this step, a term commonly used instead of VFD is inverter. This only describes one step of what the VFD does to the power waveform. Once rectified into a DC voltage the drive sends the power through a set of transistors or switches. These switches can take the DC waveform and by opening and closing at certain speeds and durations can create an output waveform that mimics the sine wave that is required to drive a three phase electric motor. The output wave form is known as a Pulse Width Modulation (PWM) waveform because the waveform is created by multiple pulses of the switches at short intervals.

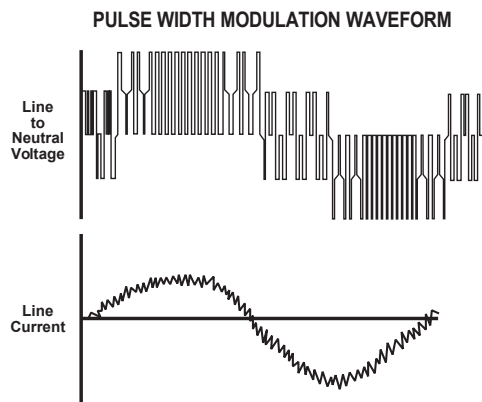

## What variables should be considered when deciding whether to power a motor with a VFD?

VFD compatibility with motors is complex. As a result, many variables must be considered when determining the suitability of a particular motor for use with a VFD. These variables include:

- Torque requirements (Constant or Variable)
- Speed Range
- Line / System Voltage
- Cable length between the VFD and the motor
- Drive switching (carrier) frequency
- Motor construction

- VFD dv/dt - winding end turn differential in voltage versus differential in time
- High temperatures or high humidity
- Grounding system

Wider speed ranges, higher voltages, higher switching frequencies, insufficient grounding and increased cable lengths all add to the severity of the application and, therefore, the potential for premature motor failure.

## How does a VFD affect the motor?

There are many things to consider when a motor is powered using a VFD or PWM power. When a motor is powered by a PWM waveform the motor windings very often see a large differential voltage, either from phase to phase or turn to turn. When the voltage differential becomes large enough it creates a reaction at the molecular level that converts available oxygen into O<sub>3</sub>. This phenomenon is called partial discharge or corona. This reaction creates energy in the form of light and heat. This energy has a corrosive effect on the varnish used to protect the motor windings. PWM waveforms can also magnify shaft voltages which lead to arcing across the bearing and causing premature bearing failure. Corrective action must be taken to mitigate these issues that arise when using an electric motor with a VFD.

## How do I protect the motor?

Nidec Motor Corporation (NMC) has developed specific motor designs to decrease the harmful affects that a VFD can have on a motor. NMC's INVERTER GRADE<sup>®</sup> insulation system is the first line of defense against corona and phase to phase faults that can be common when a motor is powered using a PWM waveform. The INVERTER GRADE<sup>®</sup> insulation system is standard on all of NMC's Inverter Duty products. Along with the INVERTER GRADE<sup>®</sup> insulation, thermostats are installed as a minimum protection against over heating the motor. Special consideration must also be given to bearings in motors powered by VFD's. In order to create a low resistance path to ground for built up shaft voltages a shaft grounding device can be used. On larger horsepower motors an insulated bearing system should be used in conjunction with the shaft grounding device when installed, to force the stray shaft voltages to ground. The bearing failures are more prominent on motors with thrust handling bearings. NMC has created an Inverter Duty vertical motor line that not only uses the INVERTER GRADE<sup>®</sup> insulation system, but that also comes standard with a shaft grounding device. On motors that are 100 HP and greater the thrust bearing is also insulated for additional protection.

## What does "Inverter Duty" mean?

An Inverter Duty motor should describe a motor that helps mitigate potential failure modes of a motor that is powered by a VFD. Inverter duty motor windings should be able to withstand the voltage spikes per NEMA MG1 Part 31.4.4.2 and protect against overheating when the motor is run at slow speeds. On thrust handling bearings it is apparent that the bearings require additional protection. Inverter Duty vertical motors should have a shaft grounding device to protect the motor bearings from fluting due to voltage discharge through the bearing. On larger motors (100HP and larger) the shaft should also be electrically isolated from the frame in order to aid the shaft grounding ring in discharging the shaft voltages to ground.

\*This information applies only to Integral Horsepower (IHP) motors as defined on the Agency Approval page, under UL<sup>®</sup> & CSA<sup>®</sup> listings where indicated.



## Thermal Overloads and Single Phase Motors

Motors with thermal overloads installed may not operate properly on a VFD. The current carrying thermal overload is designed for sine wave power. Operation on a VFD may cause nuisance tripping or potentially not protect the motor as would be expected on line power. Thermostats or thermistors installed in the motor and connected properly to the VFD may provide suitable thermal overload protection when operating on a VFD. (consult codes for installation requirements)

Single phase motors and other fractional horsepower ratings are not designed to be operated on a VFD. Within Nidec Motor Corporation standard products, all motors NEMA<sup>®</sup> 48 frame (5.5" diameter) and smaller are not suitable for VFD applications. Three phase 56 and 143/145 frame applications should be noted on the catalog price page; or if in doubt ask a Nidec Motor Corporation technical representative for recommendations on compatibility with a VFD.

## Slow Speed Motors

Motors with a base design of slower than six poles require special consideration regarding VFD sizing and minimizing harmonic distortion created at the motor terminals due to cable installation characteristics. Additional external PWM waveform filters and shielded motor cables designed for PWM power may be required to provide acceptable motor life. Harmonic distortion on the output waveform should be kept to a minimum level (less than 10%) mismatch impedance.

## 690V Applications

Motors that are rated for 690VAC and that will be powered by 690VAC PWM VFDs require the use of an external filter to limit peak voltage spikes and the use of an INVERTER GRADE<sup>®</sup> motor. Where available, an alternative to using an output filter is to upgrade to a 2300V insulation system.

## Low Voltage TITAN<sup>®</sup> Motors

When using 449 frame and larger motors on PWM type VFDs consider the use of an external filter and shielded motor cables designed for PWM power to minimize harmonic distortion and peak voltages at the motor terminals. Harmonic distortion on the output waveform should be kept to a minimum level (less than 10%).

## Bearing Currents Related to PWM Waveforms

Protection of the motor bearings from shaft currents caused by common mode voltages is becoming a standard feature on Inverter Duty motor products. Some installations may be prone to a voltage discharge condition through the motor bearings called Electrical Discharge Machining (EDM) or fluting. Vertical HOLLOWSHAFT and HOSTILE DUTY World Motor come with grounding devices installed as standard. EDM damage is related to characteristics of the PWM waveform, and the VFD programming, and installations factors.

### Bearing Protection on Inverter Duty Vertical Motors

All U.S. MOTORS<sup>®</sup> brand "Inverter Duty" vertical products have a shaft grounding system that allows damaging shaft currents a low resistance path to ground. **Bearings on vertical motors fed by VFD power without this bearing protection are not covered under any warranty.** All other bearing failure is covered per NMC's standard warranty. An electric motor repair shop approved to service U.S. MOTORS<sup>®</sup> brand motors must verify that the cause of the bearing failure was not due to EDM damage.

## Guideline For Insulated Anti-Friction Bearings

Bearing insulation is required to prevent circulating shaft currents which can damage bearings. Circulating shaft current can be caused by use of improper power and/or ground cables, improper grounding systems and higher switching frequencies. Finding and correcting the external condition(s) is the responsibility of the system designer or specifying engineer. To prevent circulating shaft current in motors with anti-friction bearings, Nidec Motor Corporation's standard practice is to insulate the non-drive end bearing.

Adjustable Speed Drives produce a common mode voltage condition. To interrupt common mode voltage on induction motors of all sizes, NEMA MG1-2018 Part 31 recommends insulating both bearings. In cases where both anti-friction bearings are insulated, the system designer or specifying engineer should determine whether to apply one or more of the following options to prevent or reduce shaft currents: sinewave filters, line reactors or mechanical devices, such as shaft grounding or an insulated half coupling. Motors with shaft grounding devices are not suitable for installation in hazardous locations unless housed in an enclosure suitable for the specified Division (or Zone), Class and Group(s).

## Multiple Motors on a Single VFD

Special considerations are required when multiple motors are powered from a single VFD unit. Most VFD manufacturers can provide guidelines for proper motor thermal considerations and starting/stopping of motors. Cable runs from the VFD and each motor can create conditions that will cause extra stress on the motor winding. Filters may be required at the motor to provide maximum motor life.

## Grounding and Cable Installation Guidelines

Proper output winding and grounding practices can be instrumental in minimizing motor related failures caused by PWM waveform characteristics and installation factors. VFD manufacturers typically provide detailed guidelines on the proper grounding of the motor to the VFD and output cable routing. Cabling manufacturers provide recommended cable types for PWM installations and critical information concerning output wiring impedance and capacitance to ground.

## Integrated Motor and Inverter

By integrating the motor and inverter at NMC's manufacturing facility, many of the motor compatibility problems are minimized or eliminated. During the manufacturing process, the motor is matched to the inverter characteristics which ensures the winding temperature and torque levels meet the design specification. Since the inverter output wiring to the motor is nearly eliminated, bearing currents are rarely experienced. When the unit is properly grounded, reducing the output cable lengths in conjunction with an inverter grade insulation system and low factory setting of the switching frequency of the inverter drive, results in low risk of voltage peaks produced by the PWM waveform.

## Vertical Motors on VFDs

Vertical motors operated on VFD power present unique conditions that may require consideration by the user or installation engineer:

- Locked rotor and drive tripping caused by non-reversing-ratchet operation at low motor speeds. It is not recommended to operate motors at less than 1/4 of synchronous speed. If slow speeds are required contact NMC engineering.
- Unexpected / unacceptable system vibration and or noise levels caused by the torque pulsation characteristics of the PWM waveform, a system critical frequency falling inside the variable speed range of the process or the added harmonic content of the PWM waveform exciting a system component
- Application related problems related to the controlled acceleration/deceleration and torque of the motor on VFD power and the building of system pressure/ load.
- The impact the reduction of pump speed has on the down thrust reflected to the pump motor and any minimum thrust requirements of the motor bearings
- Water hammer during shutdown damaging the non-reversing ratchet

## Humidity and Non-operational Conditions

The possible build-up of condensation inside the motor due to storage in an uncontrolled environment or non-operational periods in an installation, can lead to an increased rate of premature winding or bearing failures when combined with the stresses associated with PWM waveform characteristics. Moisture and condensation in and on the motor winding over time can provide tracking paths to ground, lower the resistance of the motor winding to ground, and lower the Corona Inception Voltage (CIV) level of the winding.

Proper storage and maintenance guidelines are important to minimize the potential of premature failures. Space heaters or trickle voltage heating methods are the common methods for drying out a winding that has low resistance readings. **Damage caused by these factors are not covered by the limited warranty provided for the motor unless appropriate heating methods are properly utilized during non-operational periods and prior to motor start-up.**

NEMA<sup>®</sup> Application Guide for AC Adjustable Speed Drive Systems: <http://www.nema.org/stds/acadjustable.cfm#download>

\* This information applies only to Integral Horsepower (IHP) motors as defined on the Agency Approval page, under UL<sup>®</sup> & CSA<sup>®</sup> listings where indicated.

# Warranty Guidelines for Integral Horsepower (IHP)\* Motors on Variable Frequency Drives

## Warranty Guidelines

The information in the following section refers to the motor and drive application guidelines and limitations for warranty.

### Hazardous Location Motors

Use of a variable frequency drive with the motors in this catalog, intended for use in hazardous locations, is only approved for Division 1, Class I, Group D hazardous location motors with a T2B temperature code, with a limitation of 2:1 constant torque or 10:1 variable torque output. **No other stock hazardous location motors are inherently suitable for operation with a variable frequency drive.** If other requirements are needed, including non-listed Division 2, please contact your Nidec Motor Corporation territory manager to conduct an engineering inquiry.

### 575 Volt Motors

575 volt motors can be applied on Inverters when output filters are used. Contact the drive manufacturer for filter selection and installation requirements.

### Applying INVERTER GRADE® Insulated Motors on Variable Frequency Drives (2, 4, 6 pole)

The products within this catalog labeled “Inverter Duty” or “Vector Duty” are considered INVERTER GRADE® insulated motors. INVERTER GRADE® motors exceed the NEMA® MG-1 Part 31 standard. Nidec Motor Corporation provides a three-year limited warranty on all NEMA® frame INVERTER GRADE® insulated motors and allows long cable runs between the motor and the VFD (limited to 400 feet without output filters). Cable distance can be further limited by hot and humid environments and VFD manufacturers cable limits. These motors may be appropriate for certain severe inverter applications or when the factors relating to the end use application are undefined (such as spares).

Nidec Motor Corporation’s U.S. Motors® brand is available in the following INVERTER GRADE® insulated motors:

- Inverter Duty NEMA® frame motors good for 20:1 Variable Torque & 5:1 Constant Torque, including Vertical Type RUSI (10:1 V.T.)
- Inverter Duty motors rated for 20:1 Constant Torque
- ACCU-Torq® and Vector Duty Motors with full torque to 0 Speed or 5000:1
- 841 Plus® NEMA® Frame Motors

### Applying Premium Efficient motors (that do not have INVERTER GRADE® insulation) on Variable Frequency Drives (2, 4, 6 pole)

Premium efficient motors without INVERTER GRADE insulation meet minimum NEMA® MG-1, Section IV, Part 31.4.4.2. These motors can be used with Variable Frequency Drives (with a reduced warranty period) under the following parameters:

- On NEMA® frame 447 and smaller motors, 20:1 speed rating on variable torque loads & 4:1 speed range on constant torque loads.
- On TITAN® 449 and larger frame motors, 10:1 speed rating on variable torque loads.

- On TITAN® frame motors, inquiry required for suitability on constant torque loads.

Cable distances are for reference only and can be further limited by hot and humid environments (refer to Table 1). Refer to specific VFD

Table 1 - Cable Distances			
Maximum Cable Distance VFD to Motor			
Switching Frequency	460 Volt	230 Volt	380 Volt
3 KHz	127 ft	400 ft	218 ft
6 KHz	90 ft	307 ft	154 ft
9 KHz	73 ft	251 ft	126 ft
12 KHz	64 ft	217 ft	109 ft
15 KHz	57 ft	194 ft	98 ft
20 KHz	49 ft	168 ft	85 ft

manufacturers cable limits. Refer to the Motor/ Inverter Compatibility page for special consideration of vertical motor bearings.

## Warranty Period Clarifications and Exceptions

### Standard Energy Efficient Exclusion

Applying Standard & Energy Efficient Motors on Variable Frequency Drives is not recommended. VFD related failures on standard and energy efficient motors will not be covered under warranty.

### Vertical Motor Windings

Premium efficient vertical motors without INVERTER GRADE® insulation that are installed using the criteria described in this document and applied in the correct applications shall have a warranty while powered by a VFD for 12 months from date of installation or 18 months from date of manufacturing whichever comes first. See limited warranty page for horizontal motor warranty periods.

### Bearing Exclusion for Thrust Handling Bearings

Bearings used in premium efficient vertical motors, and all thrust handling bearings, that are powered by VFDs without shaft grounding devices or insulated bearings (when required) will not be covered under any warranty for damages caused from being powered by a VFD. All other bearing failure is covered per NMC’s standard warranty. An electric motor repair shop approved to service U.S. MOTORS® brand motors must verify that the cause of the bearing failure was not due to Electrical Discharge Machining.

### Medium Voltage and Slow Speed Considerations

Motors that are rated above 700 VAC or that are eight pole and slower require special consideration and installation and are not covered under the warranty guidelines in this document. Motors that are rated above 700VAC have special cable length and voltage differential issues that are specific to the VFD type and manufacture. The motor construction and cost may vary dramatically depending on the VFD topology and construction. Contact your NMC representative with VFD manufacturer name and model type for application and motor construction considerations. Motors that are designed eight pole and slower also require special installation and filters per the drive manufacturer.

\* This information applies only to Integral Horsepower (IHP) motors as defined on the Agency Approval page, under UL® & CSA® listings where indicated.

VILLAGE OF NEWTON FALLS, OHIO  
ORDINANCE NO.: 2025-05  
SPONSOR: Councilpersons Axiotis, Stimpert

**AN ORDINANCE RECOGNIZING JACKSON STREET AREAS 44, 45, AND 46 AS PARTS OF AN UNIMPROVED STREET, VACATING AREAS 44, 45, AND 46 OF JACKSON STREET, AND TRANSFERRING THE VACATED SECTIONS TO THE ADJOINING PROPERTY OWNERS**

WHEREAS, The Village has recognized that certain areas of Jackson Street will never be an improved street or connect to Warren Road with any other City Street, and;

WHEREAS, those areas of Jackson Street require regular maintenance, including grass mowing and weed trimming, which represent a cost with no benefit to the Village of Newton Falls, and;

WHEREAS, The Village ordered a survey of the unimproved section of Jackson Street and replatted that section into Vacation Areas 44, 45, and 46 as described and shown within Exhibit A, "Vacation Plat Part of Jackson Street", and;

WHEREAS, the Village Council wishes to vacate areas 44, 45, and 46 of Jackson Street; and

WHEREAS, The Village Council recognizes the expressed interest of the property owners of Homeland Addition Plat lots 44, 45, and 46 in acquiring the vacated area adjacent to their respective properties, and the property owners further agree to maintain their respective section according to City Zoning Requirements.

NOW, THEREFORE, the Council of the Village of Newton Falls, State of Ohio, hereby ordains:

SECTION 1. That the Village Council declares Vacation Areas 44, 45, and 46 of Jackson Street to be unimproved, of no use to the Village of Newton Falls, and hereby vacates said areas.

SECTION 2. That the Village Council transfers ownership of Vacated Areas 44, 45, and 46 of Jackson Street that is immediately adjacent to and directly connected to the property of each of the property owners of Homeland Addition Plat lots 44, 45, and 46 accordingly.

SECTION 3. That the Village Council directs the Interim City Manager to execute the transfer of ownership with any and all costs associated with the transfer of each property to be paid by the property owners of Homeland Addition Plat lots 44, 45, and 46 accordingly.

ORDINANCE NO.: 2025-05

PAGE TWO

SECTION 4. That all formal actions of this Council concerning and relating to the adoption of this Ordinance were taken in an open meeting of this Council, and all deliberations of this Council or any of its committees that resulted in such formal action were taken in meetings open to the public and/or in compliance with all legal requirements, including Section 121.22 of the Ohio Revised Code.

SECTION 5. That this Ordinance shall be effective as of the earliest date permitted by law.

PASSED IN COUNCIL THIS \_\_\_\_\_ DAY OF \_\_\_\_\_, 2025.

\_\_\_\_\_  
David Hanson, Mayor

Attest:

\_\_\_\_\_  
Michael Acomb, Clerk of Council

Approved as to Legal Form.

\_\_\_\_\_  
Jeff Limbian, Law Director





THOMAS FOX & ASSOCIATES, INC.  
3896 MAHONING AVENUE,  
YOUNGSTOWN, OHIO 44515  
330-799-1501

PLAN PREPARED BY:

APPROVED BY THE NEWTON FALLS PLANNING COMMISSION THIS 7 DAY OF January 2025  
CHAIRMAN [Signature] SECRETARY [Signature]  
PASSED ON THIS DAY OF \_\_\_\_\_, 2024,  
CLERK \_\_\_\_\_ MAYOR \_\_\_\_\_  
ENTERED FOR TRANSFER THIS DAY OF \_\_\_\_\_, 2024  
RECEIVED FOR RECORD ON THE DAY OF \_\_\_\_\_, 2024, AT \_\_\_\_\_ O'CLOCK  
PAGE \_\_\_\_\_ OF THE TRUMBULL COUNTY RECORD OF PLATS  
ON THE DAY OF \_\_\_\_\_, 2024

APPROVED BY AND ACCEPTED BY THE COUNCIL OF NEWTON FALLS, THROUGH ORDINANCE NO. \_\_\_\_\_  
TRUMBULL COUNTY AUDITOR \_\_\_\_\_

VACATED RW AREAS =  
PARCEL 44 = 0.044 AC. (1919 S.F.)  
PARCEL 45 = 0.020 AC. (1857 S.F.)  
PARCEL 46 = 0.031 AC. (1349 S.F.)  
TOTAL = 0.095 AC. (4125 S.F.)

I HEREBY CERTIFY, TO THE BEST OF MY KNOWLEDGE AND BELIEF  
THIS PLAT IS A TRUE DELINEATION OF A SURVEY MADE AT THE  
DIRECTION OF NEWTON FALLS BY THOMAS FOX & ASSOCIATES, INC.  
AND THAT ALL MONUMENTS SHOWN ARE IN PLACE.  
FRANKLIN D. SNYDER, JR., P.S. NO. S-7468  
DATE 11/27/2024

Signed [Signature] Date May 17 2025  
Approved by [Signature] Newton Falls Zoning Inspector

LINE AND CURVE TABLE

KEY	DELTA	RADIUS	ARC LENGTH	BEARING	
A	09°40'51"	150.00'	25.34'	25.31'	N56°03'41"W
B	09°40'51"	175.00'	29.57'	29.53'	S56°03'41"E
C	09°40'51"	200.00'	33.79'	33.75'	S56°03'41"E
D			2.62'		S51°13'16"E

Approved by Newton Falls Planning Commission



# VACATION PLAT PART OF JACKSON STREET

PART OF SECTION 2, NEWTON TOWNSHIP  
TOWNSHIP 3, RANGE V, CONNECTICUT WESTERN RESERVE  
CITY OF NEWTON FALLS VILLAGE  
TRUMBULL COUNTY, STATE OF OHIO  
HOMELAND ADDITION, VOL. 10, PG 128  
HOMELAND ADDITION REVISED PLAT OF LOTS, 46-47-57-58, VOL. 10, PG. 130

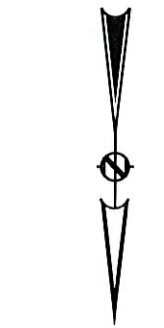
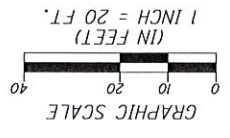
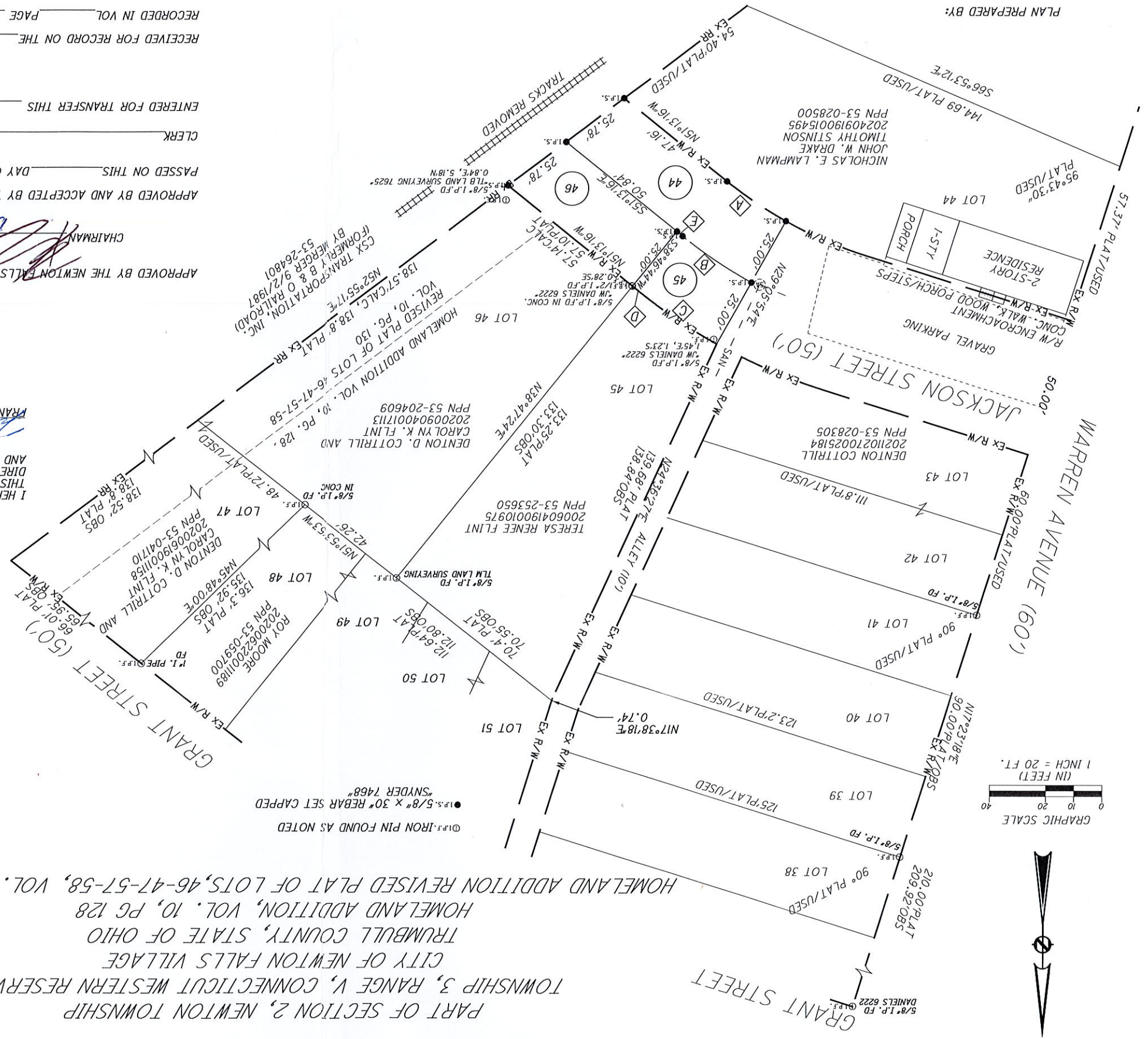

ALL BEARINGS SHOWN ARE FOR PROJECT USE ONLY.  
BEARINGS ARE BASED ON GRID NORTH OF THE OHIO  
DEPARTMENT OF TRANSPORTATION, TRUMBULL COUNTY  
COORDINATE SYSTEM BY GNSS RTN MEASUREMENTS IN  
OCTOBER, 2024.

BASIS FOR BEARINGS:





THOMAS FOK & ASSOCIATES, INC.  
3896 MAHONING AVENUE  
YOUNGSTOWN, OHIO 44515  
330-799-1501

PLAN PREPARED BY:

# VACATION PLAT PART OF JACKSON STREET

PART OF SECTION 2, NEWTON TOWNSHIP  
TOWNSHIP 3, RANGE V, CONNECTICUT WESTERN RESERVE  
CITY OF NEWTON FALLS VILLAGE  
TRUMBULL COUNTY, STATE OF OHIO  
HOMELAND ADDITION, VOL. 10, PG 128  
HOMELAND ADDITION REVISED PLAT OF LOTS, 46-47-57-58, VOL. 10, PG. 130

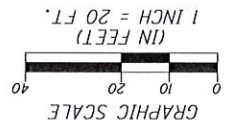
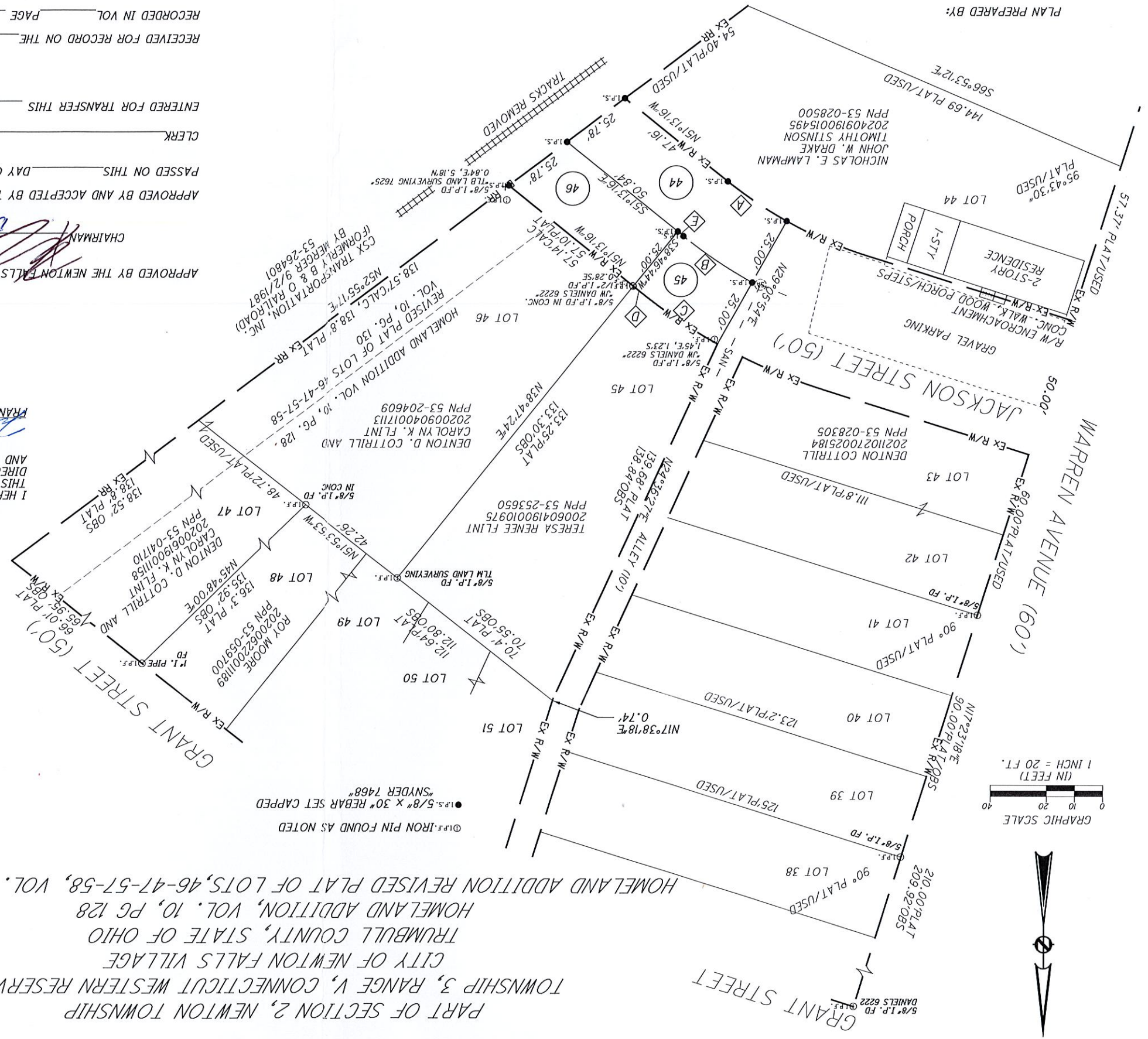

LINE AND CURVE TABLE

KEY	DELTA	RADIUS	ARC LENGTH	BEARING
A	09°40'51"	150.00'	25.34'	N56°03'41"W
B	09°40'51"	175.00'	29.57'	S56°03'41"E
C	09°40'51"	200.00'	33.79'	S56°03'41"E
D			2.62'	S51°13'16"E
Approved by Newton Falls Planning Commission				N51°13'16"W

Approved by *John M. Spellich*  
Newton Falls Zoning Inspector

Signed *John M. Spellich*  
Date *May 17 2025*

I HEREBY CERTIFY, TO THE BEST OF MY KNOWLEDGE AND BELIEF  
THIS PLAT IS A TRUE DELINEATION OF A SURVEY MADE AT THE  
DIRECTION OF NEWTON FALLS BY THOMAS FOK & ASSOCIATES, INC.  
AND THAT ALL MONUMENTS SHOWN ARE IN PLACE.  
FRANKLIN D. SNYDER, JR., P.S. NO. S-7468  
DATE *11/27/2024*



VACATED RW AREAS =  
PARCEL 44 = 0.044 AC. (1919 S.F.)  
PARCEL 45 = 0.020 AC. (857 S.F.)  
PARCEL 46 = 0.031 AC. (1349 S.F.)  
TOTAL = 0.095 AC. (4125 S.F.)

APPROVED BY THE NEWTON FALLS PLANNING COMMISSION THIS *7* DAY OF *January* 2025  
CHAIRMAN *John Snyder*  
SECRETARY *Brian Kopp*

PASSED ON THIS \_\_\_\_\_ DAY OF \_\_\_\_\_, 2024,  
CLERK \_\_\_\_\_  
MAYOR \_\_\_\_\_  
ENTERED FOR TRANSFER THIS \_\_\_\_\_ DAY OF \_\_\_\_\_ 2024  
TRUMBULL COUNTY AUDITOR \_\_\_\_\_  
RECEIVED FOR RECORD ON THE \_\_\_\_\_ DAY OF \_\_\_\_\_, 2024, AT \_\_\_\_\_ O'CLOCK  
PAGE \_\_\_\_\_ OF THE TRUMBULL COUNTY RECORD OF PLATS  
ON THE \_\_\_\_\_ DAY OF \_\_\_\_\_, 2024,  
TRUMBULL COUNTY RECORDER \_\_\_\_\_

BASIS FOR BEARINGS:  
ALL BEARINGS SHOWN ARE FOR PROJECT USE ONLY.  
DEPARTMENT OF TRANSPORTATION, TRUMBULL COUNTY  
COORDINATE SYSTEM BY GNSS RTN MEASUREMENTS IN  
OCTOBER, 2024.

### Description of Jackson Street Vacation Area 44

Situate in the State of Ohio, County of Trumbull, Village of the City of Newton Falls, in Section 2 of original Newton Township, Township 3, Range V of the Connecticut Western Reserve and being part of Jackson Street, 50.00 feet wide, as dedicated by the Homeland Addition plat recorded in volume 10, page 128 of the Trumbull County Recorder's Office and further described as follows:

Beginning at an iron pin set at the northeasterly corner of lot 44 of the Homeland Addition plat, also being the southeasterly limit of Jackson Street and the northwesterly line of the CSX Transportation, Inc. (formerly B & O Railroad) land;

Thence along the northerly line of lot 44 and the southerly right of way line of Jackson Street, **North 51 degrees, 13 minutes, 16 seconds West, 47.16 feet** to an iron pin set at a point of curvature;

Thence continuing along the northerly line of lot 44 and the southerly right of way line of Jackson Street, along the arc of a curve deflecting to the left, **25.34 feet** to an iron pin set where a line drawn normal to the southerly right of way line of Jackson Street, from the intersection of the northerly right of way line of Jackson Street with the easterly line of a 10.00 feet wide alley dedicated by the Homeland Addition plat at the southwesterly corner of lot 45, intersects the southerly right of way line of Jackson Street, said curve having a **radius 150.00 feet, a delta of 09 degrees, 40 minutes, 51 seconds, and a chord of 25.31 feet which bears North 56 degrees, 03 minutes, 41 seconds West;**

Thence along a line normal to the centerline of Jackson Street, **North 29 degrees, 05 minutes, 54 seconds East, 25.00 feet** to an iron pin set in the centerline of Jackson Street;

Thence along the centerline of Jackson Street, along the arc of a non-tangential curve deflecting to the right, **29.57 feet** to an iron pin set at a point of tangency, said curve having a **radius of 175.00 feet, a delta of 09 degrees, 40 minutes, 51 seconds, and a chord of 29.53 feet which bears South 56 degrees, 03 minutes, 41 seconds East;**

Thence continuing along the centerline of Jackson Street, **South 51 degrees, 13 minutes, 16 second East,** at 2.62 feet passing through an iron pin set, a total distance of **53.46 feet** to an iron pin set in the northwesterly line of the CSX Transportation Inc.'s land at the easterly limit of Jackson Street;

Thence along the easterly limit of Jackson Street and the northwesterly line of the CSX Transportation Inc.'s land, **South 52 minutes, 55 seconds, 17 seconds West, 25.78 feet** to the place of beginning and containing 0.044 acres (1919 S.F.) of land, more or less, as surveyed and described in November 2024 by Thomas Fok & Associates, Inc. under the supervision of Franklin D. Snyder, Jr., PS Ohio# S-7468.



Intending to describe that southerly portion of Jackson Street to be vacated which is located easterly of the 10.00 feet wide alley by a line extended normal to the southerly right of way line of Jackson Street and along northerly boundary of lot 44 of the Homeland Addition plat.

The bearings used herein are relative to grid north of the Ohio Department of Transportation, Trumbull County Coordinate System, with a bearing of North 38 degrees, 47 minutes, 24 seconds East along the line between lot 45 and lot 46 of the Homeland Addition plat. All iron pins described as set are 5/8-inch rebars set 30-inches deep with a yellow plastic cap embossed "SNYDER 7468".

*Franklin D. Snyder, Jr. P.S.*  
11/27/2024





# Deed Runner Printout

11-27-2024 13:47:47

FileName: C:\Program Files (x86)\DeedRunner 3 SL\Untitled.txt  
 Grantor: AREA 44  
 Grantee:  
 Date: 11/27/24  
 Deed Book:  
 Page Number:  
 County: TRUMBULL  
 State:

### Description

LINE NUM	BEARING	DISTANCE(FT)	RADIUS(FT)	ARC LENGTH(FT)
1	N 51°13'16" W	47.160	0.000	0.000
2	N 56°03'41" W	25.310	150.000	25.340
3	N 29°05'54" E	25.000	0.000	0.000
4	S 56°03'41" E	29.530	175.000	29.570
5	S 51°13'16" E	53.460	0.000	0.000
6	S 52°55'17" W	25.780	0.000	0.000

Closure: 0 Feet(0.001Meters)  
 Precision: 1 : 79716.36  
 Delta North: 0.000 Feet(0.000Meters)  
 Delta East: -0.003 Feet(-0.001Meters)  
 Error Bearing: N 85°27'49" W  
 Chord Area: 0.0446 Acres (1940.81 Square Feet) (0.0178 Hectares)  
 Perimeter: 206.31 Feet (62.883Meters)  
 Total Area: 0.0441 Acres (1919.08 Square Feet) (0.0178 Hectares)

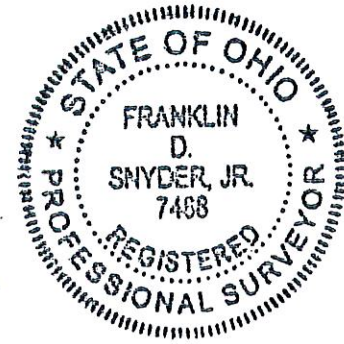

*Franklin D. Snyder, Jr.*  
11/27/2024

### Description of Jackson Street Vacation Area 45

Situate in the State of Ohio, County of Trumbull, Village of the City of Newton Falls, in Section 2 of original Newton Township, Township 3, Range V of the Connecticut Western Reserve and being part of Jackson Street, 50.00 feet wide, as dedicated by the Homeland Addition plat recoded in volume 10, page 128 of the Trumbull County Recorder's Office and further described as follows:

Beginning at the southwesterly corner of lot 45 of the Homeland Addition, also being the intersection of the northerly right of way line of Jackson Street with the easterly line of the 10.00 feet wide alley dedicated by the Homeland Addition plat, said point being referenced by a 5/8 inch iron pin found 1.45 feet east and 1.23 feet south, capped JW Daniels 6222;

Thence along the southerly line of lot 45, also being the northerly right of way line of Jackson Street and along the arc of a non-tangential curve deflecting to the right, **33.79 feet** to a point of tangency, said curve having a **radius of 200.00 feet, a delta of 09 degrees, 40 minutes, 51 seconds, and a chord of 33.75 feet which bears South 56 degrees, 03 minutes, 41 seconds East;**

Thence continuing along the southerly line of lot 45 and the northerly right of way line of Jackson Street, **South 51 degrees, 13 minutes, 16 seconds East, 2.62 feet** to a 5/8 inch iron pin found in concrete, capped JW Daniels 6222, at the southwesterly corner of lot 46, also being the southeasterly corner of lot 45, with a 1/2 inch iron pin found 0.28 feet southeast;

Thence normal to the centerline of Jackson Street, **South 38 degrees, 46 minutes, 44 seconds West, 25.00 feet** to an iron pin set on the centerline of Jackson Street;

Thence along the centerline of Jackson Street, **North 51 degrees, 13 minutes 16 seconds West, 2.62 feet** to an iron pin set at a point of curvature;

Thence along the arc of a curve deflecting to the left, **29.57 feet** to an iron pin set at the intersection with a line drawn normal to the centerline of Jackson Street, from the intersection of the northerly right of way line of Jackson Street with the easterly line of the 10.00 feet wide alley dedicated by the Homeland Addition plat, said curve having a **radius 175.00 feet, a delta of 09 degrees, 40 minutes, 51 seconds, and an chord of 29.53 feet which bears North 56 degrees, 03 minutes, 41 seconds West;**

Thence along a line normal to the northerly right of way line of Jackson Street, **North 29 degrees, 05 minutes, 54 seconds East, 25.00 feet** to the place of beginning and containing 0.020 acres (857 S.F.) of land, more or less, as surveyed and described in November 2024 by Thomas Fok & Associates, Inc. under the supervision of Franklin D. Snyder, Jr., PS Ohio# S-7468.

Intending to describe that northerly portion of Jackson Street to be vacated which is located easterly of the 10.00 feet wide alley and along the southerly boundary of lot 45 of the Homeland Addition plat.

The bearings used herein are relative to grid north of the Ohio Department of Transportation, Trumbull County Coordinate System, with a bearing of North 38 degrees, 47 minutes, 24 seconds East along the line between lot 45 and lot 46 of the Homeland Addition plat. All iron pins described as set are 5/8-inch rebars set 30-inches deep with a yellow plastic cap embossed "SNYDER 7468".

*Franklin D. Snyder, Jr. P.S.*  
11/27/2024



# Deed Runner Printout

11-27-2024 14:08:06

FileName: C:\Program Files (x86)\DeedRunner 3 SL\UNTITLED.TXT  
 Grantor: AREA 45  
 Grantee:  
 Date: 11/27/24  
 Deed Book:  
 Page Number:  
 County: TRUMBULL  
 State:

### Description

LINE NUM	BEARING	DISTANCE(FT)	RADIUS(FT)	ARC LENGTH(FT)
1	S 56°03'41" E	33.750	200.000	33.790
2	S 51°13'16" E	2.620	0.000	0.000
3	S 38°46'44" W	25.000	0.000	0.000
4	N 51°13'16" W	2.620	0.000	0.000
5	N 56°03'41" W	29.530	175.000	29.570
6	N 29°05'54" E	25.000	0.000	0.000

Closure: 0 Feet(0.000Meters)  
 Precision: 1 : 109495.39  
 Delta North: 0.001 Feet(0.000Meters)  
 Delta East: -0.001 Feet(0.000Meters)  
 Error Bearing: N 56°03'41" W  
 Chord Area: 0.0196 Acres (853.68 Square Feet) (0.0080 Hectares)  
 Perimeter: 118.60 Feet (36.149Meters)  
 Total Area: 0.0197 Acres (857.00 Square Feet) (0.0080 Hectares)

*Franklin D. Snyder, P.S.*  
11/27/2024

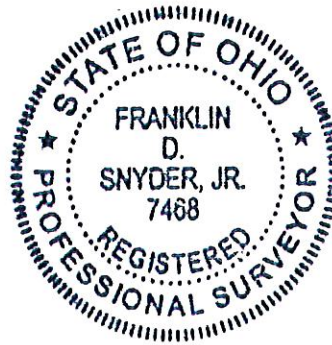

### Description of Jackson Street Vacation Area 46

Situate in the State of Ohio, County of Trumbull, Village of the City of Newton Falls, in Section 2 of original Newton Township, Township 3, Range V of the Connecticut Western Reserve and being part of Jackson Street, 50.00 feet wide, as dedicated in the Homeland Addition plat recorded in volume 10, page 128 of the Trumbull County Recorder's Office and further described as follows:

Beginning at an iron pin set at the southeasterly corner of lot 46 of the Revised Plat of Lots 46-47-57-58 and Alley Abutting Lots 46, 47, 57, 58 as recorded in volume 10, page 130 of the Trumbull County Recorder's Office, also being the southeasterly limit of Jackson Street as dedicated in the Homeland Addition plat and the northwesterly line of the CSX Transportation, Inc.'s (formerly B & O Railroad) land, witnessed by a 5/8 inch iron pin found, 1.2 feet tall, 0.84 feet east, 5.18 feet north, capped TLB Land Surveying 7625;

Thence along the easterly limit of Jackson Street and the northwesterly line of the CSX Transportation Inc.'s land, **South 52 minutes, 55 seconds, 17 seconds West, 25.78 feet** to an iron pin set at the centerline of Jackson Street;

Thence along the centerline of Jackson Street, **North 51 degrees, 13 minutes, 16 seconds West 50.84 feet** to an iron pin set;

Thence normal to the northerly right of way line of Jackson Street, **North 38 minutes, 46 seconds, 44 seconds East, 25.00 feet** to a 5/8 inch iron pin found in concrete, capped JW Daniels 6222, at the southeasterly corner of lot 45, also being the southwesterly corner of lot 46, with a 1/2 inch iron pin found 0.28 feet southeast;

Thence along the southerly line of lot 46, also being the northerly right of way line of Jackson Street, **South 51 degrees, 13 minutes, 16 seconds East, 57.14 feet** to the place of beginning and containing 0.020 acres (1349 S.F.) of land, more or less, as surveyed and described in November 2024 by Thomas Fok & Associates, Inc. under the supervision of Franklin D. Snyder, Jr., PS Ohio# S-7468.

Intending to describe that northerly portion of Jackson Street to be vacated which is along the southerly boundary of lot 46 of the Homeland Addition plat and the Revised Plat of Lots 46-47-57-58 and Alley Abutting Lots 46, 47, 57, 58.

The bearings used herein are relative to grid north of the Ohio Department of Transportation, Trumbull County Coordinate System, with a bearing of North 38 degrees, 47 minutes, 24 seconds East along the line between lot 45 and lot 46 of the Homeland Addition plat. All iron pins described as set are 5/8-inch rebars set 30-inches deep with a yellow plastic cap embossed "SNYDER 7468".

*Franklin D. Snyder, Jr. P.S.*  
11/27/2024

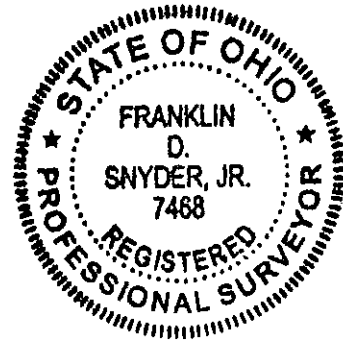

# Deed Runner Printout

-27-2024 14:43:40

eName: C:\Program Files (x86)\DeedRunner 3 SL\Untitled.txt  
 antor: AREA 46  
 antee:  
 ite: 11/27/24  
 ed Book:  
 ige Number:  
 unty: TRUMBULL  
 ate:

### Description

VE NUM	BEARING	DISTANCE(FT)	RADIUS(FT)	ARC LENGTH(FT)
1	S 52°55'17" W	25.780	0.000	0.000
2	N 51°13'16" W	50.840	0.000	0.000
3	N 38°46'44" E	25.000	0.000	0.000
4	S 51°13'16" E	57.140	0.000	0.000

osure: 0 Feet(0.001Meters)  
 ecision: 1 : 91861.20  
 lta North: 0.000 Feet(0.000Meters)  
 lta East: -0.002 Feet(-0.001Meters)  
 or Bearing: S 76°36'58" W  
 ord Area: 0.0310 Acres (1349.70 Square Feet) (0.0125 Hectares)  
 rimeter: 158.76 Feet (48.390Meters)  
 tal Area: 0.0310 Acres (1349.70 Square Feet) (0.0125 Hectares)

*Franklin D. Snyder, Jr.*  
 11/27/2024



VILLAGE OF NEWTON FALLS, OHIO  
ORDINANCE NO.: 2025-06  
SPONSORS: Councilpersons Axiotis, Rufener

**AN ORDINANCE AUTHORIZING THE INTERIM CITY MANAGER TO ENTER INTO AN AGREEMENT TO AMEND THE COMPENSATION PROVISIONS OF THE INVESTMENT MANAGEMENT AGREEMENT BETWEEN THE VILLAGE AND MEEDER PUBLIC FUNDS, INC.**

WHEREAS, on or about December 21, 2021, The Village of Newton Falls (Village) and Meeder Public Funds, Inc. (Meeder) entered into an Investment Management Agreement (Exhibit A) in which Meeder committed to provide investment management services to the Village; and

WHEREAS, Meeder and the Village wish to amend the Agreement relating to the compensation provisions of the Investment Management Agreement.

NOW, THEREFORE, the Council of the Village of Newton Falls, State of Ohio, hereby ordains:

SECTION 1. That Council hereby authorizes the Interim City Manager to enter into the attached Amendment to the Investment Management Agreement (Exhibit B).

SECTION 2. That all formal actions of this Council concerning and relating to the adoption of this Ordinance were taken in an open meeting of this Council, and all deliberations of this Council or any of its committees that resulted in such formal action were taken in meetings open to the public and/or in compliance with all legal requirements, including Section 121.22 of the Ohio Revised Code.

SECTION 3. That this Ordinance shall be effective as of the earliest date permitted by law.

PASSED IN COUNCIL THIS \_\_\_\_\_ DAY OF MARCH, 2025

\_\_\_\_\_  
David Hanson, Mayor

Attest:

\_\_\_\_\_  
Michael Acomb, Clerk of Council

Approved as to Legal Form.

\_\_\_\_\_  
Jeff Limbian, Law Director



# Investment Management Agreement

## Meeder Public Funds

This Investment Management Agreement ("Agreement") is effective as of the date executed by and between Meeder Public Funds, Inc. ("Meeder"), its applicable affiliates, and the undersigned account owner ("Client").

1. **Investment Management Services.** Under this Agreement, Meeder provides discretionary investment management services for public entity clients in accordance with the terms of the applicable state investment code and investment policy.

2. **Appointment.** Client appoints Meeder as discretionary investment manager to manage the assets deposited in any account subject to the terms of this Agreement ("Account"). Meeder accepts the appointment as investment manager and shall invest, reinvest and manage the securities, cash and other assets of the Account subject to any Investment Policy Statement provided by Client. Meeder shall provide advice only with respect to assets in the Account and shall have no responsibility for the actions or non-actions of predecessor investment advisors or for the management of assets other than the assets allocated to the Account.

3. **Trading Authorization.** Client grants Meeder discretionary trading authority and appoints Meeder as agent and attorney-in-fact with respect to investments in the Account. Meeder may direct the purchase, sale, exchange, conversion, delivery or other acquisition or disposition of securities and other investments in the Account and act on behalf of Client in all other matters incidental to the handling of Account investments, all without prior consultation with Client.

4. **Custody.** Meeder will not assume physical custody of the Account or any portion of it. Client shall establish a custodial account with a qualified custodian ("Custodian"). Client will receive from the Custodian account statements and confirmations identifying assets and transactions in the Account. All transactions will be consummated by payment to, or delivery by, the Custodian of all cash, securities and other assets due to or from the Account. The Custodian shall be responsible for investing any daily cash balances in the Account and Meeder will not exercise discretion to select sweep vehicles for the Account.

5. **Investment Objectives and Restrictions.** Client may provide Meeder with an Investment Policy Statement or other written directions setting forth the investment objectives and any specific investment restrictions or limitations which govern the Account. Meeder shall be entitled to rely on such guidelines, objectives and restrictions relating to the Account as it may receive from Client. It is Client's responsibility to inform Meeder in writing of any changes or modifications to the Investment Guidelines, which shall be given ten days in advance of any such change.

6. **Brokerage.** Unless otherwise directed, Meeder will place trades for the Account through such brokers or dealers as it may select. When selecting brokers, Meeder's primary consideration will be the broker's ability to provide best execution of trades and Meeder may consider the quality and reliability of the brokerage services, trade price and commission, as well as research and other services provided by the broker-dealers.

7. **Trade Aggregation.** Meeder may aggregate trades for multiple clients when, in the adviser's judgment, aggregation is in the best interests of the clients involved. Orders are aggregated to facilitate best execution and allocate equitably among clients the effects of any market fluctuations that might have otherwise occurred had these orders been placed independently. Where it is not possible to obtain the same execution price for all securities purchased or sold on an aggregated basis, Meeder may allocate trades equitably among its clients using the average execution price.



8. **Fees.** For the services provided in accordance with this Agreement, Client will pay an investment advisory fee as indicated on Schedule A to this Agreement. Investment advisory fees do not include custody fees charged by Client's selected Custodian. Where Client has elected to have fees deducted, Client authorizes the Custodian to deduct fees from the Account and pay them to Meeder.

9. **Solicitor Arrangements.** Meeder accepts Clients referred through unaffiliated introducing advisors ("Solicitors") and Meeder Public Funds, Inc. may pay a referral fee directly or through its affiliate, Meeder Advisory Services, Inc., in connection with Client's Account. Each Client who is introduced to Meeder by a Solicitor will acknowledge the amount of the referral fee in a separate Written Disclosure Statement.

10. **Third-Party Payments.** Meeder or its affiliates receive compensation from unaffiliated third parties for opening, administering or advising certain financial products offered to advisory clients, including STAR Ohio and the Government Insured Deposit Program (GIDP). Asset based advisory fees are not charged for assets invested in products that pay indirect compensation to Meeder.

11. **Proxy Voting.** Meeder does not accept or assume authority to vote proxies for its public fund clients. Clients will receive their proxies or other solicitations directly from their Custodian. Client agrees that Meeder will not advise or act for Client in any legal proceedings, including bankruptcies or class actions, involving securities held or previously held by the Account or the issuers of such securities.

12. **Electronic Delivery.** Client consents to electronic delivery of all documents from Meeder, including but not limited to a copy of the executed Agreement, statements, confirmations, Meeder's Form ADV Part 2, and other general communications.

13. **Confidentiality.** All information and advice furnished by either party to the other, including their respective agents and employees, shall be treated as confidential and shall not be disclosed to third parties except as otherwise required by law or as agreed to in writing by Client. Notwithstanding the foregoing, Client consents to the use of Client's name in sales and marketing material used by Meeder or its affiliates solely for the purpose of identifying the Client as an investment advisory client.

14. **Services to Other Clients.** Client understands that Meeder serves as investment adviser for other clients and will continue to do so. Client also understands that Meeder, its personnel and affiliates ("Affiliated Persons") may give advice or take action in performing their duties to other clients, or for their own accounts, that differ from advice given to or action taken for Client. Meeder is not obligated to buy, sell or recommend for Client any security or other investment that Meeder or its Affiliated Persons may buy, sell or recommend for any other client or their own accounts.

15. **Meeder's Representations.** Meeder represents that it is a registered investment adviser under the Investment Advisers Act of 1940.

16. **Client's Representations.** Client represents and acknowledges that: (i) Client is the sole owner of the Account assets and has full power and authority to enter into this Agreement and to commit the assets to Meeder's management and supervision; (ii) that the person signing this Agreement on behalf of Client is authorized and empowered to establish accounts and commit the assets to Meeder's management and supervision on the entity's behalf; (iii) Client has received Meeder's current Form ADV, Part 2A and B; and (iv) Client has received a copy of Meeder's Privacy Policy.

17. **Term.** This Agreement may be terminated by either party for any or no reason upon delivery by first class U.S. mail, postage prepaid, or delivery by hand, of a written "Notice of Termination" to the other party at least thirty (30) days prior to the date of the intended early termination of this Agreement. Termination of this Agreement will not affect the status, obligations or liabilities of the parties to this Agreement that arose prior to such termination.

18. **Limitation of Liability.** Except for negligence, malfeasance or violation of applicable law, neither Meeder nor its officers, directors or employees shall be liable to Client for any action performed, or omitted to be performed, or for any errors of judgment in managing the Account. Nor shall Meeder be liable to Client for any act or failure to

act by any other third party. The federal securities laws impose liabilities under certain circumstances on persons even when they act in good faith. Therefore, nothing in this Agreement shall in any way constitute a waiver or limitation of any rights that Client may have under any federal or state securities laws.

19. **Assignment.** This Agreement may not be assigned by either party without the consent of the other party. Meeder will provide Client at least thirty (30) days prior written notice of any proposed assignment, and Client's consent will be presumed unless Client notifies Meeder otherwise in writing prior to the date of the assignment indicated on the notice.

20. **Amendment.** This Agreement may be amended by Meeder with thirty (30) days prior written notice to Client and may be amended immediately upon notice to the extent reasonably required to satisfy federal or state regulatory requirements.

21. **Governing Law.** This Agreement will be governed by and construed in accordance with the laws of the State of Ohio without giving effect to any conflict or choice of law provisions of that State.

22. **Severability.** If any provision of this Agreement is or should become inconsistent with any law or rule of any governmental or regulatory body having jurisdiction over the subject matter of this Agreement, the provision will be deemed to be rescinded or modified in accordance with any such law or rule. In all other respects, this Agreement will continue and remain in full force and effect.

23. **Affiliates.** To the extent necessary to carry out the terms of this Agreement, any named affiliate of Meeder shall be deemed to be a party to the Agreement for that purpose.

IN WITNESS WHEREOF, the parties have caused this Agreement to be executed by their duly authorized officers or agents to become effective as of the day and year first written above.

MEEDER PUBLIC FUNDS, Inc.

CITY OF NEWTON FALLS

Jason Headings

Sr. Vice President

TITLE

SIGNATURE

DATE

*Jason Headings*  
12/22/21

TITLE

SIGNATURE

DATE

*City Manager*  
*James Sweeney*  
12/24/21





# Meeder Public Funds

## Schedule of Fees

### Asset Based Fee

This schedule sets forth the standard annual investment advisory fee applicable to the Account under this Agreement. The schedule is tiered and each tier of assets under management will be assessed at the rate set forth in the schedule.

Operating Funds	
Assets Under Management	Annual Advisory Fee
Up to \$25,000,000	0.10%
\$25,000,000 - \$50,000,000	0.08%
\$50,000,000 - \$100,000,000	0.06%
Over \$100,000,000	0.04%

Project Funds	
Assets Under Management	Annual Advisory Fee
First \$50 million	0.06%
Over \$50 million	0.04%

Investment advisory fees are subject to minimum fee of \$5,000 per year. Fees are calculated and billed monthly in arrears based on the value of the securities, cash and other assets in the account at the end of the billing period. Unless otherwise agreed, fees are deducted directly from the Account. For clients who utilize Meeder's Preferred Custodian, fees may be credited an amount equal to the custodial fee up to a maximum annual credit of 0.01%. Meeder reserves the right to discontinue credits for custodial fees charged by the Preferred Custodian at any time and upon 30 days' notice in writing of the change to Client.



# **AMENDMENT TO INVESTMENT MANAGEMENT AGREEMENT**

Meeder Public Funds

This Amendment to the Investment Management Agreement is effective as of May 1, 2025 (“Effective Date”), by and between City of Newton Falls (“Client”) and Meeder Public Funds, Inc. (“Meeder”).

**WHEREAS**, on or about December 21, 2021, Client and Meeder entered into an Investment Management Agreement (the “Agreement”) in which Meeder committed to provide investment management services to Client; and

**WHEREAS**, Meeder and Client wish to amend the Agreement relating to the compensation provisions of the Agreement.

**NOW THEREFORE**, in consideration of the mutual covenants, promises, conditions and terms to be kept and performed, Client and Meeder mutually agree as follows:

1. The fee schedule as indicated in the Fee section of the Agreement is amended to a minimum fee of \$7,500.
2. All other terms, conditions, and provisions of the Agreement shall remain in full force and effect; provided, however, that any other provision of the Agreement shall be deemed modified as necessary to give practical effect to the provisions of this Agreement.

IN WITNESS WHEREOF, the parties have caused this Agreement to be executed by their duly authorized officers or agents to become effective as of the Effective Date.

**MEEDER PUBLIC FUNDS, INC.**

**CITY OF NEWTON FALLS**

By: \_\_\_\_\_

By: \_\_\_\_\_

Name: \_\_\_\_\_

Name: \_\_\_\_\_

Title: \_\_\_\_\_

Title: \_\_\_\_\_