



NEWTON FALLS CITY COUNCIL
REGULAR MEETING AGENDA
 Wednesday, January 22, 2025; 6:00 PM
 COUNCIL CHAMBERS
 612 WEST BROAD STREET

CITY COUNCIL MEMBERS	
Ward 1	Patricia Benetis
Ward 2	Brian Axiotis
Ward 3	VACANT
Ward 4	Kevin Rufener
At- Large	Julie Stimpert
Mayor	David Hanson

CITY ADMINISTRATION	
Interim City Manager	Mike Novotny
Law Director	Jeff Limbian
Finance Director	Jamie Vernaccini
Clerk of Council	Michael Acomb

- I. Call to Order**
- II. Pledge of Allegiance / Silent Prayer**
- III. Roll Call**
- IV. Changes To Tonight's Agenda**
- V. Special Presentations by Staff Members or Invited Consultants**
- VI. Public Comments (Agenda Items Only)**
- VII. Reports**
 - a. Mayor
 - b. Council Members
 - c. Law Director
 - d. Finance Director
 - e. City Manager
- VIII. Approval of Previous Minutes**
 - Organizational Meeting Minutes January 6, 2025
 - Regular Meeting Minutes January 6, 2025
- IX. Public Hearings**
- X. Unfinished Business**
- XI. New Business**
 - ORDINANCE 2025-01 *Sponsors: Councilpersons Axiotis, Rufener*
 - AN ORDINANCE AUTHORIZING THE INTERIM CITY MANAGER TO ENTER INTO AN AGREEMENT TO PURCHASE AND INSTALL A REPLACEMENT RAW WATER PUMP FOR THE WATER PLANT
- XII. Public Comments**
- XIII. Closing Remarks**
 - a. Mayor
 - b. Council Members
 - c. Finance Director
 - d. Law Director
 - e. City Manager
- XIV. Motion to Recess into Executive Session (If Necessary)**
- XV. Adjournment**



NEWTON FALLS CITY COUNCIL
ORGANIZATIONAL MEETING MINUTES
 Monday, January 06, 2025; 6:00 PM
 COUNCIL CHAMBERS
 612 WEST BROAD STREET

CITY COUNCIL MEMBERS	
Ward 1	Patricia Benetis
Ward 2	Brian Axiotis
Ward 3	VACANT
Ward 4	Kevin Rufener
At- Large	Julie Stimpert
Mayor	David Hanson

CITY ADMINISTRATION	
Interim City Manager	Mike Novotny
Law Director	Jeff Limbian
Finance Director	Jamie Vernaccini
City Clerk	Michael Acomb

- I. Call to Order**
 Mayor Hanson called the meeting to order at 6:03 pm.
- II. Pledge of Allegiance / Silent Prayer**
- III. Roll Call**
 Mayor Hanson asked Mr. Acomb to call the roll.
 Council Present: Councilperson Axiotis, Councilperson Benetis, Councilperson Rufener, Councilperson Stimpert, Mayor Hanson.
 Council Absent: None.
 Staff Present: Interim City Manager Novotny. Clerk Acomb, Law Director Limbian, Finance Director Vernaccini.
 Staff Absent: None.
- IV. Public Comments (Agenda Items Only)**
 None.
- V. New Business**
Appointment of a member of Council to the position of Vice President of Council
 Mayor Hanson called for motion to appoint a member of Council to the position of Vice President of Council. Ms. Benetis made a motion to appoint Ms. Stimpert. Seconded by Mr. Axiotis.
 No discussion.
 Roll Call Vote: Mr. Axiotis-yes; Ms. Benetis-yes; Mr. Rufener-yes; Ms. Stimpert-yes. The motion passed 4-0.

Appointments of members of Council to the open seats on Commissions, Boards, Council Standing Committees, and Community Boards, Committees, and or Commissions.
 Mr. Rufener made a motion to add to the discussion the including of the NF Area Commerce Association. Seconded by Ms. Stimpert.
 Mr. Rufener recommended a discussion of adding a member of council to attend these meetings. NF pays dues and has a vote on their committee. They meet on the first and third Tuesday of each month, at 8:00 am and 6:00 pm, respectively.

Ms. Stimpert clarified that Council would need a motion to add standing committee. Mr. Axiotis asked if anyone knew why it ceased being a committee. No one knew. Mr. Axiotis asked if this already exists or if it needs to be created. Mr. Rufener stated belief that it already exists.

Mr. Rufener made a motion to suspend Council Rules to allow for more discussion. Seconded by Ms. Stimpert.

No discussion.

Roll Call Vote: Mr. Axiotis-yes; Ms. Benetis-yes; Mr. Rufener-yes; Ms. Stimpert-yes. The motion passed 4-0. Council rules were suspended.

Ms. Stimpert asked for clarification. Mr. Rufener said he wants to add it to the list of standing committees and assign member of Council to it that someone always goes to the meetings. Mayor Hanson stated preference to have it rotated among council members. Mr. Axiotis asked if the Economic Development person should be the person to attend those meetings. Ms. Stimpert stated belief that if you're on Economic Development then you should go to these meetings because they seem to go hand in hand. Mayor Hanson stated that Council should represent itself to local businesses and should have someone go to at least one of the meetings each month. Ms. Stimpert expressed concern that a voting seat of this organization needs to be someone consistent because a voting seat is different than a representative seat. Mr. Rufener advocated for a separate committee that is formally recognized. Mayor Hanson asked Mr. Limbian to comment. Mr. Limbian did not comment immediately. Mr. Novotny stated that no dues are paid. Mayor Hanson advocated for waiving Council's vote. Mr. Limbian advocated for the issue to be tabled to allow for proper consideration. Mayor Hanson worried about conflicts of interest with Council having a vote. Ms. Stimpert advocated for keeping the vote. Mr. Limbian asked for time to structure this new role for Council properly before it is voted on.

Mr. Rufener withdrew his primary motion. He also stated that the vote in this organization is usually just to approve previous minutes. The meetings are mostly discussion that would benefit Council. He repeated that the motion was withdrawn.

Mr. Rufener made a Motion to resume Council Rules. Seconded by Mr. Axiotis.

No discussion.

Roll Call Vote: Mr. Axiotis-yes; Ms. Benetis-yes; Mr. Rufener-yes; Ms. Stimpert-yes. The motion passed 4-0. Council rules were resumed.

Ms. Stimpert made a Motion to suspend Council Rules to discuss the next open committee seat. Seconded by Mr. Rufener.

No discussion.

Roll Call Vote: Mr. Axiotis-yes; Ms. Benetis-yes; Mr. Rufener-yes; Ms. Stimpert-yes. The motion passed 4-0. Council rules were suspended.

The council engaged in a mixed discussion in which each of the commissions, boards, and/or committees were discussed. Each one was discussed individually with Council recognizing the current assignments. It was suggested and agreed upon with consent of all members of Council that all assignments would remain the same as in 2024, except for Ms. Stimpert replacing Ms. Persino on the Police Services Committee. Mr. Limbian agreed when asked that Ms. Persino's place on each of the commissions/committees could remain vacant until someone else is appointed to the Ward 3 seat on Council and that the alternate representative of council should attend those meetings until a new member of Council is appointed. Once appointed, that new person would be assumed the

vacant seats on Civil Service, Parks and Recreation, and the Fire District Board (alternate). Ms. Stimpert raised the idea of possibly dissolving the Police Services Community. Mr. Rufener advised against it given the current state of the department.

Ms. Stimpert made a Motion to resume Council Rules. Seconded by Mr. Axiotis.
No discussion.

Roll Call Vote: Mr. Axiotis-yes; Ms. Benetis-yes; Mr. Rufener-yes; Ms. Stimpert-yes. The motion passed 4-0.

Ms. Stimpert made a Motion to approve the committee assignments as recorded by Mr. Acomb during the discussion. Seconded by Mr. Axiotis.

Mr. Acomb read the names of those members who were assigned as the Representative and the Alternate Representative for each commission or committee (Enclosed). When asked by Council, Mr. Acomb also clarified that the Police Services Committee is not an ad-hoc committee; but rather a permanent committee until Council determines the time to dissolve the committee altogether.

Roll Call Vote: Mr. Axiotis-yes; Ms. Benetis-yes; Mr. Rufener-yes; Ms. Stimpert-yes. The motion passed 4-0.

VI. Public Comments

None.

VII. Motion to Recess into Executive Session (If Necessary)

VIII. Adjournment

Mayor Hanson called for a motion to adjourn the meeting. Moved by Ms. Benetis. Seconded by Mr. Axiotis.

No discussion.

Roll Call Vote: Mr. Axiotis-yes; Ms. Benetis-yes; Mr. Rufener-yes; Ms. Stimpert-yes. The motion passed 4-0. The meeting was adjourned at 6:36 pm.

APPROVED:

David Hanson, Mayor

ATTEST:

Michael Acomb, Clerk of Council

Exhibit A
01/06/25 for Calendar Year 2025
As Amended by Council at the 2025 Organizational Meeting

Council Representatives to Commissions and Boards

	<i>Rep</i>	<i>Alt</i>	
<u>Planning and Zoning:</u>	<i>Axiotis</i>	<i>Rufener</i>	
	Meetings: 6:00 pm every 1st Tuesday as needed		
<u>Civil Service:</u>	VACANT	<i>Rufener</i>	
	Meetings: As Needed		
<u>Parks and Recreation:</u>	VACANT	<i>Benetis</i>	
	Meetings: 6:00 pm every 4th Tuesday		
<u>Treasury Investment Board:</u>	<i>Axiotis</i>	<i>x</i>	Finance Director
	S Kropp	Resident	City Manager
	Meetings: Quarterly		
<u>Fire District Board:</u>	<i>Stimpert</i>	VACANT	

Council Standing Committees
Two (2) Council Representatives per Committee

<u>Finance/Administration/Audit:</u>	<i>Axiotis</i>	<i>Rufener</i>	
	(Chair must be on TIB per Charter Article VI, Section 4)		
<u>Utilities/Public Works:</u>	<i>Rufener</i>	<i>Stimpert</i>	
<u>Public Safety:</u>	<i>Rufener</i>	<i>Axiotis</i>	

Council Representatives to Community Commissions and Boards

<u>EASTGATE, Regional Council of Governments:</u>	<i>Hanson</i>	<i>Stimpert</i>	
	(Per Eastgate - The Mayor is the designated representative)		
<u>Tax Review Board and Enterprise Zone:</u>	<i>Axiotis</i>	<i>Benetis</i>	
<u>Utility Appeals Board:</u>	<i>Benetis</i>	<i>Rufener</i>	<i>Wentworth</i>
	The 3rd seat is always a community member The 4th seat is the Finance Director.		
<u>Local Board of Tax Review:</u>	<i>Stimpert</i>	<i>Benetis</i>	
<u>Economic Development:</u>	<i>Rufener</i>	<i>Axiotis</i>	
	City Manager, Mayor, and Finance Director also serve.		
<u>Police Services Committee:</u>	<i>Benetis</i>	<i>Stimpert</i>	
	<i>Lyden</i>	<i>Wentworth</i>	<i>Talanca</i>
	2 members of Council and 3 residents		



NEWTON FALLS CITY COUNCIL
REGULAR MEETING MINUTES
 Monday, January 6, 2025; 7:00 PM
 COUNCIL CHAMBERS
 612 WEST BROAD STREET

CITY COUNCIL MEMBERS	
Ward 1	Patricia Benetis
Ward 2	Brian Axiotis
Ward 3	VACANT
Ward 4	Kevin Rufener
At- Large	Julie Stimpert
Mayor	David Hanson

CITY ADMINISTRATION	
Interim City Manager	Mike Novotny
Law Director	Jeff Limbian
Finance Director	Jamie Vernaccini
Clerk of Council	Michael Acomb

- I. Call to Order**
 Mayor Hanson called the meeting to order at 6:02 pm.
- II. Pledge of Allegiance / Silent Prayer**
- III. Roll Call**
 Mayor Hanson asked Mr. Acomb to call the roll.
 Council Present: Councilperson Axiotis, Councilperson Benetis, Councilperson Rufener, Councilperson Stimpert, Mayor Hanson.
 Council Absent: None.
 Staff Present: Interim City Manager Novotny, Clerk Acomb, Law Director Limbian,
 Staff Absent: Finance Director Vernaccini.
- IV. Changes To Tonight's Agenda**
 Mr. Rufener, as sponsor, asked to have the Motion in New Business removed from agenda. He explained that making a offer of employment for the position of Police Chief is premature given that the advertisement for the position did not have a deadline for applications and applications continue to trickle in. He stated believe that interviews should happen with any applicant that seems worthy and he does not feel ready to take this action while applications continue to be received. Seconded by Ms. Stimpert

 Mr. Rufener made a motion to add a Motion to set a formal of January 17 as deadline for submission of all applications for position of Police Chief with interviews to be held at the next available meeting. Seconded by Ms. Stimpert.
 Mr. Axiotis worried about that proposed timeline being too aggressive. He stated believe that posting only on the website is insufficient and he recommended a longer timeline to allow other posting resources to be used, including the Ohio Municipal League and the Ohio Association of Chiefs of Police. He made a motion to amend the Motion to Add to change the deadline date from January 17 to January 31. No second. Mayor Hanson recommended against a rushed decision. Mr. Acomb stated that the advertisement would be on Indeed by Wednesday. Ms. Stimpert advocated for moving forward.

 Mr. Rufener made a Motion to suspend Council Rules to allow for more discussion. Seconded by Ms. Stimpert.

No discussion.

Roll Call Vote: Mr. Axiotis-yes; Ms. Benetis-yes; Mr. Rufener-yes; Ms. Stimpert-yes. The motion passed 4-0. Council Rules were suspended.

Mr. Novotny cautioned against rushing to a decision and to remember that there must be some negotiating with the Sheriff department that might have an impact on how things play out. The new Sheriff took office today and so he will arrange a meeting with them soon. He stated that the Sheriff is still working for us but stated that hiring a new chief might impact negotiations with the Sheriff and may negatively affect the current mode of operating.

Ms. Stimpert made a Motion to resume Council Rules. Seconded by Mr. Axiotis.

No discussion.

Roll Call Vote: Mr. Axiotis-yes; Ms. Benetis-yes; Mr. Rufener-yes; Ms. Stimpert-yes. The motion passed 4-0. Council Rules were resumed.

Council voted on the Motion to Add a motion to formal set a date of January 17 for submission and all application for position of police chief with interviews at the next available meeting.

No discussion.

Roll Call Vote: Mr. Axiotis-yes; Ms. Benetis-yes; Mr. Rufener-yes; Ms. Stimpert-yes. The motion passed 4-0.

V. Special Presentations by Staff Members or Invited Consultants

None.

VI. Public Comments (Agenda Items Only)

None.

VII. Reports

- a. Mayor – The owner of the Carroll Theater asked if anyone has any old pictures of this venue that first opened in the 1920's. He gave a brief history of the venue and asked those who can help to contact him.
- b. Council Members
 - i. Ward 1 – Paul King has resigned from the Planning and Zoning Commission after 17 years of service. He expressed sincere thanks to Paul for his service. He urged interested people to contact the Clerk. He gave kudos to the snowplows for working all weekend. They did a great job.
 - ii. Ward 2 – Thank you to the snowplows.
 - iii. Ward 4 – No report.
 - iv. At-Large – The next Fire Board Meeting is January 21 at 6:00 pm. They will hold the Organizational Meeting with the Regular Meeting to immediately follow.
- c. Law Director – No report.
- d. City Manager - He spoke from a prepared statement (Enclosed).

VIII. Approval of Previous Minutes

Mayor Hanson called for a motion to approve the Regular Meeting Minutes December 18, 2024. Moved by Ms. Stimpert. Seconded by Ms. Axiotis.

No discussion.

Roll Call Vote: Mr. Axiotis-yes; Ms. Benetis-yes; Mr. Rufener-yes; Ms. Stimpert-yes. The motion passed 4-0. The minutes were approved.

IX. Public Hearings

ORDINANCE 2024-52

Sponsors: Councilpersons Axiotis, Rufener
Regular Meeting MINUTES, January 6, 2025 | Page 2 of 4

AN ORDINANCE AUTHORIZING CERTAIN AMENDMENTS TO THE APPROPRIATIONS FOR THE FISCAL YEAR ENDING DECEMBER 31, 2024 AND AUTHORIZING THE FINANCE DIRECTOR TO AMEND AND FILE A CERTIFICATE OF RESOURCES WITH THE COUNTY AUDITOR

None.

X. Unfinished Business

ORDINANCE 2024-52

Sponsors: Councilpersons Axiotis, Rufener

AN ORDINANCE AUTHORIZING CERTAIN AMENDMENTS TO THE APPROPRIATIONS FOR THE FISCAL YEAR ENDING DECEMBER 31, 2024 AND AUTHORIZING THE FINANCE DIRECTOR TO AMEND AND FILE A CERTIFICATE OF RESOURCES WITH THE COUNTY AUDITOR

Mayor Hanson read the ordinance by title only and asked for a motion to adopt the ordinance. Moved by Mr. Axiotis. Seconded by Ms. Benetis.

No discussion.

Roll Call Vote: Mr. Axiotis-yes; Ms. Benetis-yes; Mr. Rufener-yes; Ms. Stimpert-yes. The motion passed 4-0. Final Reading.

XI. New Business

MOTION

Motion to add a motion to set a formal date of January 17 for submission of all applications for the position of police chief with interviews to be held at the next available regular meeting.

Mr. Acomb read the Motion and Mayor Hanson called for a motion to pass the Motion. Moved by Mr. Rufener. Seconded by Ms. Stimpert.

Mr. Rufener stated that he is open to a date change. He will not object, but the process needs to proceed with clarity. He also asked for clarity regarding the voting thresholds with a vacant seat. It was clarified that new voting thresholds only apply to ordinances and not motions.

Roll Call Vote: Mr. Axiotis-no; Ms. Benetis-yes; Mr. Rufener-yes; Ms. Stimpert-yes. The motion passed 3-1.

XII. Public Comments

None.

XIII. Closing Remarks

- a. Mayor – He thanked the street department for their impressive work.
- b. Council Members
 - i. Ward 1 – No remarks.
 - ii. Ward 2 – He reiterated his thank you to the Street Department. The Planning and Zoning Commission will meet tomorrow. He encouraged anyone interested and qualified for the Ward 3 vacancy on Council to contact the Clerk. He thanked Paul King again and urged members of the community to consider serving on the Planning and Zoning Commission.
 - iii. Ward 4 – No remarks.
 - iv. At-Large - No remarks.
- c. Law Director - No remarks.
- d. City Manager - No remarks.

XIV. Motion to Recess into Executive Session (If Necessary)

No motion was made.

XV. Adjournment

Mayor Hanson called for a motion to adjourn the meeting. Moved by Ms. Benetis.

Seconded by Ms. Stimpert.

No discussion.

Roll Call Vote: Mr. Axiotis-yes; Ms. Benetis-yes; Mr. Rufener-yes; Ms. Stimpert-yes. The motion passed 4-0. The meeting was adjourned at 7:53 pm.

APPROVED:

David Hanson, Mayor

ATTEST:

Michael Acomb, Clerk of Council

DRAFT

VILLAGE OF NEWTON FALLS, OHIO
ORDINANCE NO.: 2025-01
SPONSOR: Councilpersons Axiotis, Rufener

AN ORDINANCE AUTHORIZING THE INTERIM CITY MANAGER TO ENTER INTO AN AGREEMENT TO PURCHASE AND INSTALL A REPLACEMENT RAW WATER PUMP FROM HYDROFLO PUMPS AND NATIONAL PUMP & PROCESS INC. FOR THE NEWTON FALLS WATER PLANT

WHEREAS, the condition of the existing raw water pump at the Water Plant is poor and prevents the Water Plant from operating properly; and

WHEREAS, the Water Department Superintendent and Interim City Manager investigated and received options for the purchase and installation services of a replacement pump, as well as the removal and disposal services for the existing pump; and

WHEREAS, pursuant to Ohio Revised Code Section 9.17, formal advertisement and bidding are not required as the purchase is less than \$75,000; and

WHEREAS, Village Council desires to accept the quotation (Exhibit A) from Hydroflo Pumps and National Pump & Process Inc. 180 Treat Road, Aurora, OH 44202., for the purchase and installation services of a replacement pump, as well as the removal and disposal services for the existing pump, as it was determined by the Interim City Manager to be the most cost-effective corrective measure and the lowest and best price for the project; and

WHEREAS, adequate funds for such a request are available for use in 2025.

NOW, THEREFORE, the Council of the Village of Newton Falls, State of Ohio, hereby ordains:

SECTION 1. That Council hereby and herein authorizes the Interim City Manager to enter into an agreement with Hydroflo Pumps and National Pump & Process Inc. 180 Treat Road, Aurora, OH 44202, to purchase a replacement raw water pump and to contract with said company for installation services and removal/disposal services of the existing pump for \$50,324.00 as set forth in the attached quotation (Exhibit A).

SECTION 2. That all formal action of this Council concerning and relating to the adoption of this Ordinance was taken in an open meeting of this Council, and all deliberations of this Council or any of its committees that resulted in such formal action were taken in meetings open to the public and/or in compliance with all legal requirements, including Section 121.22 of the Ohio Revised Code.

SECTION 3. That this Ordinance shall be effective as of the earliest date permitted by law.

ORDINANCE NO.: 2025-01
PAGE 2

PASSED IN COUNCIL THIS _____ DAY OF _____, 2025.

David Hanson, Mayor

Attest:

Michael Acomb, Clerk of Council

Approved as to Legal Form.

Jeff Limbian, Law Director



QUOTATION

Date: November 4, 2024

ZERO LEAD PUMPS®

Quote #: 2411032-C

Project: RAW WATER

Job #: REPLACE PUMP

Page #: 1 of 11

Attention: CODY ZELENY

E-Mail: 330-719-2175

Phone: 330-719-2175

Fax: Newton Falls WTP

Company: 175 W River Road
Address: Newton Falls, OH 44444
City, State:



NATIONAL PUMP & PROCESS INC.



180 Treat Road, Aurora, Ohio 44202
 330-562-0220 office 330-562-8783 fax
 www.nationalpump.com

From: Matt Glova

E-Mail: Matt@nationalpump.com

Phone: 216-316-3097 Mobile

Fax: 180 Treat Rd, Aurora, OH 44202

Address:
City, State:

Qty	Part #	Description	Unit Price	Total
		* DESIGN: 1250 USGPM @ 175' TDH, 1770 RPM, *		
		80.8% Efficient, 68.3 BHP, 198.08 Inch TPL (+/- 1.5")		
1	12LC3C-57714-w_B3	12LC - 3 Stage W/L VERTICAL TURBINE PUMP ASSEMBLY *** Fully Assembled Vertical Turbine *** DRIVER ASSEMBLY SECTION – Re Use Existing Motor DISCHARGE HEAD ASSEMBLY SECTION • 1.25" x 6" x 416SS Head Shaft Assembly w/ 10TPI-LH Bronze Adjusting Nut and Key • Hi Ring Base Kit: • F-Style Fabricated Steel Head with 8" 150# RF Discharge Flange for BD with 25" W x 25" L x 1.38" Thick Integral Base – Shaft Guard: Special Fabrication – 1.25" Cast Iron Packing Box Assembly w/ B10 C932 Bronze Bearing, John Crane #1345 Packing, Bronze Lantern Ring and SS Packing Gland • Base Plate: Special Steel 25" W x 25" L x 1" Thick COLUMN ASSEMBLY SECTION • 2 Piece Column Assembly: ~ 139.75" of 8" x .322" Wall x 9' 11-1/4" Steel Water Lubricated Column with Threaded Couplings • 1 Pc(s): 8" x 2" x .75" 201SS Spiders w/ Rubber Inserts • 2 Piece Lineshaft Assembly: 1.25" -WL 12 TPI x 120" x 416SS w/ 316SS Couplings – Top Shaft: 1.25" -WL 12 TPI x 416SS w/ 316SS Coupling – Lineshaft: 1.25" -WL 12 TPI x 416SS w/ 316SS Couplings BOWL ASSEMBLY SECTION • 12LC - 3 Stage Product Lubricated Bowl Assembly w/ 18-8 SS Fasteners including: – 8" Butt Thread, Ductile Iron Discharge Case with B10 C932 Bronze Bearing – Ductile Iron Bowls – B10 C932 Bronze Bowl Bearings – 201SS Impellers with 316SS Collets – 416SS Bowl Shaft: 8.00" Water Lube Projection x 1.25" DIA - WL 12 TPI – 8" NPT, Ductile Iron Suction Case with B10 C932 Bronze Bearing • 304SS Bolt-On Basket Strainer • Crating and Painting • Min. Submergence from Bottom of Suction for Vortex Suppression = 33" (In.). **This does not include NPSHr requirements. NPSHr at Duty Point = 17.1' (Ft.). GENERAL NOTES: 1. QUOTED TO CUSTOMER REQUEST. Terms: Net 30, Freight: F.O.B. Shipping Point: Pre Paid and Add. Estimated Total Assembly Weight As Above: 2252 Lbs.	\$ 36,434.00	\$ 36,434.00

Standard time to have ready to ship is ~ 14 to 16 weeks A.R.O. based on current inventory and factory loads.
 * Please advise of your delivery needs and we will do our best to meet them.

Shipment time is an approximation based on current inventory and factory production schedules. Quotation is valid for 30 days from Quote date. **All certified performance tests will be administered according to the ANSI/HI 14.6 standards set by the Hydraulic Institute. Test results will be measured according to the grade 2B tolerances for pumps rated with a shaft power of 134HP or less and grade 1B for those over 134HP. Pumps meeting these tolerances will be considered passing the tests. It is recommended that the customer refer to the Hydraulic Institute Standards to understand performance guidelines and hydraulic design.

Company: National Pump & Process, Inc.

Name:

Date: 10/30/2024



Pump:

Size: 12LC (3 stage)
 Type: Vertical
 Synch Speed: 1800 rpm
 Curve: 12LC
 Specific Speeds:
 Dimensions:
 Vertical Turbine:
 Speed: 1770 rpm
 Dia: 7.965 in
 Impeller: 12LC SS ENCL.
 Ns: ---
 Nss: ---
 Suction: 8 in
 Discharge: 10 in
 Bowl Size: 11.8 in
 Max Lateral: 1 in
 Thrust K Factor: 7.5 lbf/ft

Search Criteria:

Flow: 1250 US gpm Head: 175 ft

Fluid:

Water
 Density: 62.32 lb/ft³
 Viscosity: 0.9946 cP
 NPSHa: ---
 Temperature: 68 °F
 Vapor Pressure: 0.3391 psi a
 Atm Pressure: 14.7 psi a

Motor:

Standard: NEMA
 Enclosure: WP1
 Sizing Criteria: Max Power on Design Curve
 Size: 75 hp
 Speed: 1800 rpm
 Frame: 365T

Pump Limits:

Temperature: 140 °F
 Pressure: 350 psi g
 Sphere Size: 0.73 in
 Power: 350 hp
 Eye Area: ---

---- Duty Point ----	
Flow:	1250 US gpm
Head:	175 ft
Eff:	80.8%
Power:	68.3 hp
NPSHr:	17.1 ft
---- Design Curve ----	
Shutoff Head:	235 ft
Shutoff dP:	102 psi
Min Flow:	205 US gpm
BEP:	82.2% @ 1026 US gpm
NOL Power:	74.8 hp @ 1598 US gpm
-- Max Curve --	
Max Power:	92.7 hp @ 1738 US gpm

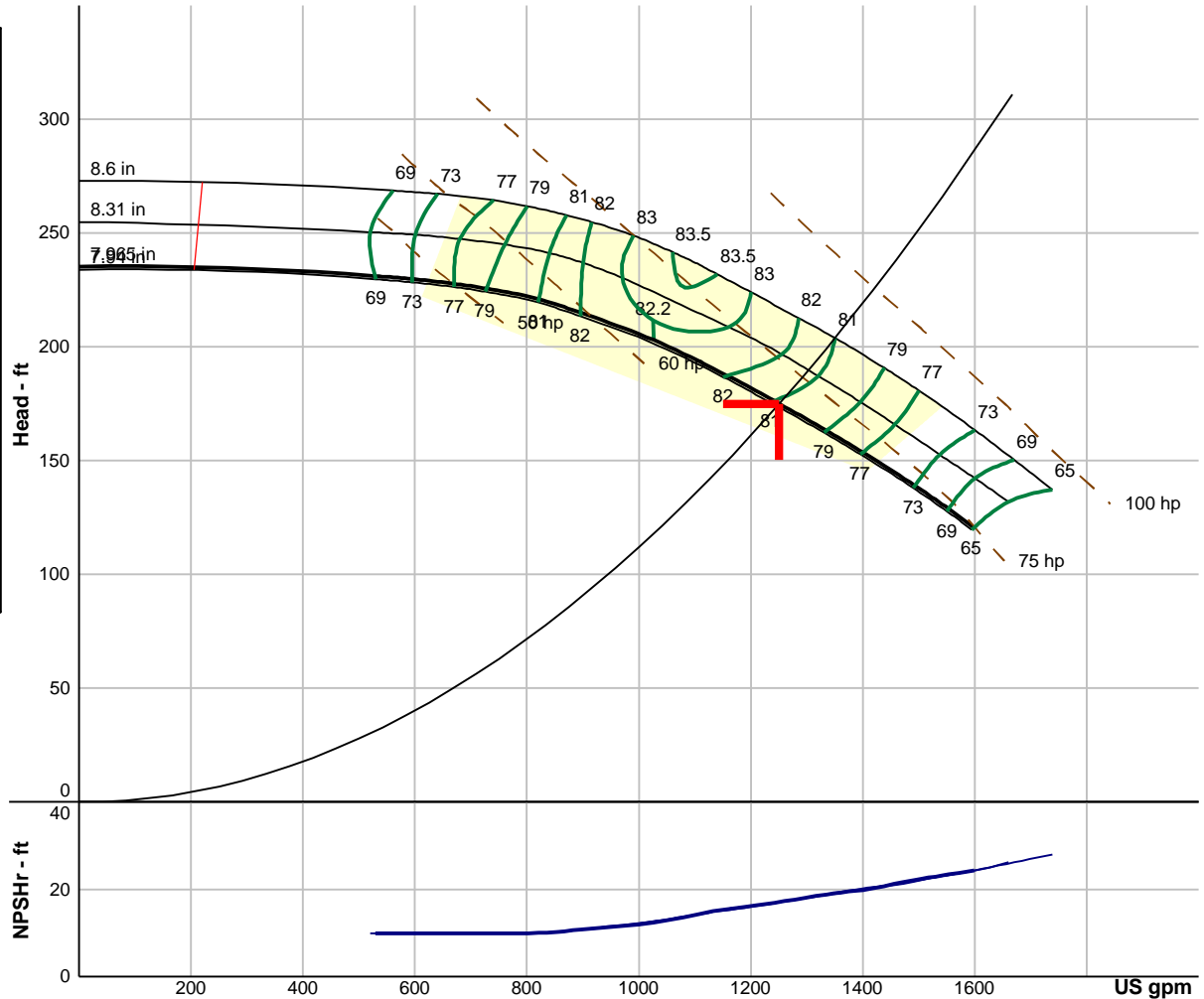

Performance Evaluation:

Flow US gpm	Speed rpm	Head ft	Efficiency %	Power hp	NPSHr ft
1500	1770	138	72.5	71.9	22.3
1250	1770	175	80.8	68.3	17.1
1000	1770	205	82.1	63	12.1
750	1770	225	79.5	53.4	10
500	1770	231	67.3	43.6	10

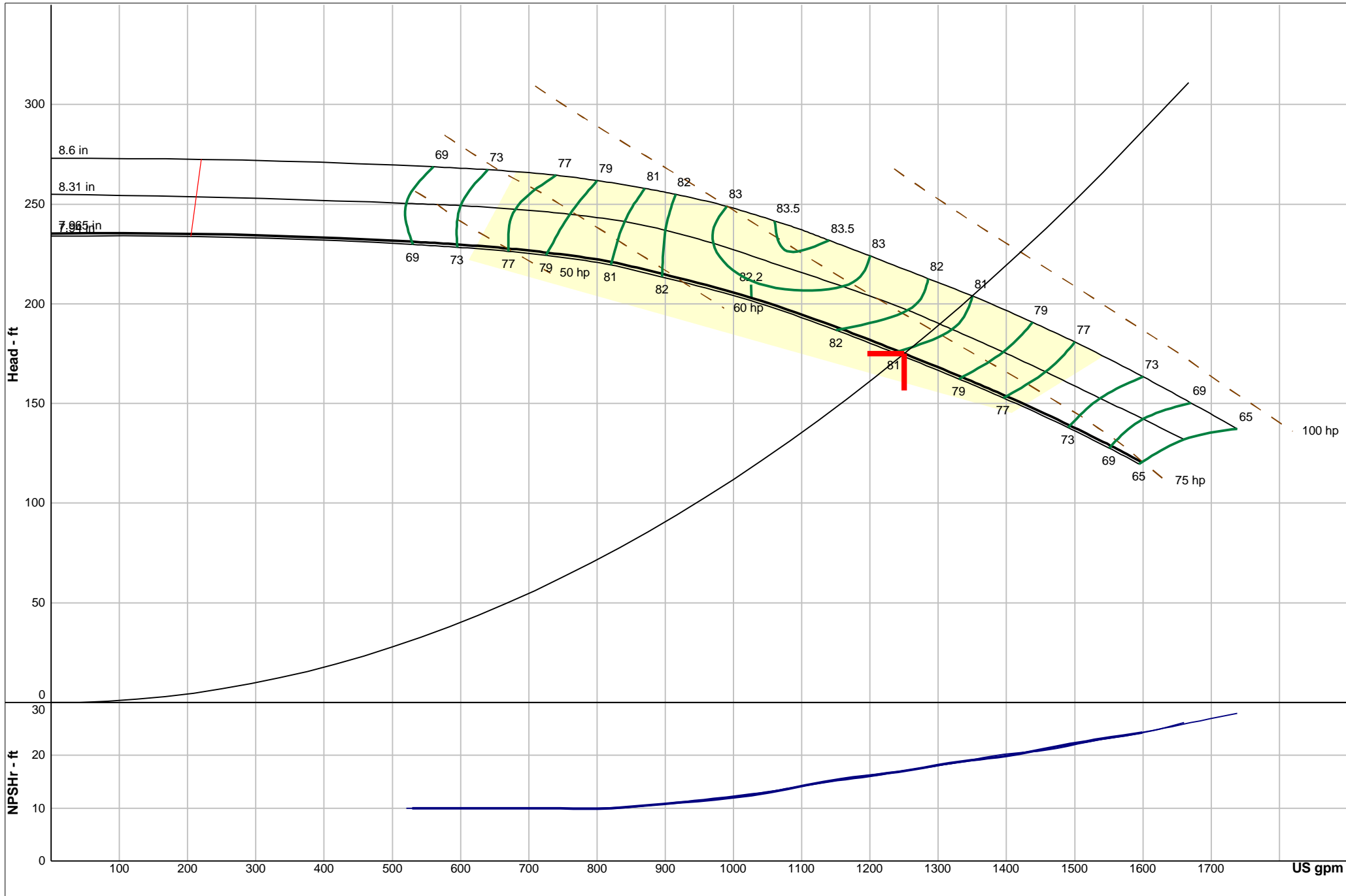

Company: National Pump & Process, Inc.
 Name:
 10/30/2024

Hydroflo Pumps USA, Inc.
 Catalog: Hydroflo VS Pumps.60, Vers 18.3
 Vertical - 1800 rpm
 Design Point: 1250 US gpm, 175 ft

Size: 12LC (3 stage)
 Speed: 1770 rpm
 Dia: 7.965 in
 Curve: 12LC
 Impeller: 12LC SS ENCL.



CRITICAL SPEED ANALYSIS

CUSTOMER: National Pump & Process, Inc.

CONFIGURATION: C-57714-w

<u>CALCULATION INFORMATION</u>		<u>PUMP ASSEMBLY</u>		<u>LINESHAFT ASSEMBLY</u>	
Impeller Weight:	16.00 lbs	GPM:	1250	Lineshaft Diameter:	1.25"
K-Factor:	7.5 lbs/ft	TDH:	175	Lineshaft Material:	416SS
Total Thrust Load:	1451 lbs	Nominal Speed:	1770	Lineshaft Weight:	0.3477 lbs/in
Moment of Inertia:	0.1198 in ⁴	Pump Model:	12LC	Bearing Material:	RUBBER
Modulus of Elasticity:	29000000 lbs/in ²	Stages:	3	Bearing Spacing:	120.00"

CALCULATION METHODOLOGY

$$N_c = \frac{30n}{l} \sqrt{\frac{g}{w}} \sqrt{EI \left(\frac{n\pi}{l} \right)^2 + T}$$

N = shaft RPM

w = unit weight of shafting

n = critical speed number

E = modulus of elasticity

l = length between supports

I = moment of inertia

g = acceleration due to gravity

T = total thrust load

FINAL CALCULATIONS

<u>FIRST CRITICAL</u>	<u>SECOND CRITICAL</u>	<u>THIRD CRITICAL</u>	<u>*UNDER / OVER</u>
516 RPM	1746 RPM	3781 RPM	1416 RPM 2124 RPM

* The Critical Speeds for the bearing system should be outside the UNDER / OVER RPM's listed above.

NOTICE

The above equation is based on "The Calculation of Natural Frequency Vibration and Critical Speeds of Shafts Carrying a Direct Tensile Load", by E.L. Thearle, with modifications to fit all basic vertical turbine pumps. The calculations contained herein are only based on the above information and do not account for the pump unit once installed. Critical Speeds and Critical Frequencies are ultimately based on the complete unit mounted in place. The foundation, piping, mounting surface, type of fastening and many other factors directly affect the final Critical Speeds and Critical Frequencies associated with the final operating pump unit in its final position. Per the Hydraulic Institute website: "in a field installation, the vibrating structure comprises, in addition to the pump, the foundation, the mounting, the piping and its supports, and may include the driver and flexible shafting. The natural frequency of the vibrating structure is determined by the stiffness of the total structure and by its equivalent mass. It may therefore differ significantly from the natural frequency of the pump alone."

**TPL and Total Column Lengths +/- 1.5"
All Dimensions In Inches

PROJECT SPECIFICATIONS

Date: 10/30/2024
 Job:
 Config #: C-57714-w
 GPM: 1250
 Head FT: 175
 Pump Model: 12LC - 3 Stage
 Imp. Type: 12LC SS ENCL.
 Pump Materials: Ductile Iron / 201SS
 Bowl Bearings: B10 C932 Bronze
 Bowl Shaft: 1.6875" 416SS
 Strainer Type: 304SS Bolt-On Basket
 Column: 8" x .322" wall
 Lineshaft: 1.25" 416SS
 Lineshaft Brgs: Rubber
 Discharge Head: Fabricated Steel Head
 Discharge Flange: 8" 150# RF Discharge Flange
 Seal Type: John Crane #1345 Packing
 Head Shaft: 1.25" 416SS
 Foundation Plate: Steel

Minimum Submergence

Minimum Submergence from bottom of suction for vortex suppression: 33". *This does NOT include NPSHr needs.

DRIVER INFORMATION

Mfr: US
 Enclosure: VHS-TEFC
 HP: 75
 RPM: 1800
 Phase/Volt:
 Frame:
 Efficiency: N/A
 NRR or SRC: NRR

Column Note

The column dimensions, on this side, do not include the bearing spiders.

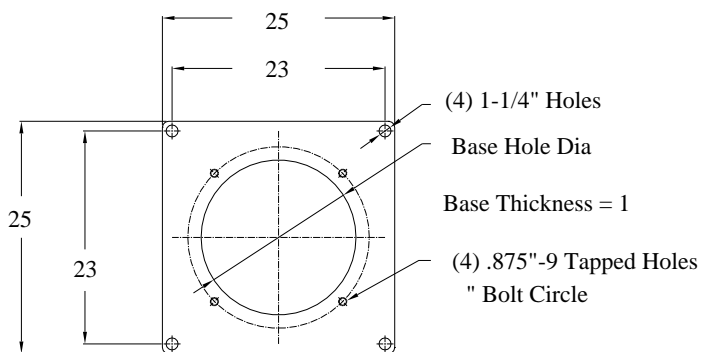

FOUNDATION PLATE

Estimated Shipping Weight: 2252 Lbs.

NOT FOR CONSTRUCTION

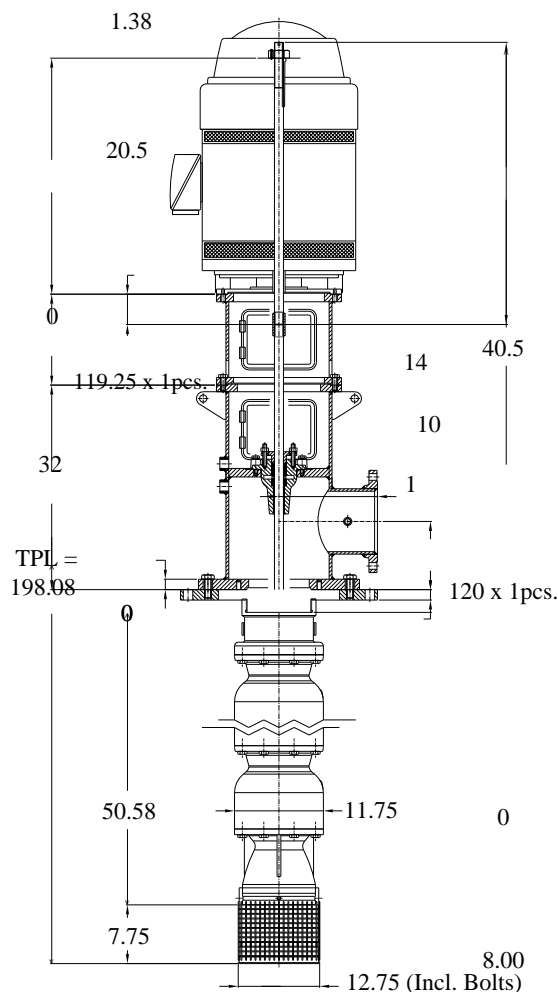

NOTICE

This drawing is the confidential property of Hydroflo Pumps USA, Inc., a Taco Group Company and is furnished for your Information only and must not be made public or copied and must be returned on demand. Manufacture of parts per this drawing is expressly forbidden except by written authorization from Hydroflo Pumps USA, Inc., a Taco Group Company. All rights of design and invention are reserved and patents pending.

REV	DATE	REVISION	CH
REFERENCE		HYDROFLO PUMPS INC. WORK ORDER NO.	
PUMP S.N.		NO. REQD:	Qty
MATERIAL: NOTED			



HYDROFLO PUMPS USA, INC.
 7118 LOBLOLLY PINE BLVD.
 FAIRVIEW, TN 37062
 PHONE: 615.799.9662
 FAX: 615.799.5654

**National Pump & Process, Inc.
 12LC - 3 Stage Product Lubricated
 Vertical Turbine Pump System**

CUSTOMER P.O. NO.	General Arrangement Design Specifications		
DR BY: Config	DATE: 10/30/2024	DWG. NO.	SHT.
CK BY:	DATE:		REV.

THIS DRAWING MUST BE SIGNED
AND RETURNED WITH THE ORDER

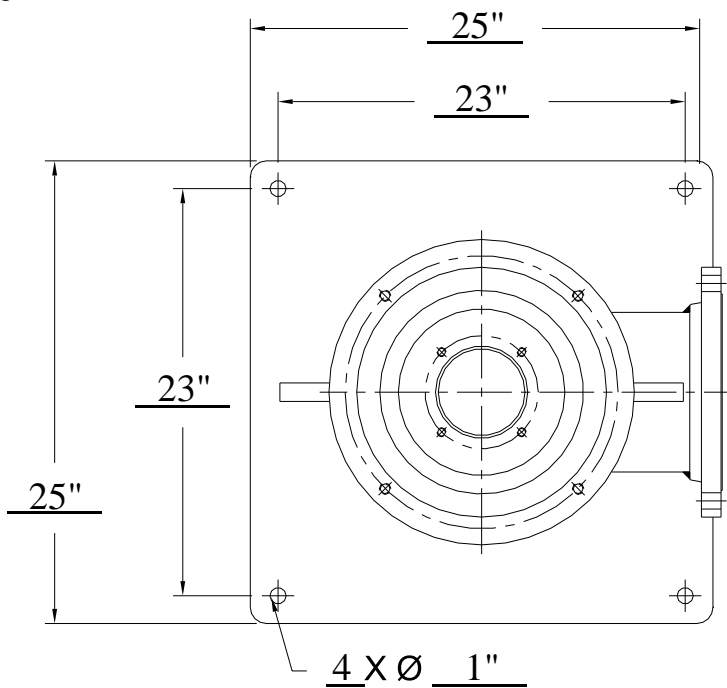

SQUARE BASE

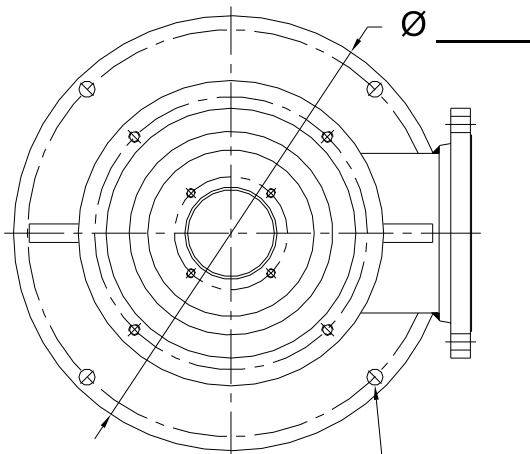

___ X Ø ___ HOLES THRU
EQ. SPACED ON Ø ___ B.C.

~~**ROUND BASE**~~

8 " HF F-TYPE FAB. HEAD

SPECIAL NOTES:

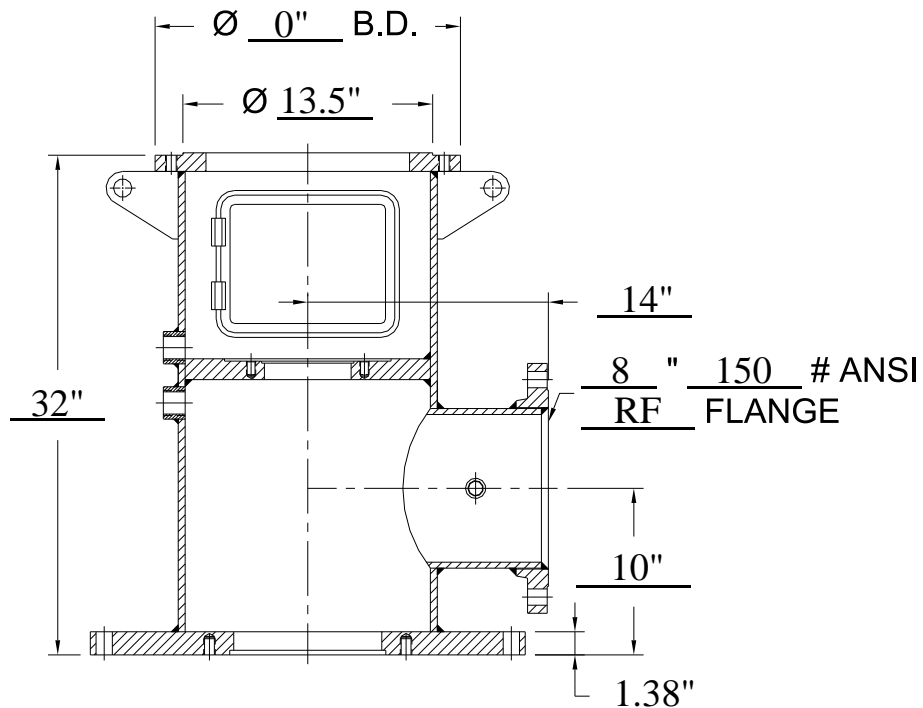

SIDE VIEW

APPROVED BY:

DATE: / /

NOTICE

THIS DRAWING IS THE CONFIDENTIAL PROPERTY OF HYDROFLO PUMPS USA INC. AND IS FURNISHED FOR YOUR INFORMATION ONLY AND MUST NOT BE MADE PUBLIC OR COPIED AND MUST BE RETURNED ON DEMAND. MANUFACTURE OF PARTS PER THIS DRAWING IS EXPRESSLY FORBIDDEN EXCEPT BY WRITTEN AUTHORIZATION FROM HYDROFLO PUMPS USA INC. ALL RIGHTS OF DESIGN AND INVENTION ARE RESERVED AND PATENTS PENDING.

REV	DATE	REVISION	CH

HydrofloPumps 7118 LOBLOLLY PINE BLVD.
Fluid Solutions FAIRVIEW, TN 37062
A Taco Group Company PHONE: 615-799-9662
FAX: 615-799-5654

National Pump & Process, Inc.
12LC - 3 Stage Water Lube Pump
F-Style Fabricated Head Worksheet

Dimensions In Inches Unless Otherwise Noted	HYDROFLO PUMPS INC.	CONFIGURATION No.: C-57714-w	HF F-Type Fabricated Head Measurements Worksheet
Material:		CUSTOMER P.O.:	
Work Sheet Date: 09/02/2015		DR BY: DATE:	Form NO. SHT. Rev
		CK BY: -- DATE: --/--/--	HFFFDH01R0 1 of 1 0

ItemNo.	Qty.	Description	Material Grade
1	1	Bowl Shaft	416 Stainless Steel
5	1	Bearing - Oil Tube Adapter (Half Bearing)	BRZ C932
9	2	Pipe Plug - Discharge	A-197 Black Iron
10	1	Bearing - Discharge Case	C93200 Bronze
12	1	Discharge Case	A-536 GR. 65-45-12
14	8	Bolt - Discharge Case	18-8 Stainless Steel
16	3	Bowl	A-536 GR. 65-45-12
18	3	Bearing - Bowl	C93200 Bronze
19	3	Impeller Collet	316 Stainless Steel
20	3	Impeller	201 Stainless Steel
23	16	Bolt - Bowl	18-8 Stainless Steel
24	8	Bolt - Suction	18-8 Stainless Steel
25	1	Suction - Threaded	A-536 GR. 65-45-12
27	1	Sand Collar	201 Stainless Steel
28	1	Bearing - Suction	C93200 Bronze
29	1	Pipe Plug - Suction	A-197 Black Iron
31	1	Strainer - Bolt-On Basket	304 Stainless Steel

ZOOM FOR DETAIL

NOT TO SCALE

PROJECT SPECIFICATIONS

Date: 10/30/2024
 Job:
 Config #: C-57714-w
 GPM: 1250
 Head FT: 175
 Pump Model: 12LC - 3 Stage
 Imp. Type: 12LC SS ENCL.
 Pump Materials: Ductile Iron / 201SS
 Bowl Shaft Dia: 1.6875

DRIVER INFORMATION

Mfr: US
 Enclosure: VHS-TEFC
 HP: 75
 RPM: 1800
 Phase/Volt:
 Frame:
 Efficiency: N/A
 NRR or SRC: NRR

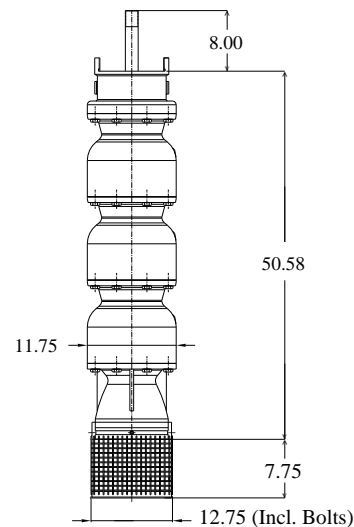
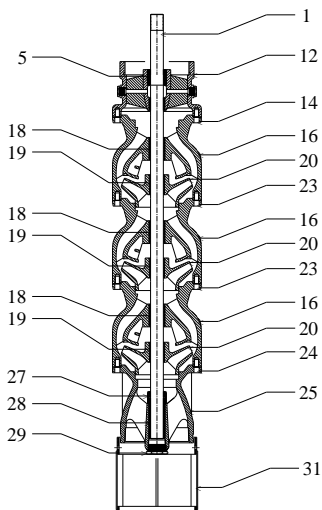

Estimated Bowl Assy
 Weight: 514 Lbs.

NOT FOR CONSTRUCTION

NOTICE

This drawing is the confidential property of Hydroflo Pumps USA, Inc., a Taco Group Company and is furnished for your Information only and must not be made public or copied and must be returned on demand. Manufacture of parts per this drawing is expressly forbidden except by written authorization from Hydroflo Pumps USA, Inc., a Taco Group Company. All rights of design and invention are reserved and patents pending.



HYDROFLO PUMPS USA, INC.
 7118 LOBLOLLY PINE BLVD.
 FAIRVIEW, TN 37062
 PHONE: 615.799.9662
 FAX: 615.799.5654

National Pump & Process, Inc.
12LC - 3 Stage Water Lube
Vertical Turbine Pump System

REV	DATE	REVISION	CH

REFERENCE	HYDROFLO PUMPS INC. WORK ORDER NO.	CUSTOMER P.O. NO.	General Arrangement Design Specifications		
PUMP S.N.	NO. REQD: Qty	DR BY: Config DATE: 10/30/2024	DWG. NO.	SHT.	REV.
MATERIAL: NOTED		CK BY: DATE:			

ItemNo.	Qty.	Description	Material Grade
1	1	Bowl Shaft	416 Stainless Steel
5	1	Bearing - Oil Tube Adapter (Half Bearing)	BRZ C932
9	2	Pipe Plug - Discharge	A-197 Black Iron
10	1	Bearing - Discharge Case	C93200 Bronze
12	1	Discharge Case	A-536 GR. 65-45-12
14	8	Bolt - Discharge Case	18-8 Stainless Steel
16	3	Bowl	A-536 GR. 65-45-12
18	3	Bearing - Bowl	C93200 Bronze
19	3	Impeller Collet	316 Stainless Steel
20	3	Impeller	201 Stainless Steel
23	16	Bolt - Bowl	18-8 Stainless Steel
24	8	Bolt - Suction	18-8 Stainless Steel
25	1	Suction - Threaded	A-536 GR. 65-45-12
27	1	Sand Collar	201 Stainless Steel
28	1	Bearing - Suction	C93200 Bronze
29	1	Pipe Plug - Suction	A-197 Black Iron
31	1	Strainer - Bolt-On Basket	304 Stainless Steel

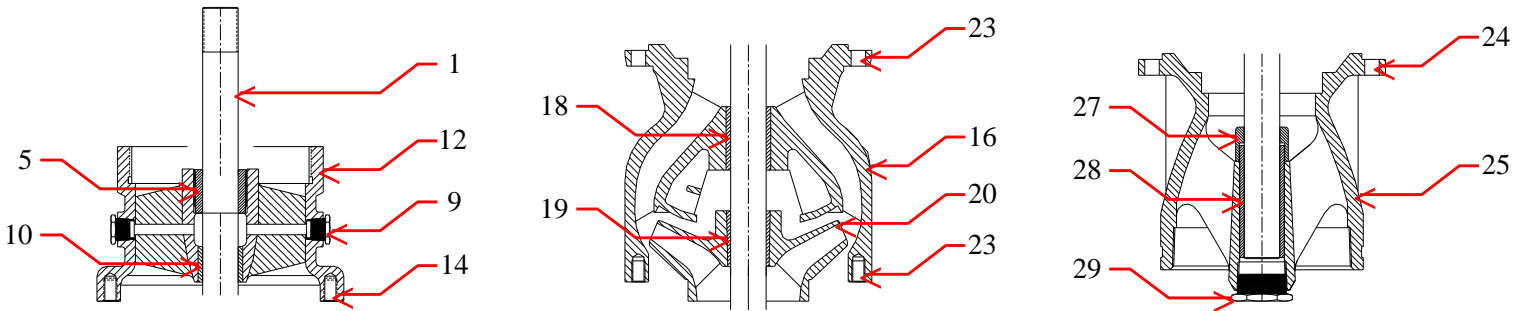

Pump Model: 12LC - 3 Stage

NOT FOR CONSTRUCTION

Config #: C-57714-w

NOTICE

This drawing is the confidential property of Hydroflo Pumps USA, Inc., a Taco Group Company and is furnished for your information only and must not be made public or copied and must be returned on demand. Manufacture of parts per this drawing is expressly forbidden except by written authorization from Hydroflo Pumps USA, Inc., a Taco Group Company. All rights of design and invention are reserved and patents pending.



HYDROFLO PUMPS USA, INC.
 7118 LOBLOLLY PINE BLVD.
 FAIRVIEW, TN 37062
 PHONE: 615.799.9662
 FAX: 615.799.5654

National Pump & Process, Inc.
12LC - 3 Stage Water Lube
Vertical Turbine Pump System

REV	DATE	REVISION	CH

REFERENCE	HYDROFLO PUMPS INC. WORK ORDER NO.	CUSTOMER P.O. NO.	General Arrangement Design Specifications		
PUMP S.N.	NO. REQD: Qty	DR BY: Config DATE: 10/30/2024	DWG. NO.	SHT.	REV.
MATERIAL: NOTED		CK BY: DATE:			

 <p>NATIONAL PUMP & PROCESS INC.</p>	<p>National Pump & Process 180 Treat Rd Aurora, OH, 44020 Phone: (330) 562-0220</p>	<p>Quote #: 2411032-B Raw Water Pump Removal and Installation</p>
--	---	---

<p>Cody Zeleny City of Newton Falls WTP 175 W. River Road Newton Falls, OH, 44444</p>	<p>Phone: (330) 872-1808 Mobile: 330-719-2175 Email: Waterplant@ci.newtonfalls.oh.us</p>	<p>Date: 04/11/2024 Rep.: Matt Glova Mobile: (216)-316-3097</p>
---	--	---

Qty	Item #	Name	Price	Total
1	REMOVE	Field Service All labor and material to perform the following. ~Supply field crane support for pump removal ~Disconnect motor and remove from pump head and set aside ~Disconnect pump from discharge line and mounting ~Remove pump and transport to NPP shop for repair	\$6,945.00	\$6,945.00
1	INSTALL	Field Service All labor and material to perform the following ~Transport repaired pump back to raw water pump station ~Supply crane support for pump installation ~Rig and set pump in position ~Connect discharge line ~Set existing motor and make electrical connections ~Set pump operational lift ~Start up and testing	\$6,945.00	\$6,945.00
			Sub Total	\$13,890.00
			Shipping & Handling	
			Taxes	0.000% \$.00
			TOTAL	\$13,890.00



Thank you for your business